

Titus Group
Technical Catalogue
and Manual



Furniture Fittings Systems

2022

Important Information

Technical information

While every effort has been made in the production of this catalogue to ensure the accuracy of information, our products are continually being revised and users should confirm the up to date specification before ordering. Due to constant improvement of products presented in the catalogue, we can make changes at any time and without notice.

Responsibility

It is the responsibility of the user to ensure the fitness of hardware for the intended purpose. We recommend assessment by appropriate testing in the application and by technical enquiry to our representatives.

Intellectual property

Titus Group owns the intellectual property rights in its products worldwide whether as trademarks, patents, intellectual, copyright, designs, illustrations, drawings and the 'know how' contained in their design and production. Titus Group respects the equivalent rights in competitors and all other relevant product design rights. To our knowledge our products do not infringe any intellectual property rights of competitors or other parties. Titus Group takes infringements of its rights seriously and will rigorously defend these rights to the full extent of the law.

*Non-standard articles

All Item numbers in the catalogue marked with * are for non preferred items available on extended delivery times.

Trademarks

Titus and Titusonic are registered trademarks of Titus International Ltd. Lama is a registered trademark of Titus d.o.o. Dekani, WoodWelding is a registered trademark of WW SA.

Contents

1

2

3

4

5

Cabinet Connectors

- System 1
- System 2
- System 3
- System 4
- System 5
- System 6
- System 7
- Cabinet Fittings

1.1

Concealed Hinges

- Information
- T-type hinges
- S-type hinges
- B-type hinges
- Glissando Soft Closing Systems
- PushOpen Solutions
- Accessories

2.1

Tekform Slimline Drawer

- Tekform Slimline Drawer
- Tekform Slimline Tacto

3.1

Soft Closing Systems for Sliding Doors and Drawers

- Slidix Soft Closing Systems
- Titusoft Soft Closing Systems
- Set 200
- Rails

4.1

The Titus Group Profile

5.1

Cabinet Connectors

Cabinet Connectors

Product Guide

Page

System 1

Fittings for rigid assembly systems

a highly cost-effective and rigid assembly system for factory, consumer and home assembly

1.9

System 2

Fittings for face-boring applications

face boring applications that provide a tolerant efficient assembly

1.11

System 3

Fittings for face and edge boring

two component rigid face and edge drilling fastening

1.15

System 4

Fittings for face-boring only

a range of low-cost one-piece fittings for high volume home assembly applications

1.17

System 5

Cams and dowels

a comprehensive range of cam and dowel connecting fittings for all cabinet applications

1.23

Page

System 6

Quickfit-Expando connectors	face boring expanding connectors for all cabinet applications	1.47
-----------------------------	---	------

System 7

Heavy duty cams and dowels	high quality fittings for offices and public furniture	1.59
----------------------------	--	------

Cabinet Fittings

Complementary and structural support fittings	Shelf supports	1.65
	Joining plates	1.68
	Panel brackets and wall connectors	1.69
	Adjustable cabinet legs	1.71
	Drawer front adjuster	1.75

Connectors

Information

Why Choose Titus?

Titus connectors add value to furniture and to furniture manufacturing

Titus connectors improve the quality of furniture and lower the cost of manufacturing and assembly while ensuring a high degree of customer satisfaction.

The most advanced range of connectors available on the market

Precise and efficient product design. **The broadest possible range of drilling tolerances** ensures reliable assembly and consistently strong joints. **'Klix'** locking feature, the engagement of interlocking teeth on cam and dowel, to prevent joint loosening in service or transit.

Expanding function provides degrees of variation in out-of-tolerance drillings ensuring stronger joints and improved quality of furniture.

Twinstart thread for faster and more stable insertion.

Depth stop collar prevents over-insertion.

Firm tightening for greater confidence in use.

Cam locks at 230° assuring smooth tightening action and greater dowel pull-up.

Quickfit for hand dowel insertion.

Quickfit TL5, new generation steel dowel with quickfit expando technology for insertion in Ø5mm dowel holes.

Quickfit TL2, TL4 with the built-in self adjustment feature for higher drilling tolerances.

Quickloc one piece fitting for faster assembly with integrated expanding cam and dowel.

Zinc+steel dowel for optimal strength and performance.

Precise dowel manufacturing high precision of zinc and strength of steel assures 100% dimensional accuracy.

Easy and quick consumer friendly self-assembly of furniture

Self-assembly furniture offers consumers good value and instant availability of products.

With the aim of providing consumer with simpler instructions, fewer parts and an easier assembly process, Titus has significantly reduced and simplified the number of fittings traditionally required in furniture production.

Titus connectors provide consumers with easy assembly and furniture producers with increased productivity:

- reduced number of assembly parts
- easy assembly instructions
- security of packed parts during transit

CAF Quick & Easy

Consumer Assembly Friendliness

Easy and Quick Furniture Assembly

CAF formula

CAF=Consumer Assembly Friendliness

Titus CAF formula provides a comparative measure for customer satisfaction. By using it manufacturers are able to evaluate their products internally or against those of their competitors.

While offering consumers easier and faster assembly, there are obvious advantages also for furniture manufacturers – buying, counting, bagging and stocking of fittings can be greatly reduced.

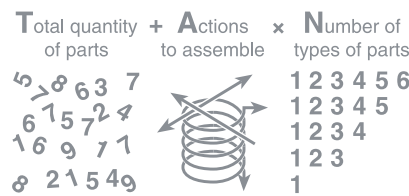

$$(T+A)N = CAF$$

Minimise the numbers in the Titus CAF™ formula to achieve:

- High customer satisfaction
- Improved productivity
- Higher profits

How does it work?

Comparative CAF scores to assemble a hand held demonstrator

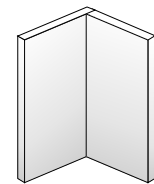

	T	A	N	CAF
Connecting screw (traditional assembly)	4	38	3	126
Cam & dowel with single start thread	6	21	4	108
Cam & dowel with twinstart thread	6	15	4	84
Cam & TL2 dowel (self-assembly)	6	7	4	52
Cam & TL2 dowel (factory pre-inserted)	2	3	2	10
Quickloc	2	3	1	5
Fully assembled demonstrator	1	0	1	1

Cabinet Connectors

CAF Quick & Easy

Consumer Assembly Friendliness

Consumer Assembly Friendliness - CAF principle

- Quick assembly with less parts and less assembly steps
- Simple instructions
- Easy and intuitive assembly

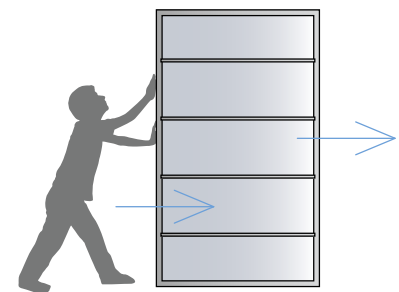
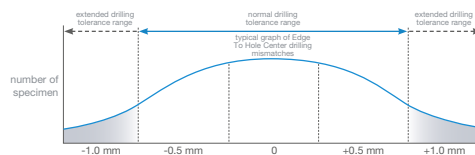

High drilling tolerances

- Optimal cabinet joint even in cases of inaccurate drilling
- In-built self adjustment feature ensures perfectly aligned and precise joints

Strong and reliable joints

- High performance joints
- Great cabinet strength even at repeatable assembly or disassembly
- Enhanced resilience even in more demanding applications in tall wardrobes or office furniture

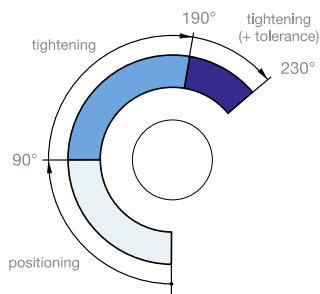

Reliable and comfortable locking

- Smooth and firm tightening at 2 o'clock lock
- Great dowel pull-up for optimal performance
- Strong and reliable joint

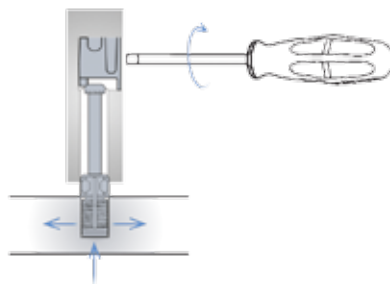

Expando function

- Expanding sleeve on dowels assures high resistance to pull-out
- Firm fixing in the dowel hole

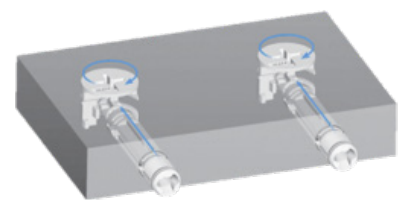

Factory pre-insertion

- With Quickfit TL5 and TL2 dowels
- Perfect for RTA market: easier packing and transportation
- The insertion of cams and dowels can be automated using Lama FastFit machine

System 1

Fittings for Rigid Assembly Systems

System Features

Double locking carcass screw

- Zinc diecast for precision
- Titus Double locking carcass screw makes an almost invisible connection
- Collar under the head to pull panels together
- 2nd 'lower' thread pulls against a 'faster' thread to provide maximum connection force and prevents overdriving of fastener
- Almost invisible in position
- Head can be 'fastcapped' or filled

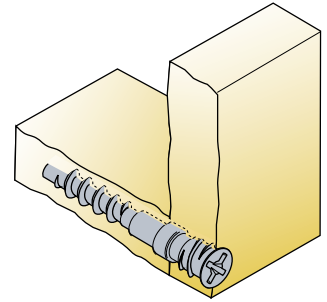

System 1

Fittings for Rigid Assembly Systems

Double Locking Carcase Screw

- High performance from widely spaced primary thread
- Finer secondary thread provides additional holding power and positive stop (no override)
- Increased support for vertical panel is gained from the funnel head with collar at its base
- One-piece fitting

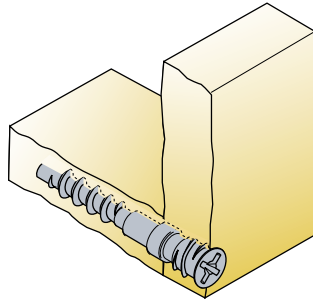

Technical and mounting details

Item number

Zinc

Screw 6x42

00180 →

885

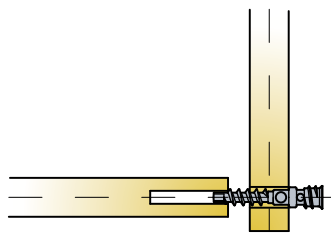
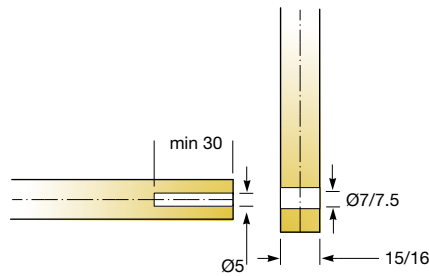
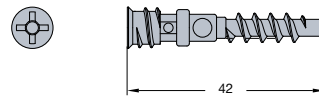

1. Insert screw to shoulder in face board

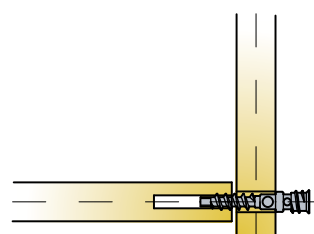

2. Screw into Ø5mm hole

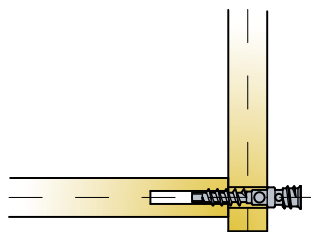

3. Board joint pulled up by collar on screw

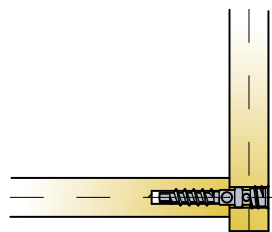

4. Board locked in place by screw

1000 Pcs

Made of zinc

System 2

Fittings for Face-boring Applications

System Features





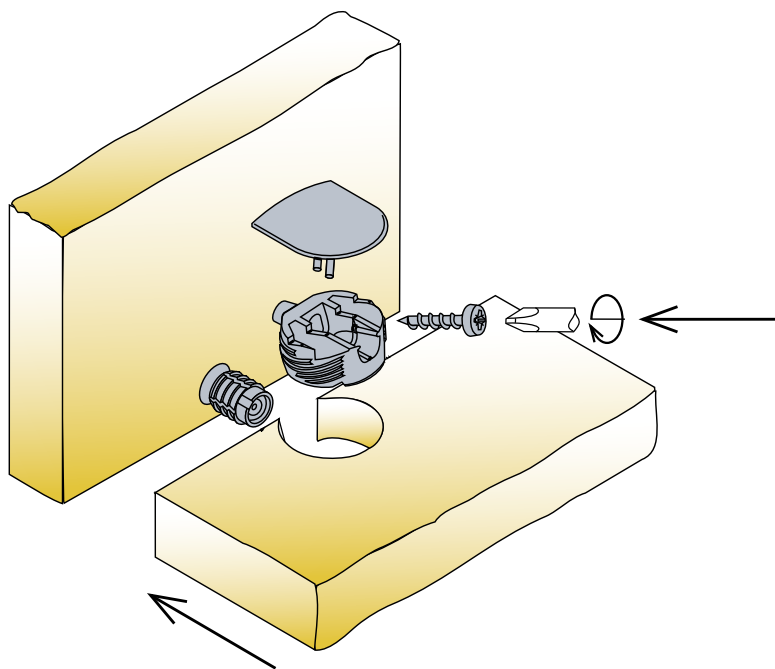

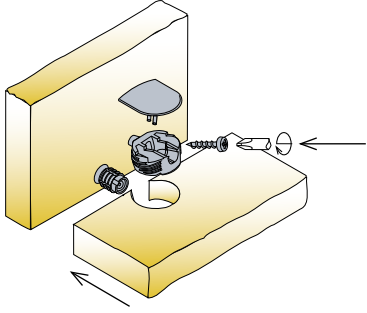

A family of face boring only concealed fittings and rail fasteners with wide tolerances and the enormous clamping power of an angled screw.

- Factory or site component installation
- Wide tolerances
- Face boring only
- Cover caps for concealment
- For kitchen, furniture storage, office and store fixture applications
- Non twist rail fastener versions
- Multi use 'pocket screw' replacement

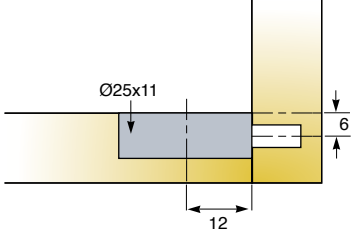

System 2 Fittings for Face-boring Applications Concealed Fittings

- Combination of hi-thread screw and nylon insert allows a high clamping force improving cabinet rigidity
- Unlimited stacking height due to flush housing
- Provides a strong, secure fitting which eliminates the need for edge boring
- +/-1mm tolerance absorbs drilling inaccuracies improving consumer confidence in use

 <p>Technical and mounting details</p>		Item number	 Brown beige	 White	 Zinc plated
<p>Housing (no nose)</p>   <p>2500 Pcs Made of plastic</p>	<p>*02985 →</p> <p><i>*European market only</i></p>	877			
<p>Screw panhead No 8 x 17.6</p>  <p>2500 Pcs Made of plastic</p>	<p>01709 →</p>			883	
<p>Cover cap</p>  <p>7000 Pcs Made of plastic</p>	<p>01732 →</p> <p><i>Other colours on request</i></p>	806	877		
<p>Inserts Made of plastic</p> <p>→ see page 1.62</p> 					

System 2 Fittings for Face-boring Applications

- Range of fixing blocks for multiple applications
- Face drilling only required
- Durable plastic material is flexible providing greater holding power
- Choose screw fastening or hammer insertion

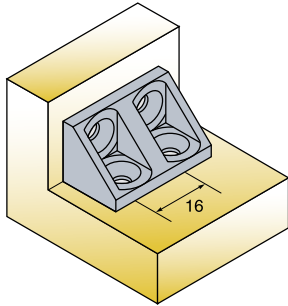

Technical and mounting details

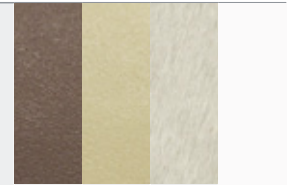

Dark brown

Light brown

Ivory

White

Item number

Rail fastener

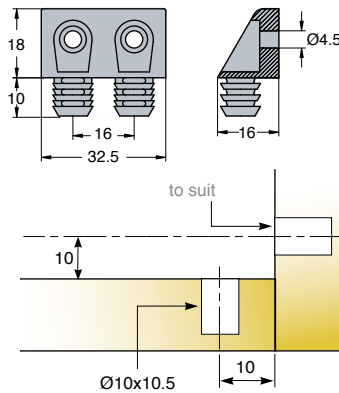

02075 →

831

867

877

2000 Pcs

Made of plastic

Housing (no nose)

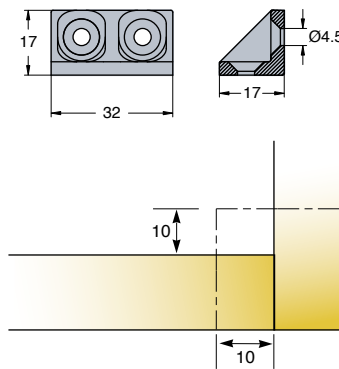

02077 →

875

877

2000 Pcs

Made of plastic

Modesty block

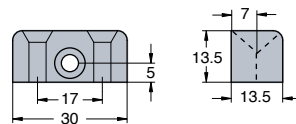

*06073 →

867

877

*European market only

1500 Pcs

Made of plastic

System 3

Fittings for Face and Edge Boring

System Features





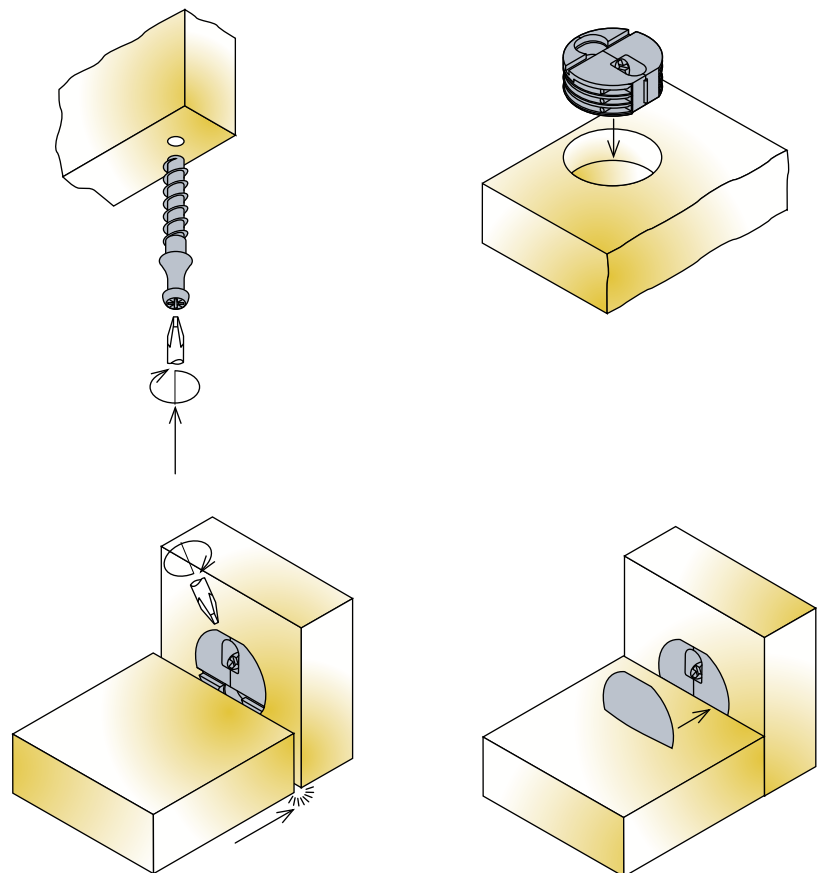





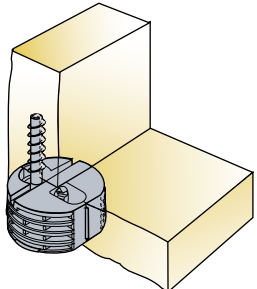

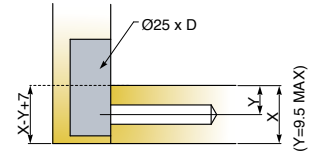
Titus System 3 is a two component rigid face and edge drilled fastening with half turn to fasten. System 3 offers almost full concealment and wide tolerances in use.

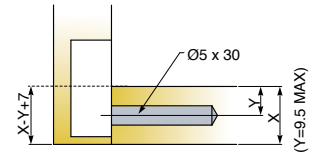
- Automatic or in-factory placement
- Pre-location pin ensures ease of assembly
- Less than one turn of a screwdriver to fasten
- Shelf edge installation of pin means maximum shelf cut size tolerance
- Can be used on 12mm shelf panels
- No loose parts for maximum convenience in RTA
- Drawer front fixing, cabinet construction

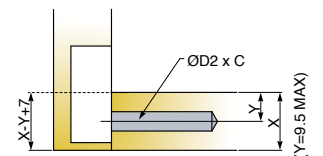

System 3 Fittings for Face and Edge Boring Concealed Housing

- One turn locking system reduces assembly time, both in the factory and home
- Pre-assembly feature for consumer convenience
- Choice of dowels to suit drilling
- Hi-Lo screw feature for faster insertion

Technical and mounting details		C	D	D2						
Technical and mounting details		Drilling length for dowel	Drilling depth for housing	Drilling diameter for dowel thread	Item number	Black	Zinc plated	Dark brown	Yellow passivate	White
										
Housing assembly   X, Y - depends on board thickness		12.5			03118 →	835		831		877
 2500 Pcs Made of plastic or zinc, plastic		<i>Other colours on request</i>								
Screw dowel Ø5   X, Y - depends on board thickness		30		5	03168 →		883			
 1000 Pcs Made of zamak										
Screw dowel Ø3   X, Y - depends on board thickness		11		3.75	03181 →					881
 5000 Pcs (03180)  4000 Pcs (03181)  1000 Pcs (03190) Made of steel		9		3	03180 →					881
		25		3	*03090 →		883			
		<i>*American market only</i>								
Cover cap   15000 Pcs Made of plastic					03150 →	835				877

System 4 Fittings for Face-boring Only

System Features

Cost effective one piece fittings with face boring benefits

- Flush and block components
- Face-boring only
- Good tolerances
- One piece connectors
- Angledrive versions fastening with maximum driving power and flexibility
- Quickloc™ versions need only one turn to tighten for fast assembly
- Foolproof consumer home insertion

Quickloc™ One-piece connector

The integrated housing and dowel make Quickloc™ the most user-friendly and tolerant product available.

- High degree of drilling tolerance
- Push-in design
- Tool-free insertion
- Integrated expanding housing and dowel provide consistently stronger joints
- 'Klix' locking system

Quickloc™ Assembly

1. Press Quickloc into the face board

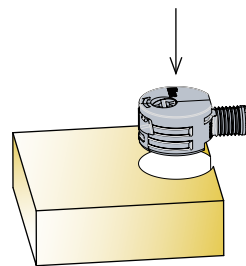

2. Assemble the panels

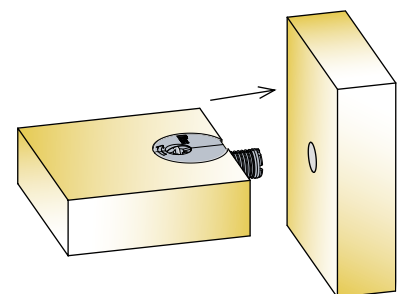



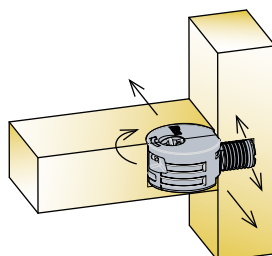





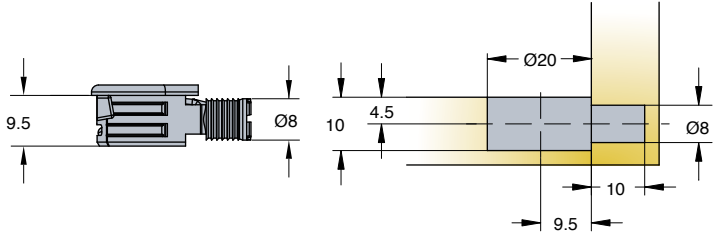

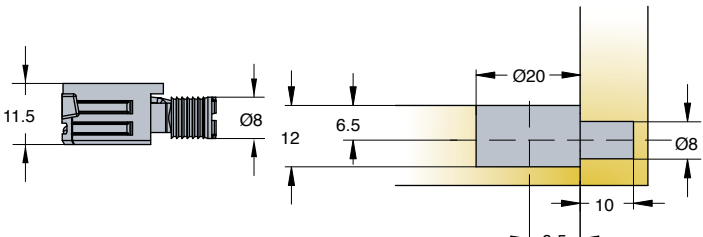
3. Tighten in less than one turn

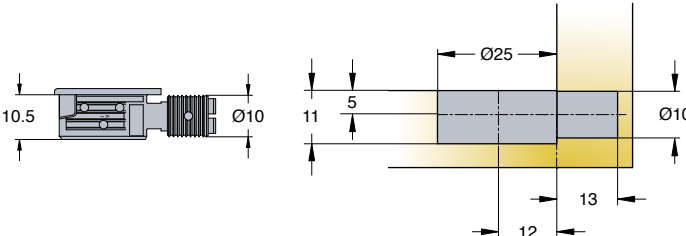

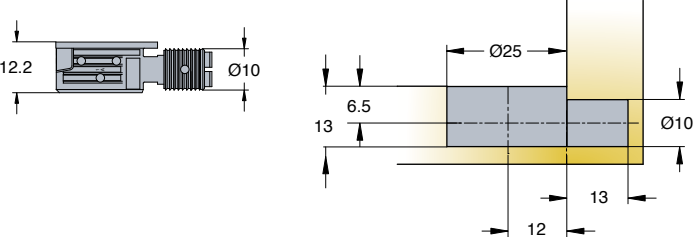
System 4 Quickloc™ One Piece Expanding Connector

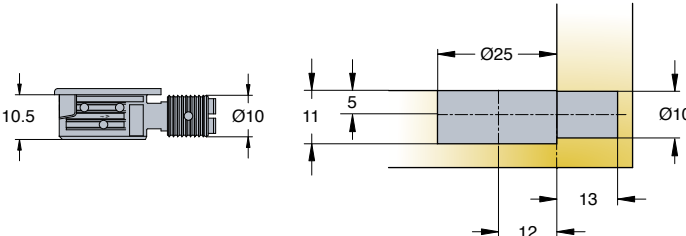







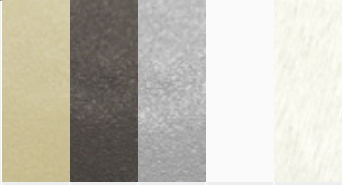
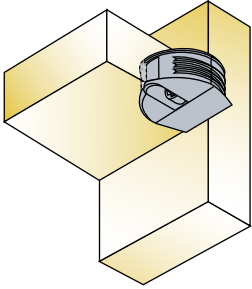

- An innovative, one-piece connector, capable of hand insertion
- Highly tolerant and tightens in less than one turn
- Face-bored product
- Offers a high degree of drilling tolerance and is the only connector of its type to provide pull-up of cabinet panels when tightened

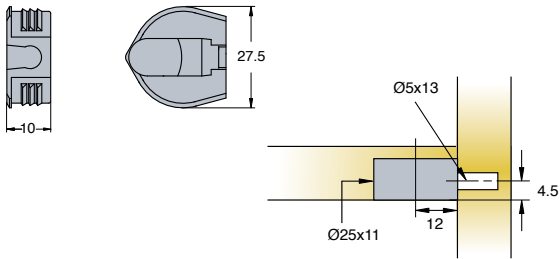
Technical and mounting details		Color options			
		Dark brown	Black	White	
		Item number	Dark brown	Black	White
Quickloc Ø20 flanged 		06803 →	831	835	877
 2500 Pcs	Made of zinc, plastic				
Quickloc Ø20 flush 		06806 →	831	835	877
 2500 Pcs	Made of zinc, plastic				
Quickloc Ø25 flanged 		06802 →	831	835	877
 1500 Pcs	Made of zinc, plastic				
Quickloc Ø25 flush 		06839 →	831	835	877
 1500 Pcs	Made of zinc, plastic				

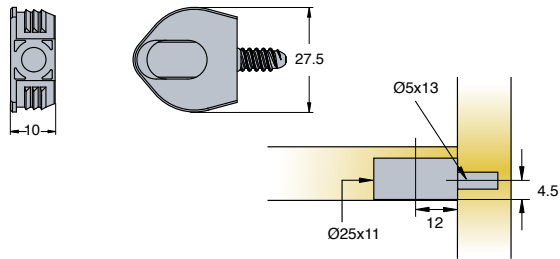
System 4 Fittings for Face-boring Only

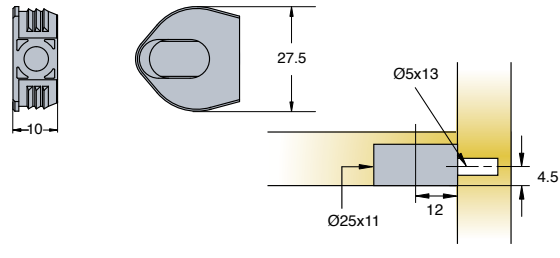
Flushbloc™ / Flushfix™

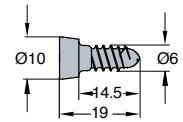
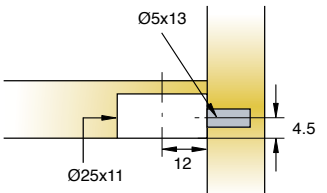
- The Angledrive screw provides high level of tolerance
- Face drilling only required
- Corner joint and shelf fixing options

						
		Brown beige	Black	Silver	White	Zinc
Technical and mounting details		Item number				
						
Flushfix™    2500 Pcs Made of plastic		02161 →	806	861	877	
<i>Other colours on request</i>						
Flushbloc™ with screw    2000 Pcs Made of zinc and plastic		02193 →		835	877	
<i>Other colours on request</i>						
Flushbloc™ assembly    2500 Pcs Made of plastic		*02190 →		835	877	
<i>* American market only Other colours on request</i>						
Angledrive screw for use with Flushfix™     2000 Pcs Made of zinc	round head 00021 →					885
	flat head 00022 →					885











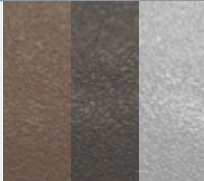

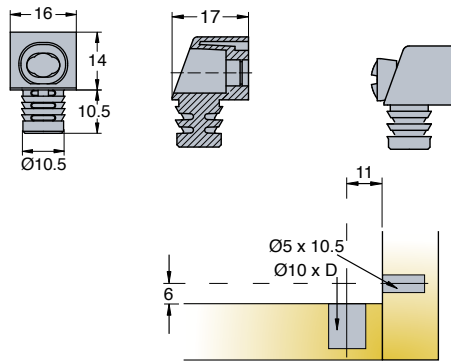
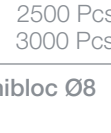
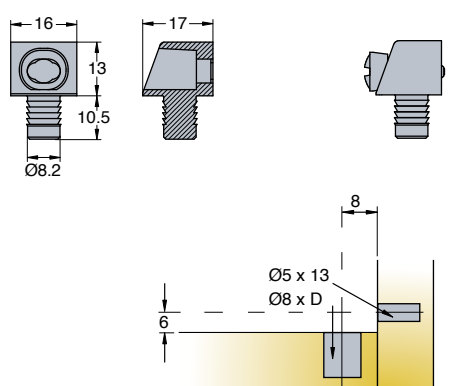
System 4

Fittings for

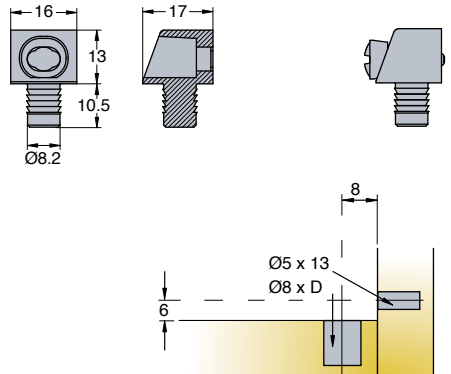
Face-boring Only

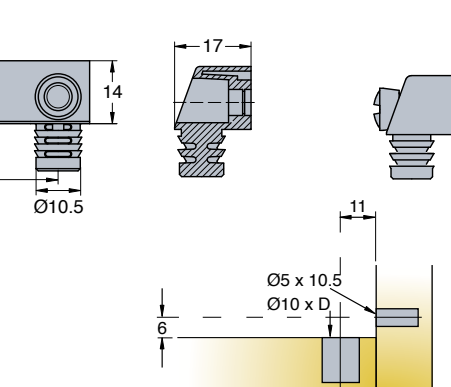
Minibloc™ / Twinbloc™

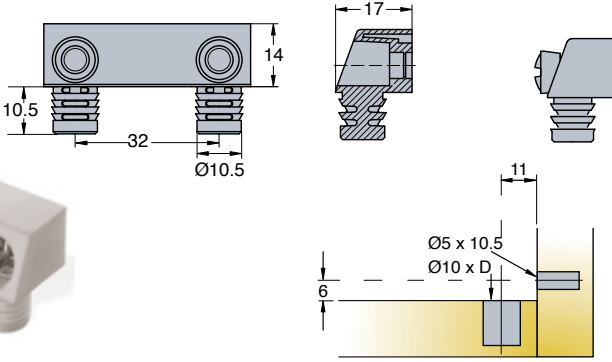
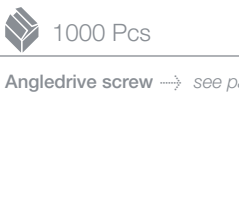
- One-piece connector range
- Face drilling only required
- Easy to use, foolproof home insertion
- Angledrive screw tolerates good levels of inaccurate drilling increasing consumer confidence

Technical and mounting details		D						
		Drilling depth	Dark brown	Black	Silver	White		
		Item number						
Minibloc Ø10 			11	02107 →	831	835	861	877
			11	* 02120 →	831	835	861	877
 2500 Pcs (02107)  3000 Pcs (02120)		Made of zinc, plastic	* Assembly with screw Other colours on request					
Minibloc Ø8 			11	02141 →		835	861	877
			11	* 02144 →		835		877
 3000 Pcs		Made of zinc, plastic	* Assembly with screw * European market only Other colours on request					
Twinbloc Ø10 			11	02130 →		835	861	877
			11	* 02139 →		835		877
 1000 Pcs		Made of zinc, plastic	* Assembly with screw Other colours on request					

Angledrive screw → see page 1.17

System 4 Fittings for Face-boring Only Cambloc

- Screw-on and knock-in versions are available
- Plastic housings are available in different colours
- Quick and intuitive assembly when fittings are pre-mounted on furniture

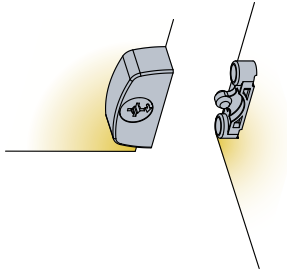

Technical and mounting details

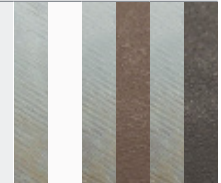

Zinc plated + white housing

Zinc plated + brown housing

Zinc plated + black housing

Item number

Screw-on

279-9187 →

960

970

980

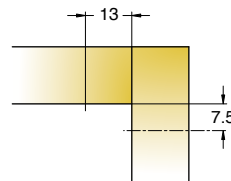
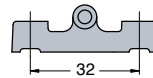
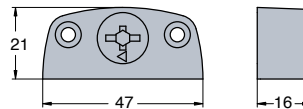

System 5 Cams and Dowels

System Features

The most advanced cam and dowel range

Titus System 5 is a comprehensive range of cam and dowel connecting fittings with 'Klix' and Quickfit features for all cabinet applications: panel-to-panel, panel-to-hollow profile, back-to-back

Dowels

- **Quickfit TL5, 'Full metal jacket'**
a high performance Quickfit dowel for use in multiple wooden materials
- **Quickfit TL2, TL4, TL5 dowels**
a unique solution for factory pre-insertion, high level of drilling tolerances

- **Quickfit dowels**
quick hand insertion, easy assembly
- **Diecast dowels (zinc)**
precise manufacturing, optimal shape and design
- **Turned dowels (steel)**
'traditional' design, smooth surface, best strength performance
- **Combi dowels (zinc and steel)**
high precision of zinc, strength of steel, 100% dimensional accuracy and optimal performance

Titus 'Klix'TM

Titus 'Klix' locking system ensures the engagement of the interlocking teeth on cam and dowel providing:

- vibration-proof joint
- rigid construction that will not loosen in service or transit

Dowel insertion time comparison

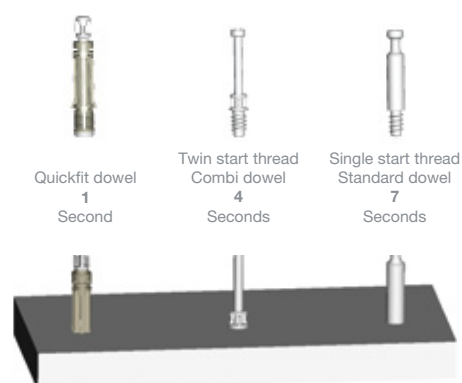

2 o'clock lock Smooth closing

Linear cam profile assures smooth, firm tightening action and greater pull-up. The cam always locks at 2 o'clock lock (230°), enabling greater consumer confidence in use while improving furniture quality.

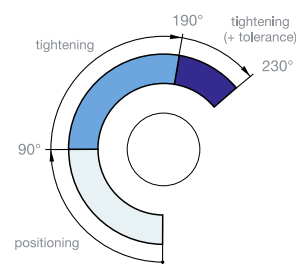

Drilling tolerances

Optimal performance and perfect joint even with inaccurate drillings.

Zinc/Combi dowel

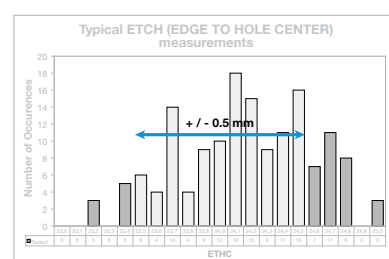
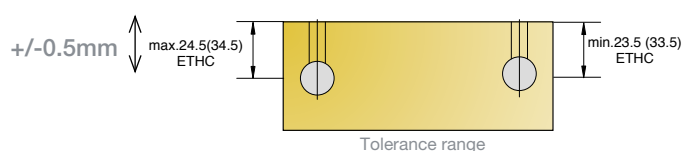

Quickfit TL5 dowel, Quickfit TL2 dowel

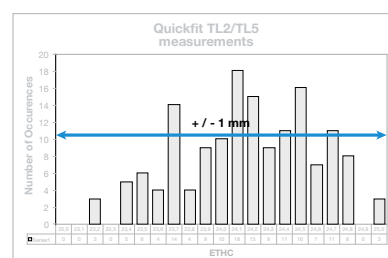
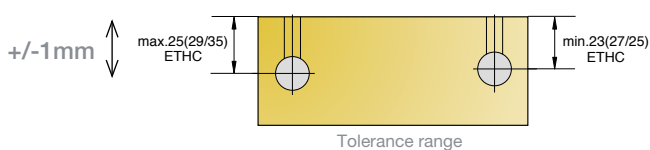

Quickfit TL4 dowel

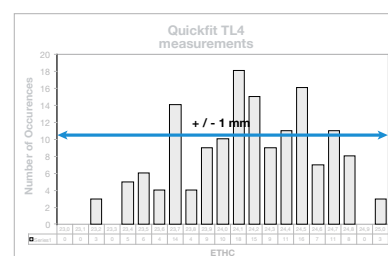
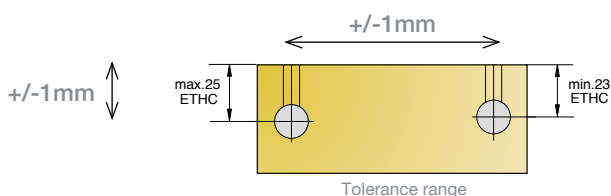

ETHC=Edge To Hole Center

Dowels for factory insertion

Quickfit TL5, Quickfit TL4 and Quickfit TL2 are the only available dowels allowing factory preinsertion

- Easier packing
- Less damages in handling
- Perfect for the RTA market

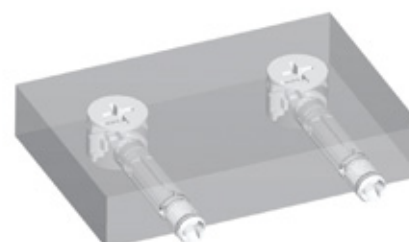

System 5 Cams and Dowels

Cam5000

Highly resistant joint for strong cabinet construction

Reinforced cam evenly engages the hole and prevents cam tilting and cam bursting.

Increased joint resistance enables effective performance in wider tolerance range.



Linear cam profile

Linear cam profile ensures:

- Smooth tightening action
- Greater dowel pull-up



Cam retaining pips

Cam retaining pips ensures:

- The cam is held in position prior to assembly
- Secure cam positioning during transport and handling
- Accurate factory insertion



2 o'clock lock

Smooth and noticeable locking at the 2 o'clock position guarantees:

- always-right tightening for home assembly
- strong and rigid cabinet construction

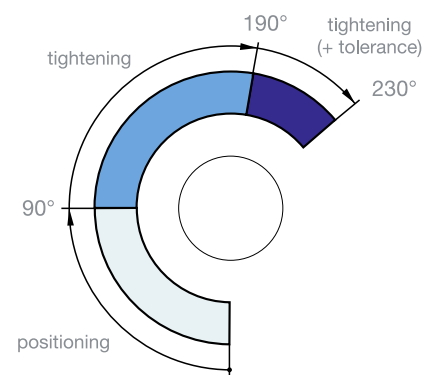

Optimised cam profile

Optimised cam profile ensures smooth and tight joint with no gap between panels.

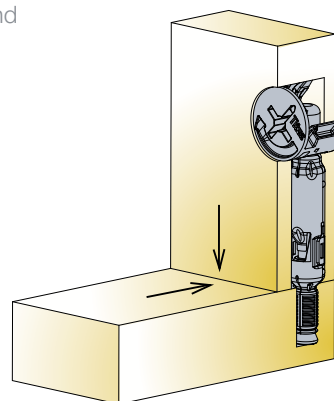

Optimal performance with all Titus dowels

Quickfit TL, Quickfit, Combi, end, double ended, angled and other screw-in dowels



System 5 Cams and Dowels

Quickfit Connectors

It is the fastest assembly system on the market. The Quickfit™ dowel may be inserted by hand, using only finger pressure. This eliminates the labour intensive process of screw-in assembly and the potential panel damage.

The Quickfit™ range of dowels has been extended to provide a complete family of fittings available in diameters of 5mm, 8mm, 10mm and lengths of 24mm and 34mm. These dowels are compatible with the range of Titus Ø15mm cams.

Assembly

1. Press the cam into face board

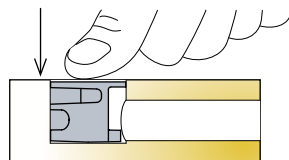

2. Insert the dowel into side panel

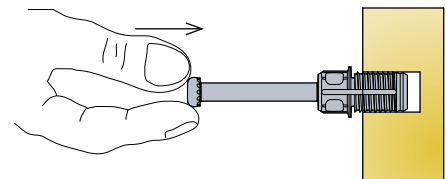

3. Assemble the panels

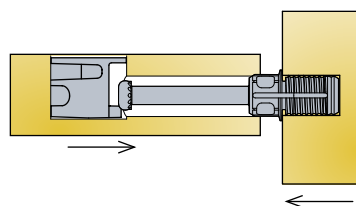

4. Tighten the cam to lock dowel

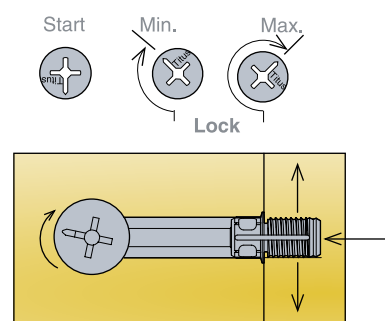

5. Assembled panels

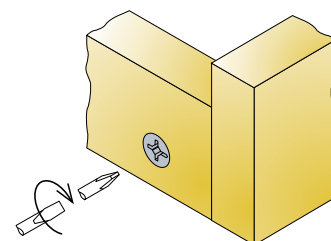

Quickfit TL Connectors

Quickfit-TL™ dowel offers furniture manufacturers a fast assembly system providing high drilling tolerances. It has a built-in self-adjustment feature, which enables common drilling inaccuracies to be overcome.

For the self-assembly furniture consumer, Titus Quickfit-TL™ is the most consumer friendly fitting on the market. Apart from the benefit of fully tightened joints and easy locking into the same position, Quickfit-TL™ provides an exceptionally smooth action when tightened, requiring very little effort.

Drilling tolerances

Marginal inconsistencies of drilling and the problems associated with the natural movement of wood panels, no longer present problems.

Quickfit-TL™ provides a tolerance of ± 1 mm on drilling operation while ensuring that the final result is a perfectly precise and aligned joint. No other assembly fittings system can offer such tolerances and still maintain a perfect joint.

Assembly

1. Press the cam into face board



2a. Either push dowel into edge hole or...

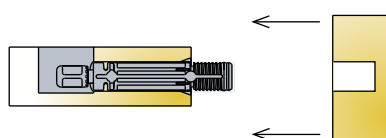

2b. Insert the dowel into side panel

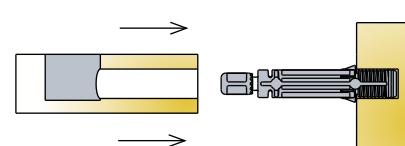

3. Assemble the panels

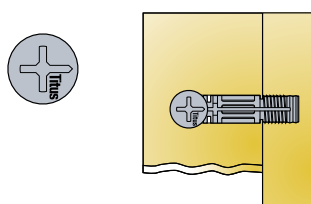

4. Tighten cam to lock dowel

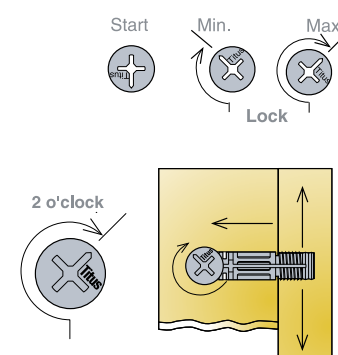

System 5 Cams and Dowels

Quickfit TL5 'Full Metal Jacket'

Effective performance in multiple wooden materials

- Smooth and noticeable locking at the 2 o'clock position guarantees:
- tight joints
 - always-right tightening at home assembly
 - strong and rigid cabinet construction

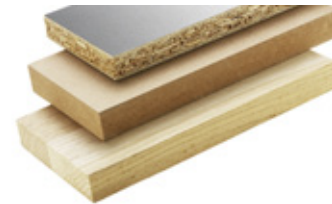

Strong and reliable joint

Expanding steel sleeve assures high resistance to torsion and pull-out.

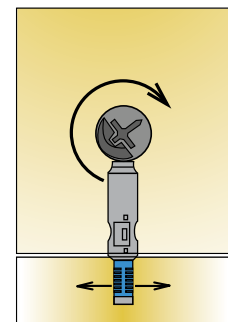

High drilling tolerances

An extended dowel head design works as a positive stop against the cam and provides an ETHC tolerance of min. +/-1mm

Fully tightened joint assured even at marginal inconsistencies of drilling and problems associated with the natural movement of wood panels.

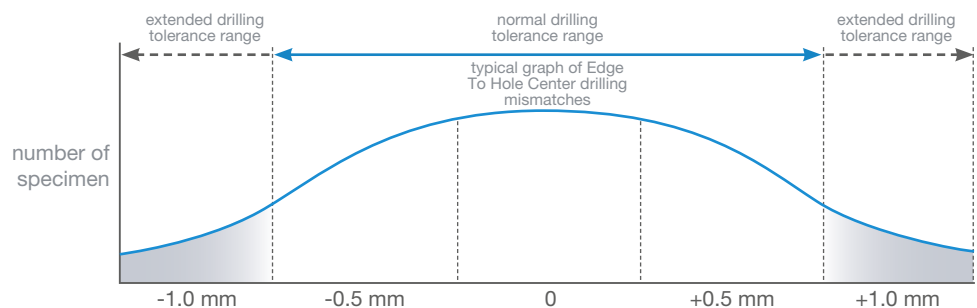
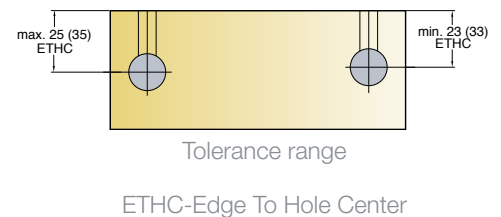

Shape of dowel sleeve

- Acts as a positive stop when inserted
- Ensures correct insertion depth



Tool-free insertion for Ø5mm dowel holes

Quickfit TL5 reliably engages the 5mm dowel hole. It enables the usage of tool-less Quickfit dowel insertion technology across a wide range of applications.

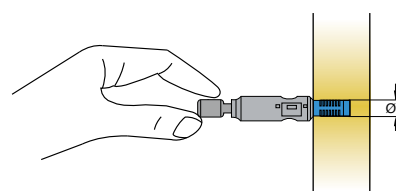

50% less time to assemble the cabinet at home

When edge inserted the dowel engages the cam and remains securely positioned until the boards are locked together.

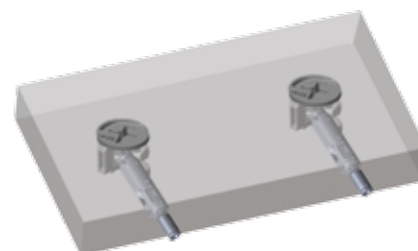

For maximum efficiency the insertion process can be automated using the Titus proprietary Lama FastFit machine.

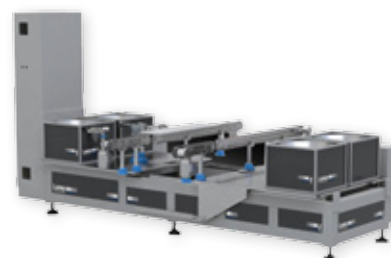

Fast and easy cabinet assembly at home.

CAF Quick & Easy

Consumer Assembly Friendliness

System 5 Cams and Dowels

Zinc+steel Combi Dowels

**Zinc+steel
technology for
optimal strength
and performance**

The Combi dowel combines steel and a small amount of zinc to ensure high precision and dimensional accuracy, essential to provide furniture manufacturers with the broadest possible range of drilling tolerances.

toroidal head form

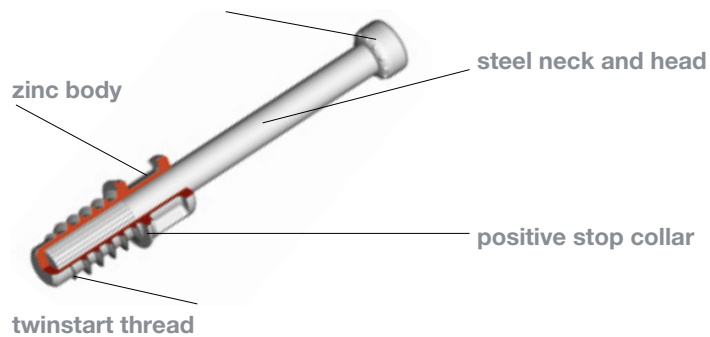

The steel neck and head provide better resistance to torsion and pull-out enabling a high performance joint

Zinc body:
Positive stop collar ensures correct insertion depth
Twinstart for faster and more stable insertion

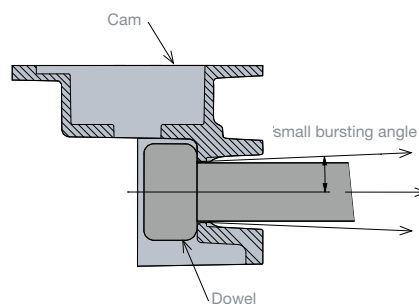

The toroidal dowel head form transfers the forces between cam and dowel more effectively resulting in a small cam bursting force.

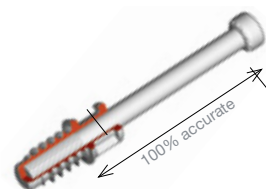

**100% dimensional accuracy
assured**

System 5

Quickfit TL5

'Full Metal Jacket'

- Tool-free insertion technology for Ø5mm dowel holes
- Drilling tolerances of +1/-1mm when edge inserted
- Expanding steel sleeve assures a strong joint, highly resistant to pull-out
- Functions in multiple wooden materials (chipboard, MDF, solid wood)
- Suitable for use with Cam5000

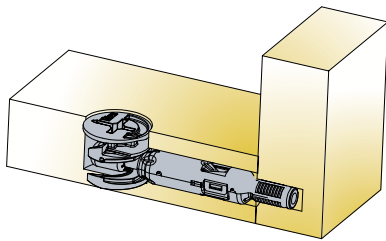

Technical and mounting details

Quickfit TL5 dowel

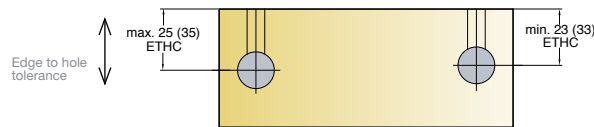
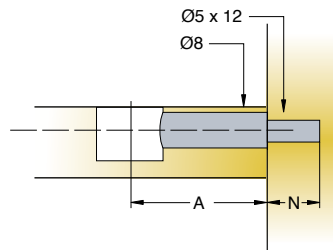
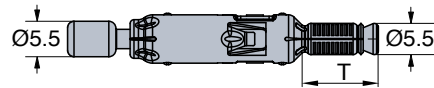

Tolerance range

A	N	T	Item number	TeraBlack
Drilling distance	Drilling depth	Drilling length		
34	12	11.5	09652 →	956
24	12	11.5	09651 →	956



To be used with Cam5000 only

1000 Pcs

Made of steel

System 5

Cams and Dowels

Quickfit TL Dowels

- Available in Ø5mm and Ø8mm for panel-to-panel applications
- Suitable for use with all Ø15mm Cam2000, Cam3000, Cam3000 S and Cam5000 products
- 'Klix' locking feature provides a strong, vibration proof joint
- Highly tolerant in edge-inserted, TL4 also in face-inserted applications

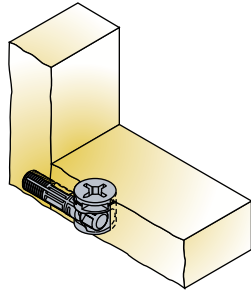

Technical and mounting details

Quickfit TL2

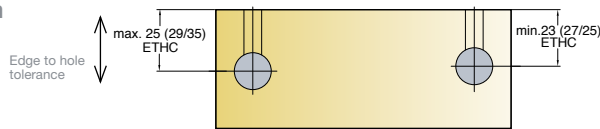
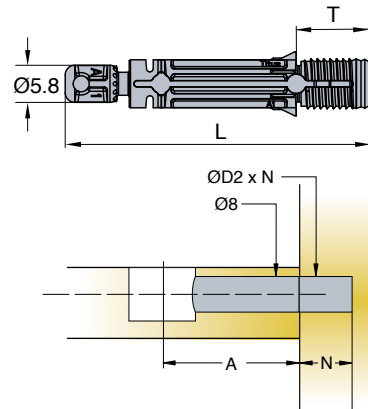

Tolerance range

2000 Pcs
1000 Pcs (05474)

Made of zinc, plastic

Quickfit TL4

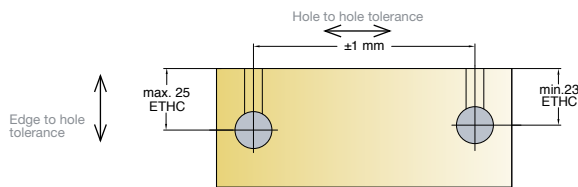
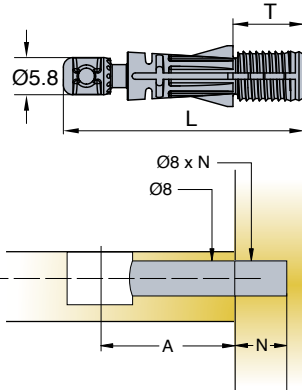

Tolerance range

3000 Pcs

Made of zinc, plastic

A	N	T	D2	Item number	Black	Dark grey
Drilling distance	Drilling depth	Thread length	Drilling diameter for dowel thread			
24	12	11.5	5	05453 →		880
34	12	11.5	5	05503 →		880
24	12	11.2	8	05366 →		880
28	12	11.2	8	05314 →		880
34	12	11.2	8	05474 →		880
24	12	11.2	8	05388 →	835	

System 5

Cams and Dowels

Quickfit Dowels

- Available in Ø5mm, Ø8mm and Ø10mm for panel-to-panel applications
- Suitable for use with all Ø15mm Cam2000, Cam3000, Cam3000 S and Cam5000 products
- 'Klix' locking feature provides a strong, vibration proof joint
- Depth stop collar for accurate insertion

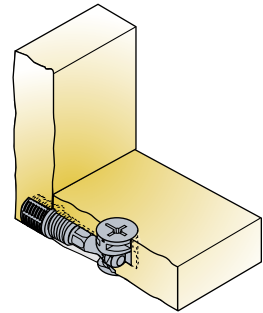

Technical and mounting details

Quickfit dowel
Ø8mm

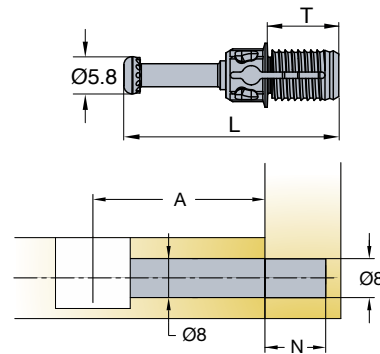

1000 Pcs (05556,05552)
2000 Pcs (05563, 05554)

Made of zinc, plastic

Quickfit dowel
Ø10mm

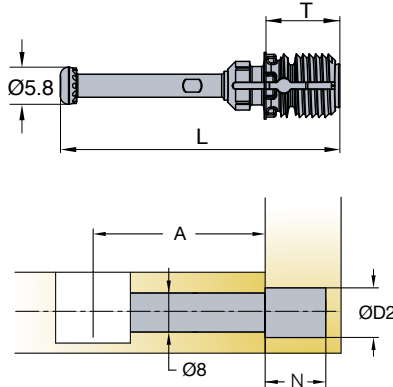

2000 Pcs

Made of zinc, plastic

Quickfit dowel
For back-to-back application

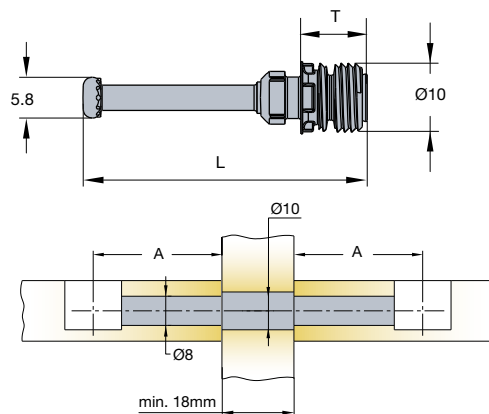

1000 Pcs

Made of zinc, plastic

A	N	T	L	Item number	Dark grey
Drilling distance	Drilling depth	Drilling distance	Total length		
20	12	11.2	29.5	05556 →	880
24	12	11.2	33.5	05563 →	880
28	12	11.2	37.5	05552 →	880
34	12	11.2	43.5	05554 →	880
24	12	11.2	33	05052 →	880
34	12	11.2	43	05050 →	880
24	12	11.2	30.5	05270 →	880
34	12	11.2	40.5	05147 →	880

System 5

Cams and Dowels

Quickfit P2F Dowels

- The only product to enable standard panel drilling and connection of panel and hollow profile
- Available in Ø8mm for panel-to-hollow metal profile applications
- Suitable for use with all Ø15mm Cam2000, Cam3000, Cam3000 S and Cam5000 products
- 'Klix' locking feature provides a strong, vibration proof joint

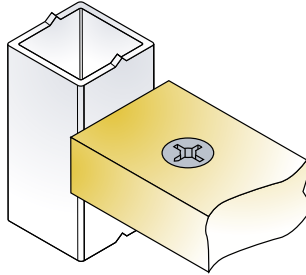

Technical and mounting details

Quickfit P2F

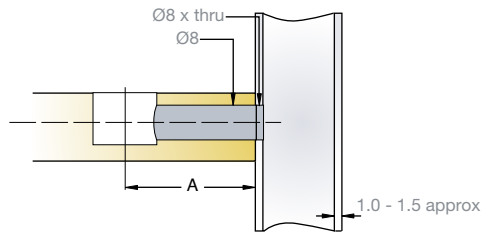
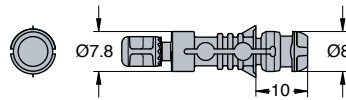

A

Drilling distance

Item number

Black

24

05414 →

835

2000 Pcs

Made of zinc, plastic

System 5

Cams and Dowels

Combi Dowel

- High quality zinc-steel dowel with greater resistance to torsion and pull-out
- Suitable for use with all Ø12mm and Ø15mm Cam2000, Cam3000 S and Cam5000 products
- 'Klix' locking feature provides a strong, vibration proof joint
- Twinstart thread for faster and reliable insertion

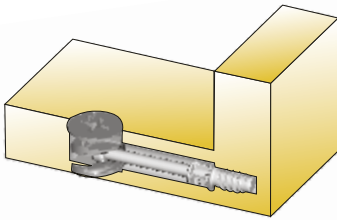

Technical and mounting details

Combi dowel Ø5

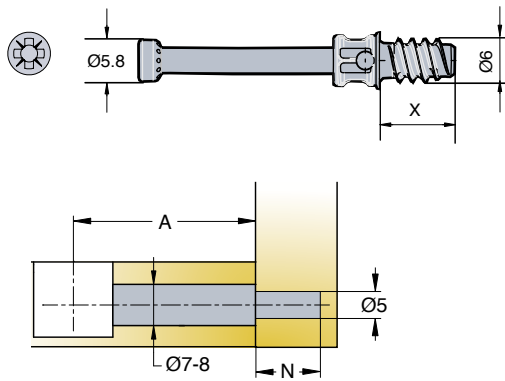

PH2 head
PH2 head
PH2 head

A	N	X	Item number	Zinc
34	12	11	09435 →	885
28	10	9.5	09588 →	885
24	12	11	09443 →	885
24	9	8.5	09583 →	885
34	12	11	*09424 →	885
24	12	11	*09423 →	885
34	9	8.5	*09456 →	885
<i>*American market only</i>				

1000 Pcs
*2000 Pcs

Made of steel and zinc

Combi dowel M6

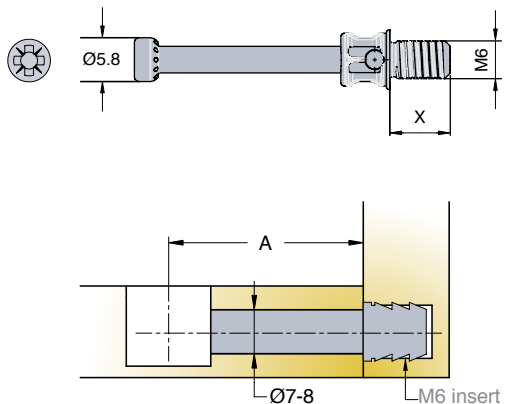

34		8	09592 →	885
34		10.5	09594 →	885

1000 Pcs

Made of steel and zinc



→ see page 1.59







→ see page 1.59

System 5

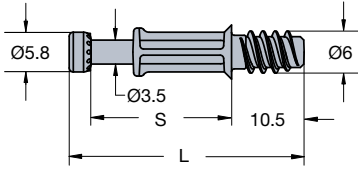
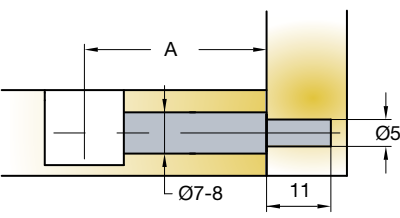
Cams and Dowels

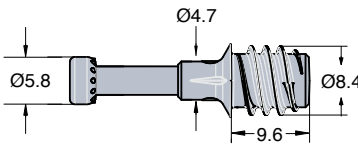
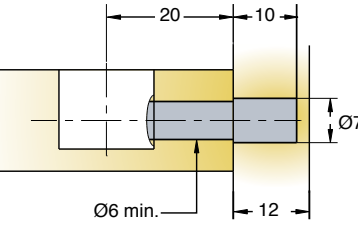
Combi Dowel

		S	L	A		
Technical and mounting details		Length	Total length	Drilling distance	Item number	Zinc
Combi dowel Ø5 Full body		20.6	34.5	24	09597 →	885
	 					
 1000 Pcs	Made of steel and zinc					
Combi dowel Ø7				20	09430 →	885
	  					
 1000 Pcs	Made of steel and zinc					

 Inserts
Made of plastic

→ see page 1.59

System 5

Cams and Dowels

Double-ended Dowel

- Available in Ø7mm
- Suitable for use with all Ø12mm and Ø15mm Cam2000, Cam3000, Cam3000 S and Cam5000
- No circlip for increased tolerance
- Available in a variety of lengths to suit most panel-to-panel applications

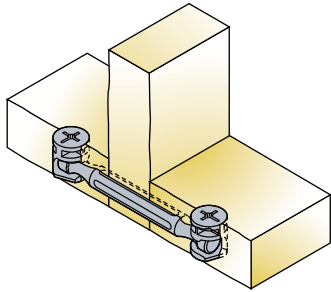

Technical and mounting details

Dowel without circlip

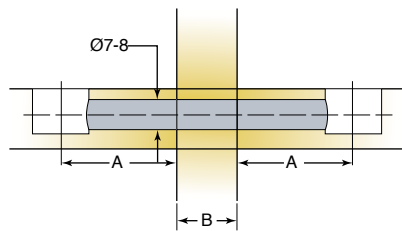
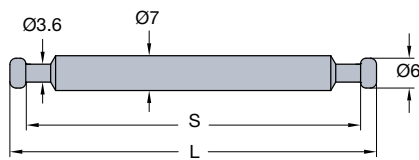

- 250 Pcs (05753)
- 500 Pcs (05857)
- 1000 Pcs (05929)

Made of steel

Dowel with circlip

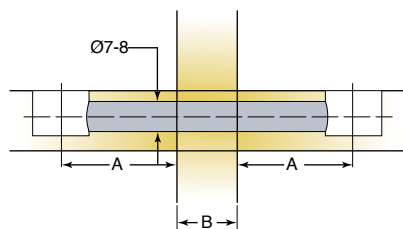
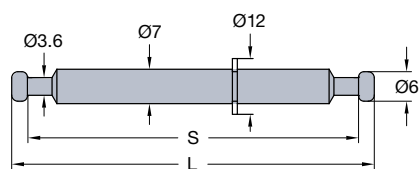

- 250 Pcs
- 500 Pcs (05775, 05774)

Made of steel

S	L	A	B	Item number	Zinc plated
Length	Total length	Drilling distance	Panel thickness		
41	47.4	24	0*	05929 →	883
61	67.4	34	0*	05757 →	883
77	83.4	34	16	05858 →	883
79	85.4	34	18	05859 →	883
80	86.4	34	19	05753 →	883
56	62.4	24	15	05592 →	883
57	63.4	24	16	05857 →	883
59	65.4	24	18	05380 →	883
60	66.4	24	19	05778 →	883
*B=0 → no panel required					

77	83.4	34	16	05752 →	883
79	85.4	34	18	05772 →	883
80	86.4	34	19	05751 →	883
57	63.4	24	16	05775 →	883
60	66.4	24	19	05774 →	883

System 5

Cams and Dowels

Angled Dowels

- Suitable for applications requiring angled joints
- Suitable for use with all Ø12mm and Ø15mm Cam2000, Cam3000, Cam3000 S and Cam5000
- Adjustable angle from 90° to 180°

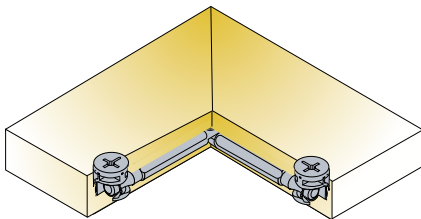

Technical and mounting details

Item number

Zinc plated

Angled dowel
180° fixed

05860 →

883

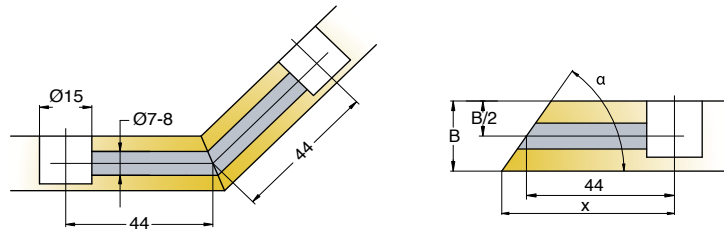

Distance x in mm

Q	20°	25°	30°	35°	40°	45°	50°	55°	60°	65°	67,5°	70°	75°	80°	85°		
13	61.9	57.9	55.3	53.5	51.7	50.5	49.5	48.6	47.8	47	46.7	46.4	45.7	45.1	44.6		
15	64.6	60.1	57	54.7	52.9	51.5	50.3	49.3	48.3	47.5	47.1	46.7	46	45.3	44.7		
16	66	61.2	57.9	55.4	53.5	52	50.7	49.6	48.6	47.7	47.3	46.9	46.1	45.4	44.7		
B	18	68.8	63.3	59.6	56.9	54.7	53	51.6	50.3	49.2	48.2	47.7	47.3	46.4	45.6	44.8	
	19	70.1	64.4	60.5	57.6	55.3	53.5	52	50.7	49.5	48.4	47.9	47.5	46.5	45.7	44.8	
	22	74.2	67.6	63.1	59.7	57.1	55	53.2	51.7	50.4	49.1	48.6	48	46.9	45.9	45	
	23	75.6	68.7	63.9	60.4	57.7	55.5	53.6	52.1	50.6	49.4	48.8	48.2	47.1	46	45	x

250 Pcs

Made of steel

Angled dowel
90° fixed

05282 →

883

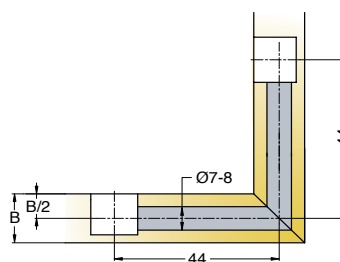

1000 Pcs

Made of steel

System 5

Cams and Dowels

End Dowels

- Available in a variety of head and length combinations to suit most end panel applications
- Suitable for use with all Ø12mm and Ø15mm Cam2000, Cam3000, Cam3000 S and Cam5000
- 'Klix' locking feature provides a strong, vibration proof joint
- Both 'mushroom' and countersunk headed versions available

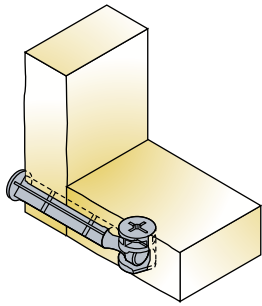

Technical and mounting details

Mushroom dowel

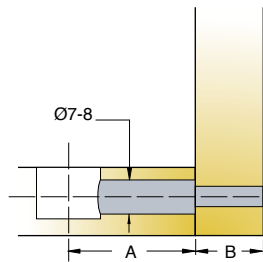
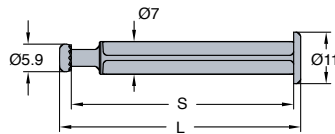

A	B	S	L	Item number	Zinc
Drilling distance	Panel thickness	Length	Total length		
24	16	36.5	40.5	05608 →	885
24	19	39.5	43.5	05609 →	885
34	16	46.5	50.5	05610 →	885
34	19	49.5	53.5	05611 →	885

500 Pcs (05610, 05611)
1000 Pcs (05608, 05609)

Made of zinc

System 5

Cams and Dowels

Ø15mm Cam5000

- Improved central shape for highly resistant joint
- Suitable for use with all Titus dowels
- 'Klix' locking feature provides a strong, vibration proof joint
- Cam retaining pips ensure that a cam is held in panel position prior to assembly

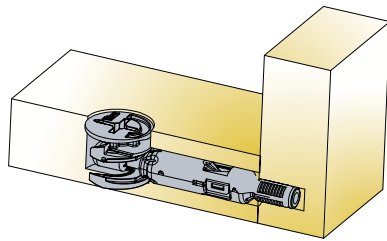

Technical and mounting details

B	D	e	h	Item number	Zinc
Panel thickness	Drilling depth	Drilling for dowel	Cam height		

Cam5000
cross drive

PZ2 drive

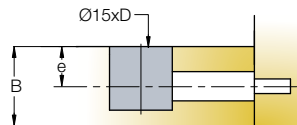
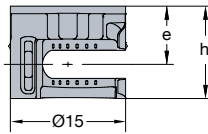

12/13	10.5	6 min	9.9	09695 →	885
15/16	12.5	7.5/8	11.9	09690 →	885

Use standard cover caps with pin=Ø4mm

1000 Pcs

Made of zinc

Cam5000
hexagonal drive

combined drive with HEX

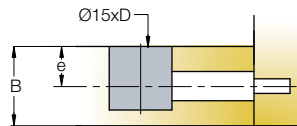
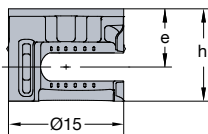

15/16	12.5	7.5/8	11.9	09699 →	885
18/19	14	9/9.5	13.2	09692 →	885

Use standard cover caps with pin=Ø4mm

Black available upon request

1000 Pcs

Made of zinc

System 5

Cams and Dowels

Ø15mm Cam3000 S

- Innovative design offers optimal performance with maximum cost effectiveness
- Suitable for use with Combi dowels, forged steel dowels and Quickfit dowels
- 'Klix' locking feature provides a strong, vibration proof joint
- Cam-retaining pins ensure that a cam is held in panel position prior to assembly

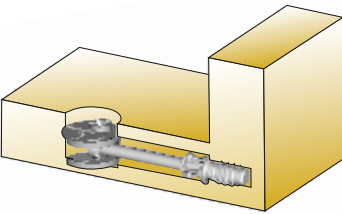

Technical and mounting details

B	D	e	Item number	Zinc	Zinc corrosil
Panel thickness	Drilling depth	Drilling for dowel			

Cam3000 S/15

PZ2 drive

15/16	12.5	7.5/8	09491 →	885	897
-------	------	-------	----------------	-----	-----

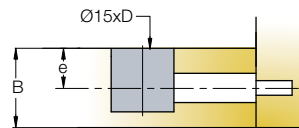
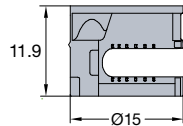

1000 Pcs

Made of zinc

Cam3000 S/12

PZ2 drive

12 min	9.5 min	min 6	*09406 →	885	897
--------	---------	-------	-----------------	-----	-----

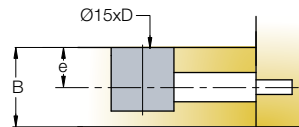
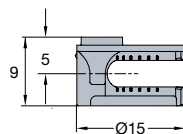

** European market only*

2000 Pcs

Made of zinc

Cam3000 S/12

Philips PH2 drive

12 min	9.5 min	min 6	*09631 →	885	
--------	---------	-------	-----------------	-----	--

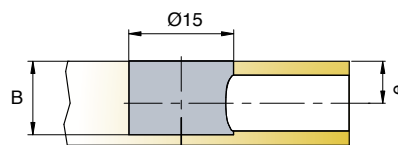
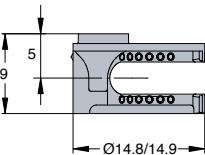

** American market only*

1000 Pcs

Made of zinc



Cover caps 09630
Made of plastic

System 5

Cams and Dowels

Ø15mm Cam3000

- Its optimised shape provides a more efficient cam profile with smooth tightening action and greater dowel pull-up
- Suitable for use with Combi dowels, forged steel dowels, Quickfit dowels and Quickfit TL dowels
- 'Klix' locking feature provides a strong, vibration proof joint
- Cam-retaining pips ensure that a cam is held in panel position prior to assembly

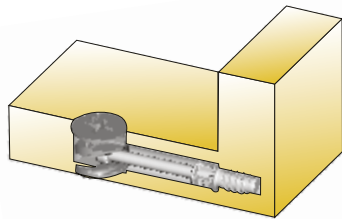

Technical and mounting details

B	D	e	h	Item number	Zinc
Panel thickness	Drilling depth	Drilling for dowel	Cam height		
12/13	10.5	6 min	9.9	09495 →	885
15/16	12.5	7.5-8	11.9	09533 →	885

Cam3000 cross drive

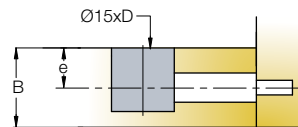
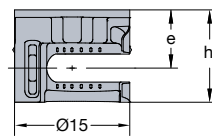

Black available upon request

1000 Pcs

Made of zinc

Cam3000 hexagonal drive



combined drive with HEX

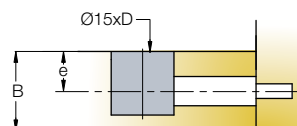
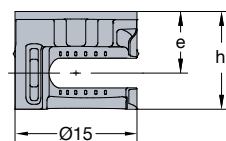

15/16	12.5	7.5-8	11.9	09537 →	885
18/19	14	9-9.5	13.2	09536 →	885

Use standard cover caps with pin=Ø4mm

Black available upon request

1000 Pcs

Made of zinc

System 5

Cams and Dowels

Ø15mm Cam2000

- Available in a variety of head, drive recess and board thickness versions to suit most applications
- Suitable for use with all Titus dowels
- 'Klix' locking feature provides a strong, vibration proof joint
- Linear cam profile results in smooth, easy cam rotation and dowel pull-up

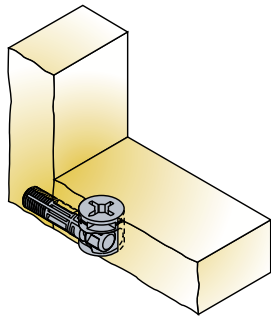

Technical and mounting details

B	D	e			
Panel thickness	Drilling depth	Drilling for dowel	Item number	Nickel	Zinc

Cam2000
Ø15

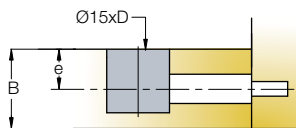
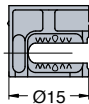

12/13	10min	6-6.5	*05587 →	847	885
15/16	12.7	7.5-8	05654 →	847	885
22/23	16	11-11.5	05657 →	847	885
25/26	17.9	12.5-13	05676 →	847	885
28/29	19.4	14-15.5	05678 →	847	885

Other finishes on request

***Ultraflat** - specially designed for thin panels
(does not work with TL dowels)

500 Pcs (05676, 05678)
1000 Pcs

Made of zinc

Cam2000
Ø15 headed

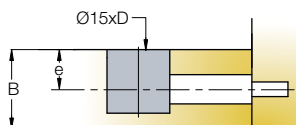
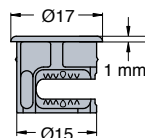

12	10min	6	*05586 →	847	885
13	10.9min	6.5	05652 →	847	885
16	12.9	8	05658 →	847	885
19	13	9.5	05659 →	847	885
23	14.5	11.5	05675 →	847	885
26	16.5	13	05677 →	847	885
29	19.4	14.5	05679 →	847	885

Other finishes on request

***Ultraflat** - specially designed for thin panels
(does not work with TL dowels)

500 Pcs (05675, 05677, 05679)
1000 Pcs

Made of zinc



Cover caps for Ø15 cams
Made of plastic

→ see page 1.65

System 5

Cams and Dowels

Ø12mm Cam2000

- Suitable for all Titus screw-in dowels
- Available in a variety of head, drive recess and board thickness versions to suit most applications
- Particularly suited to drawer front attachment applications
- 'Klix' locking feature provides a strong, vibration proof joint
- Linear cam profile results in smooth, easy cam rotation and dowel pull-up

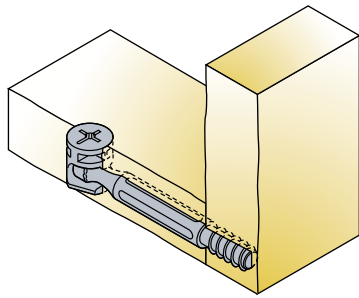

Technical and mounting details

B	D	e					
Panel thickness	Drilling depth	Drilling for dowel	Item number	Black painting plate	Nickel plated	Zinc	Corrosil zinc
12/13	10 min	6-6.5	05575 →	838	847	885	897
15/16	12	7.5-8	05578 →			885	
18/19	13 min	9-9.5	05580 →			885	
<i>Other finishes on request</i>							

Cam2000
Ø12

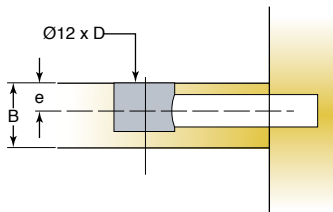
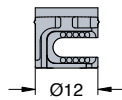

2000 Pcs

Made of zinc

Cam2000
Ø12 headed

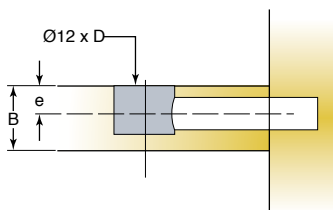
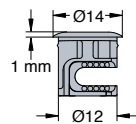

1000 Pcs
2000 Pcs (05576)

Made of zinc

12	9.2 min	5.25	05574 →	838	847	885	897
12	10 min	6	05576 →			885	
16	12.5	8	05579 →			885	
<i>Other finishes on request</i>							







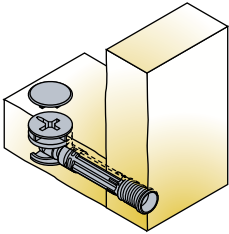
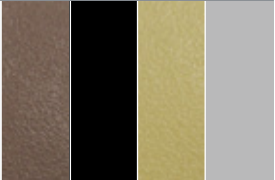

Cover caps for Ø12 cams
Made of plastic

→ see page 1.65

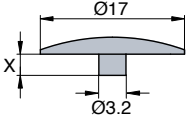
System 5 Cover Caps

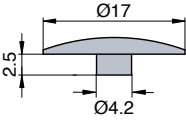
- Available in a variety of colours
- Suitable for use with both pozi and hex cam drive features
- Suitable for use with various diameter cams
- Both domed and flat versions available

 Technical and mounting details		X					
			Pin length	Item number	Dark brown	Black	Light brown
Cover cap Ø17 		3.3	*01029 →	834	835	867	882
		2.5	277-4355 →	370	390	330	380
 1000 Pcs Made of plastic		*American market only Other colours on request Suitable for cams with Pozi 2 recess					
Cover cap Ø17 			277-4225 →	370	390	330	380
		Other colours on request Suitable for cams with Hex recess					
 1000 Pcs Made of plastic							

System 6

Quickfit-Expando

Connectors

System Features

A face boring connector family for 32mm system drilling with full range of panel and application variants for all cabinet manufacturing applications

- Minimum drilling requirements
- Linear cam design for constant tightening loads when driving
- Angledrive feature on cam for maximum driving comfort
- Interchangeable pins for wood, plastic and steel applications
- Pins with twinstart drive for fast insertion
- Interchangeable Quickfit pin fastenings available
- Tool-less fastening capable versions
- Back-to-back fastenings for common vertical panel fixing of shelves

System 6 consists of a range of 20mm diameter housing, Quickfit™ and conventional dowels, end dowels and double ended dowels.

Housings are made from high grade plastic or zinc, with zinc cams.

Wedgefix-6 connector is a special fastener without cam, simply to snap onto a pre-inserted dowel.

Applications

Titus System 6 is ideal for use in high volume production of case goods, closet and garage storage systems. Because no

edge boring is required, it is an excellent choice for manufacturing environments with limited drilling capacity.

Side-entry Drop-on

Side-entry insertion of shelf panel: from the side or from the top

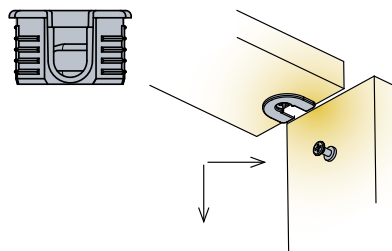

Drop-on insertion of shelf panel: only from the top
Using drop-on connections allows for one-man installation

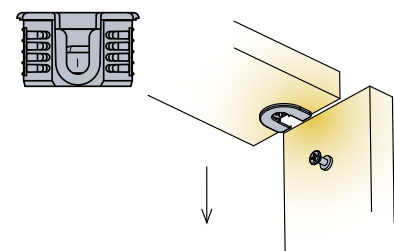

Angledrive feature

The angledrive feature on the cam allows for the angled position of the screwdriver with the locking action creating a tight and secure joint.

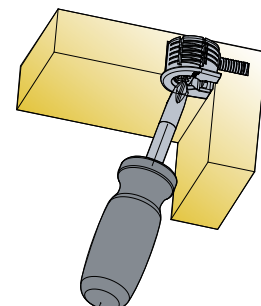

System Features

Outrigger/ Non outrigger

Outrigger

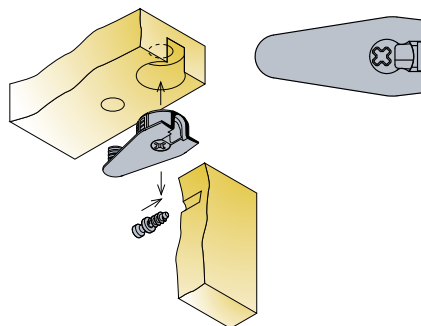

Non outrigger

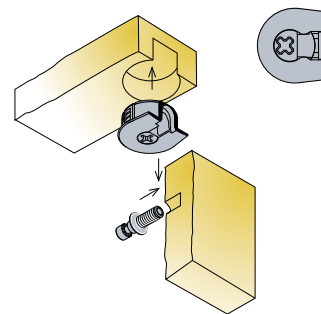

Expando function

Expanding housings and dowels provide a tight joint.

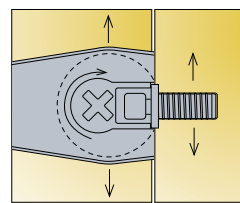
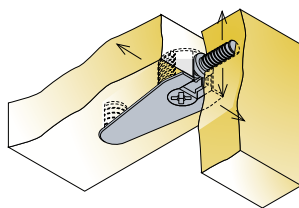

Assembly

1. Press the housing into face board

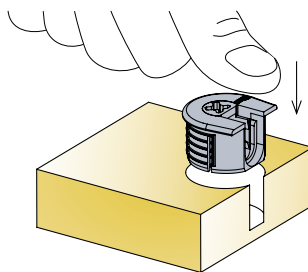

2. Press the dowel into side panel

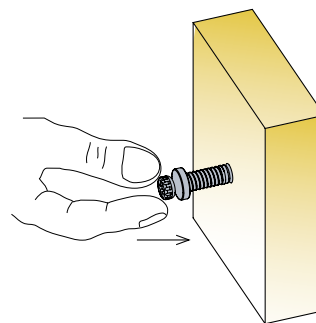

3. Assemble the panels

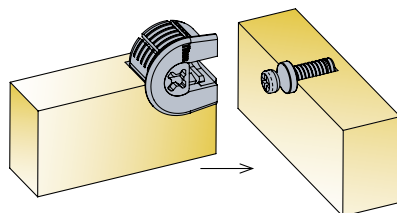

4. Tighten the joint

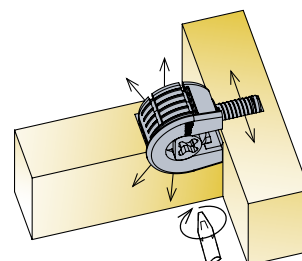





System 6

Quickfit-Expando

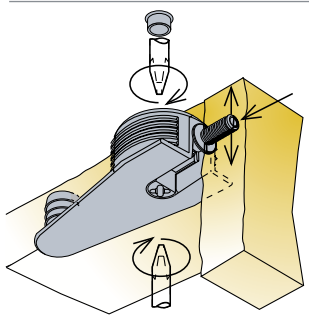

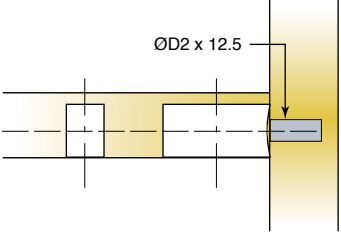

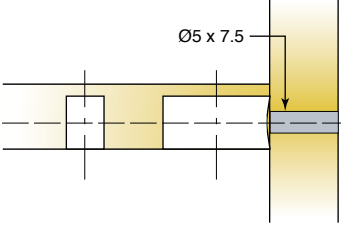



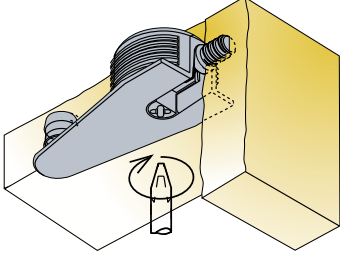

Expanding Dowels

- Available in Ø5mm, Ø8mm for panel-to-panel, and back-to-back applications
- Suitable for applications with all Titus Ø20 and Sys 6 housings
- 'Klix' locking feature provides a strong, vibration proof connection
- Depth stop collar for accurate insertion

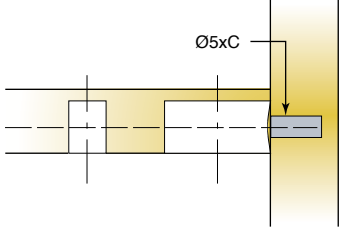
 <p>Technical and mounting details</p>	D2	Drilling diameter for dowel thread	Item number	Dark grey
<p>Dowel</p>  <p>D2= Ø5mm</p>  <p>D2= Ø8mm</p>  <p>Ø2 x 12.5</p> <p>5000 Pcs Made of zinc, plastic</p>		<p>5</p> <p>8</p>	<p>06408 →</p> <p>06410 →</p>	<p>880</p> <p>880</p>
<p>Dowel Ø5 x 7.5 back-to-back applications</p>   <p>Ø5 x 7.5</p> <p>5000 Pcs Made of zinc, plastic</p>		<p>5</p>	<p>06479 →</p>	<p>880</p>

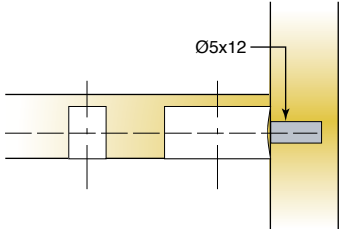
System 6 Quickfit-Expando Dowels

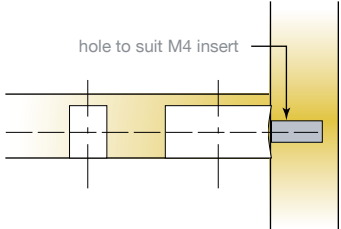
- Available in various Ø3mm and/or Ø5mm thread forms for screw-in, knock-in and/or 'spiked' hole applications
- Suitable for applications with all Titus Ø20mm and Sys 6 housings
- 'Klix' locking feature provides a strong, vibration proof connection
- Dowels feature an integral skirt which acts as a positive stop during insertion

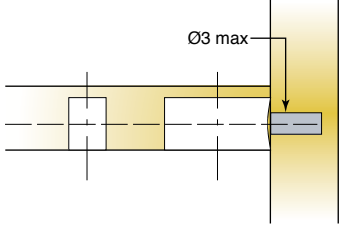
 Technical and mounting details		C	Drilling depth for dowel thread	Item number		
					Zamak	Zinc plated
Dowel Ø5    2000 Pcs Made of zinc or steel	9	06401 →	885			
	8	06402 →	885	883		
	11.5	06406 →	885	883		
Dowel Ø5 x 11 knock-in    2000 Pcs Made of zinc		06403 →	885			
Dowel M4 x 7    4500 Pcs Made of steel		06405 →		883		
Dowel Ø3 x 11.5    12500 Pcs Made of steel		06495 →		883		



 Inserts
 Made of plastic
 → see page 1.59

System 6

Quickfit-Expando

Double-ended Dowels

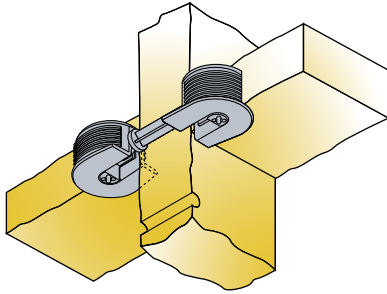
- For 16mm, 18mm and 19mm board
- Suitable for applications with all Titus Ø20mm and Sys 6 housings
- 'Klix' locking feature provides a strong, vibration proof connection



Technical and mounting details

Double-ended dowel

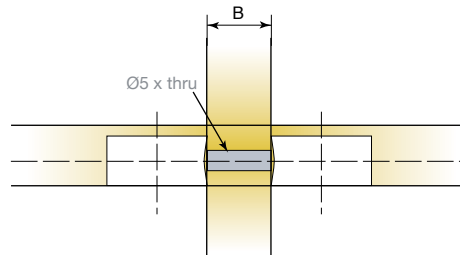
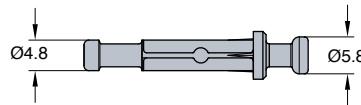

B	Item number	Zinc
Panel thickness		
16	06414 →	885
18	06413 →	885
19	06416 →	885

 2500 Pcs

Made of zinc

System 6 Quickfit-Expando End Dowels

- For 16mm, 18mm and 19mm board
- Suitable for applications with all Titus Ø20mm and Sys 6 housings
- 'Klix' locking feature provides a strong, vibration proof connection

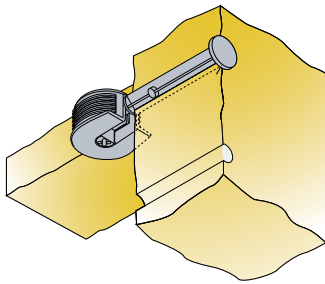

Technical and mounting details

End dowel

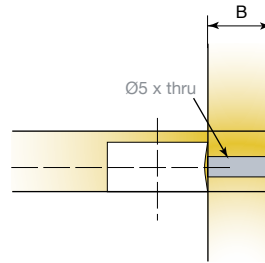
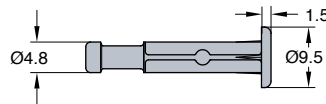

B	Item number	Zinc
Panel thickness		
16	06412 →	885
18	06411 →	885
19	06415 →	885

2000 Pcs
1000 Pcs (06411)

Made of zinc

System 6

Quickfit-Expando

20mm Expanding Housing

Non-outrigger

- Available in 15mm/16mm and 18mm/19mm versions for drop-on and/or side-entry applications
- Available in all-metal or plastic/metal options
- 'Klix' locking feature provides a strong vibration proof connection
- Compatible with all Sys 6 screw-in and Quickfit dowels

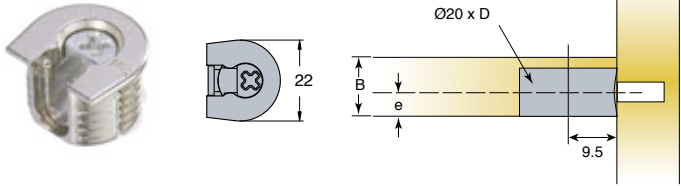
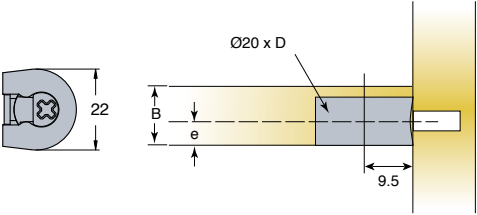
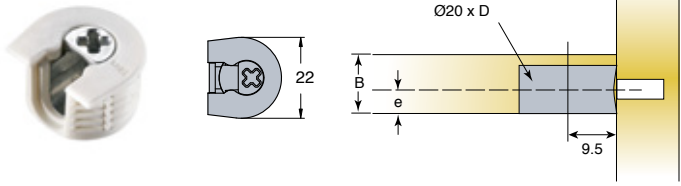
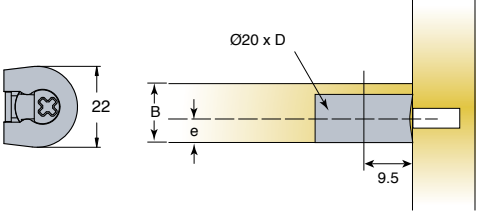
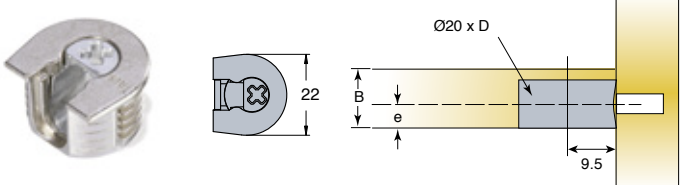
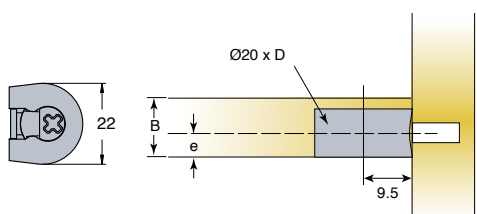
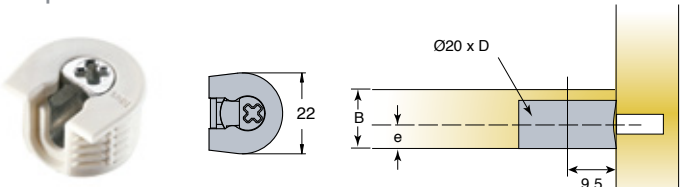
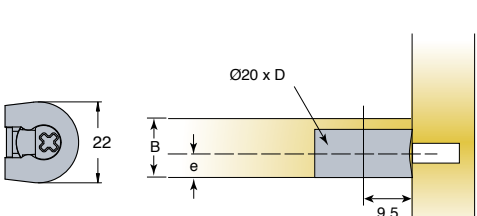
				e	B	D					
Technical and mounting details				Drilling for dowel	Panel thickness	Drilling depth	Item number	Dark brown plastic	Nickel plated	Silver plastic	White plastic
Side-entry				7.75	15/16	12.5	06451 →		847		
				9.25	18/19	14	06453 →		847		
500 Pcs				Made of zinc							
Side-entry				7.75	15/16	12.5	06435 →	831		861	877
				9.25	18/19	14	06437 →	831		861	877
2500 Pcs				Made of plastic							
<i>Other colours on request</i>											
Drop-on				7.75	15/16	12.5	06447 →		847		
				9.25	18/19	14	06449 →		847		
500 Pcs				Made of zinc							
Drop-on				7.75	15/16	12.5	06431 →	831		861	877
				9.25	18/19	14	06433 →	831		861	877
2500 Pcs				Made of plastic							
<i>Other colours on request</i>											







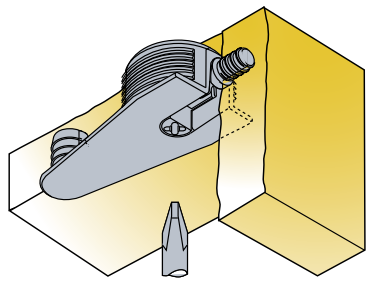

System 6

Quickfit-Expando

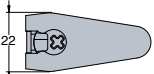
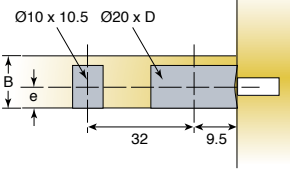
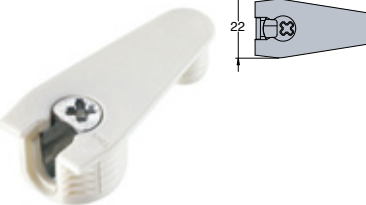
20mm Expanding Housing

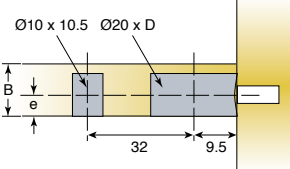
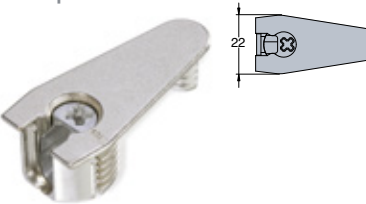
Outrigger

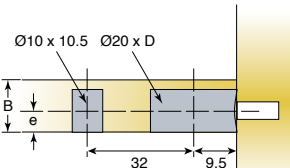
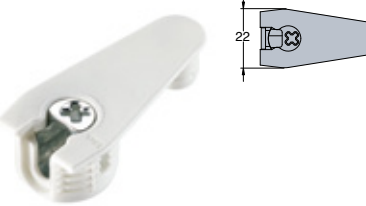
- Available in 15mm/16mm and 18mm/19mm versions for drop-on and/or side-entry applications
- Available in all-metal or plastic/metal options
- 'Klix' locking feature provides a strong vibration proof connection
- Compatible with all Sys 6 screw-in and Quickfit dowels

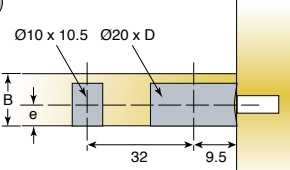
Technical and mounting details		e	B	D	Item number	Dark brown plastic	Black plastic	Nickel plated	White plastic
		Drilling for dowel	Panel thickness	Drilling depth					
Side-entry   500 Pcs Made of zinc	 	7.75	15/16	12.5	06459 →			847	
		9.25	18/19	14	06461 →			847	
Side-entry   1250 Pcs Made of plastic	 	7.75	15/16	12.5	06443 →				877
		9.25	18/19	14	06445 →	831	835		877
		9.25	18/19	14	*06395 →		835		877
<i>Other colours on request *American market only</i>									
Drop-on   500 Pcs Made of zinc	 	7.75	15/16	12.5	06455 →			847	
		9.25	18/19	14	06457 →			847	
Drop-on   1250 Pcs Made of plastic	 	7.75	15/16	12.5	06439 →		835		877
		9.25	18/19	14	06441 →	831	835		877
		9.25	18/19	14	*06397 →		835		877
<i>Other colours on request *American market only</i>									

System 6

Quickfit-Expando

Expanding Wedgefix Housing (no Inner Cam)

- Available in 12mm, 15mm/16mm and/or 18mm/19mm versions for Sys 6 screw-in and Quickfit dowel applications
- Available in a variety of plastic colours
- Wedgefix housing allows easy customer hand-assembly or factory automated insertion
- When used with Sys 6 Quickfit dowels this provides a true tool-less fastening system

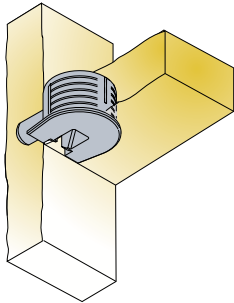

Technical and mounting details

For use with screw-in dowels

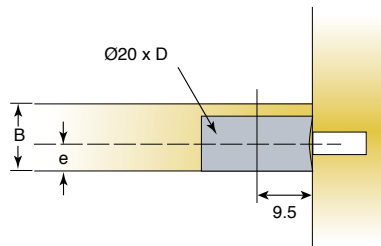
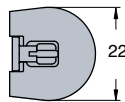

2500 Pcs

Made of plastic

For use with Quickfit dowels

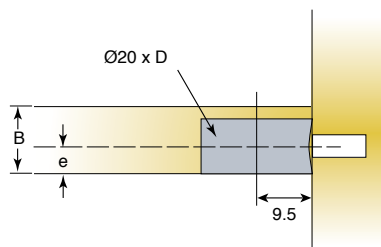
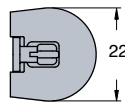

2500 Pcs

Made of plastic

e	B	D	Item number	White	Black	Dark brown	Silver
6	12	10	06470 →	877			861
7.75	15/16	12.5	06473 →	877	835	831	861
9.25	18/19	14	06465 →	877	835	831	861
11	22	16	06464 →				861
<i>Other colours on request</i>							
7.75	15/16	12.5	06471 →	877	835	831	861
9.25	18/19	14	06472 →	877	835	831	861
<i>Other colours on request</i>							

System 6

20mm Knock-in Housing

Non-outrigger

- Available in 15mm/16mm and 18mm/19mm versions for drop-on and/or side-entry applications
- Available in plastic-metal options
- 'Klix' locking feature provides a strong vibration proof connection
- Compatible with all Sys 6 screw-in and Quickfit dowels

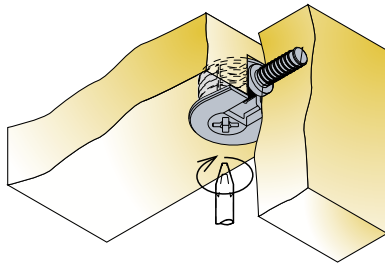

Technical and mounting details

e	B	D	Item number	Silver plastic	White plastic
Drilling for dowel	Panel thickness	Drilling depth			

Side-entry

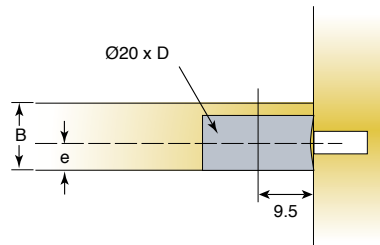
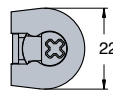

7.75	15/16	12.5	06381 →	861	877
9.25	18/19	14	06385 →	861	877

Product available on American and Asian market only

Other colours on request

2500 Pcs

Made of plastic

Drop-on

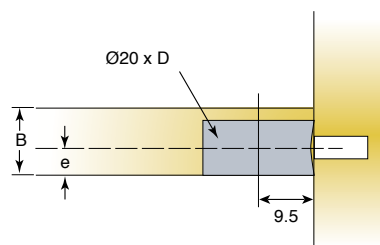
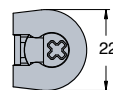

7.75	15/16	12.5	06383 →	861	877
9.25	18/19	14	06387 →	861	877

Product available on American and Asian market only

Other colours on request

2500 Pcs

Made of plastic

Cover cap 06936
Made of steel

System 6

Flush 20mm Knock-in Housing Non-outrigger

i For use with dedicated drill bit only.
See below.

- A face-boring connector with the flush housing permits easy flat-pack transportation without panel damage
- Available for 19mm board thickness for drop-on and/or side-entry applications
- 'Klix' locking feature provides a strong vibration proof connection
- Compatible with all Sys6 screw-in and Quickfit dowels

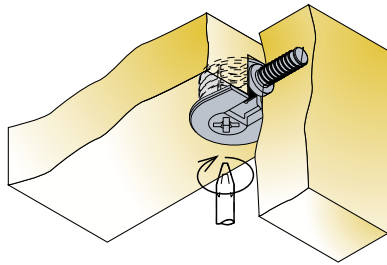

Technical and mounting details

e	B	D	Item number	White plastic
---	---	---	-------------	---------------

Side-entry

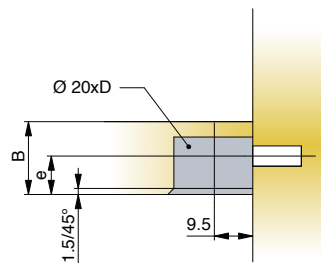
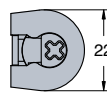

9.5	19	14.2	*06343 →	877
-----	----	------	----------	-----

*American market only

1000 Pcs

Housing made of plastic, cam made of zinc

Drop-on

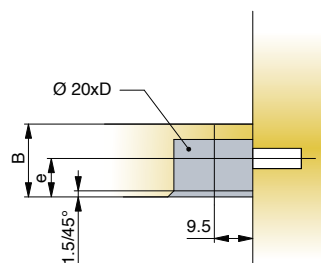
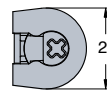

9.5	19	14.2	*06348 →	877
-----	----	------	----------	-----

*American market only

1000 Pcs

Housing made of plastic, cam made of zinc

Drill bit for Flush 20mm Knock-in housing

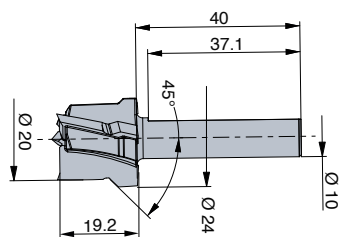

right handed

left handed

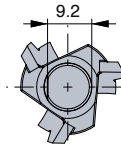

			00435	
			00436	

*American market only





1 Pcs

Made of carbon steel

System 7

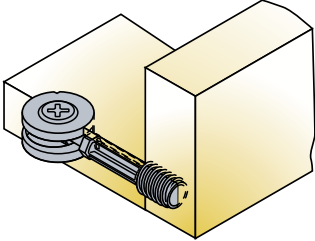
Heavy Duty Ø20mm Cam and Dowel

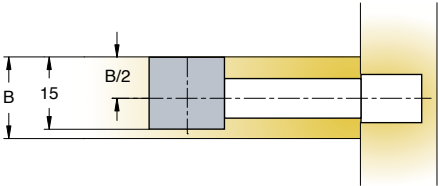
- Dowel available with Ø10mm eurothread and cam available in Ø20mm for a variety of panel thicknesses
- 'Klix' locking feature provides strong, vibration proof joint
- High strength product that eliminates the need for time consuming metal inserts

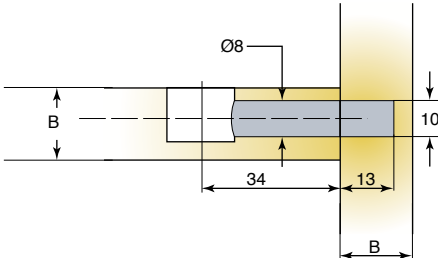





 <p>Technical and mounting details</p>	B	Panel thickness	Item number	Zinc
<p>Cam Ø20</p>   <p>500 Pcs Made of zinc</p>		18	05409 →	885
<p>Dowel Ø7 Ø10 mm thread</p>   <p>500 Pcs Made of zinc</p>		min 18	05410 →	885

System 7

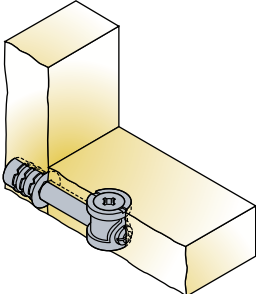
High Strength Connectors

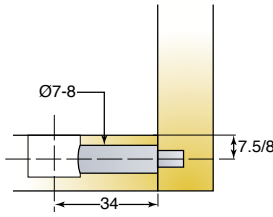
Contract Fix™ System

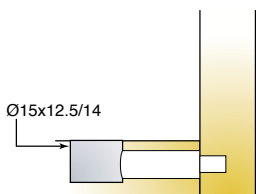







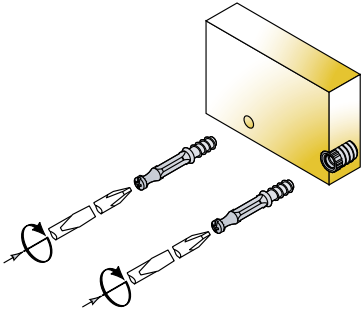

- High performance fastener
- Thread design gives repeatability
- Multi-drive recess
- Higher than average pull up

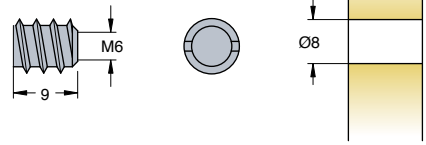
 <p>Technical and mounting details</p>	Item number	Zinc plated	Zinc
<p>M6 Dowel 7x34</p>   <p>1000 Pcs Made of steel</p>	05971 →	883	
<p>Housing cylinder 15x12</p>   <p>1000 Pcs Made of zinc</p>	05960 →		885
<p>Grub screw</p>  <p>2500 Pcs Made of zinc</p>	05917 →		885
<p>Inserts Made of zinc</p> <p>→ see page 1.59</p> 			

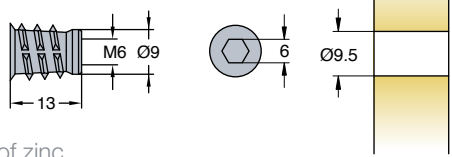
Accessories for Connectors

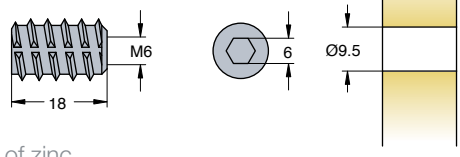
Inserts

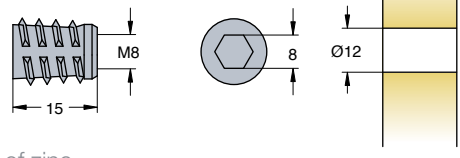

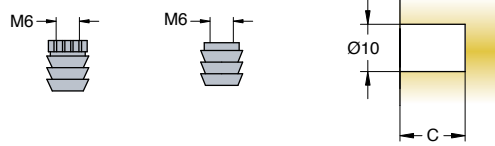





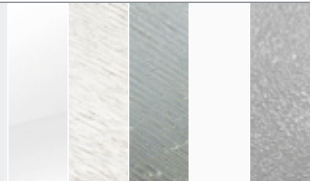
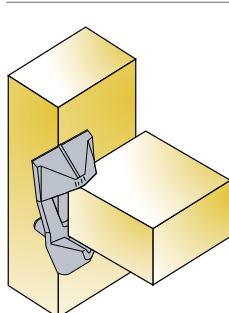

- Available in both zinc and plastic for use in various applications
- Suitable for use with various threaded dowels
- Suitable for use with various panel thicknesses
- Knock-in and screw-in versions available

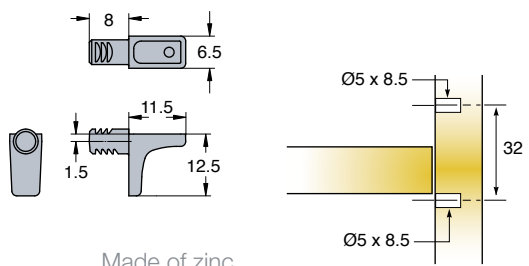
 <p>Technical and mounting details</p>		C	Drilling length for insert	Item number	Natural white	Raw
<p>Ø8 x 9</p>  <p>500 Pcs</p> <p>Made of zinc</p> 	<p>408-3166 →</p>		600			
<p>Ø9 x 13</p>  <p>1000 Pcs</p> <p>Made of zinc</p> 	<p>408-3391 →</p>		600			
<p>Ø9.5 x 18</p>  <p>1000 Pcs</p> <p>Made of zinc</p> 	<p>408-3423 →</p>		600			
<p>Ø12 x 15</p>  <p>1000 Pcs</p> <p>Made of zinc</p> 	<p>408-3424 →</p>		600			
<p>Ø10 x 13/M6 nut</p>  <p>20000 Pcs (275-4035) 30000 Pcs (275-4058)</p> <p>Made of plastic</p> 	<p>13 275-4035 →</p>	200				
	<p>11 275-4058 →</p>	200				

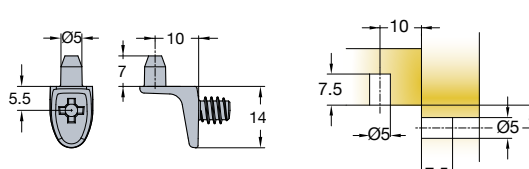
Cabinet Fittings

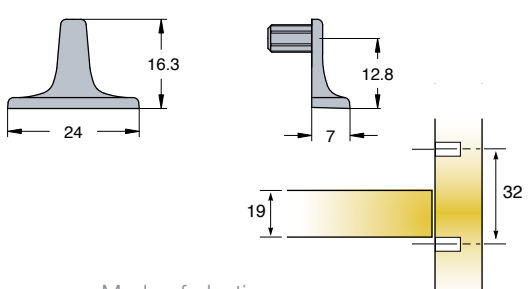
Shelf Supports

- Hold down feature traps the shelf in place for security
- Folding design allows the shelf to be post mounted in an assembled cabinet
- To suit a wide range of shelf thicknesses
- Pad for metal shelf support when using glass

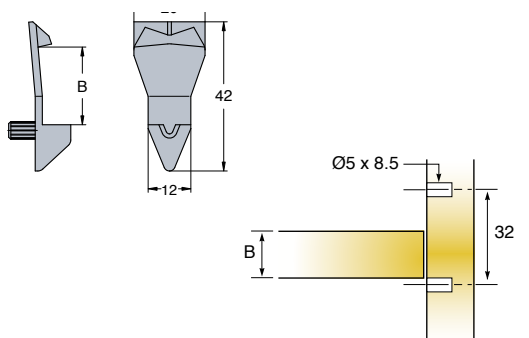
							
		B					
		Item number	Clear	Nickel	Zinc	White	Silver
		<p>Technical and mounting details</p>					
Shelf support (push-in)   2000 Pcs Made of zinc		01825 →		847	885		
Shelf support (push-in)   2000 Pcs Made of zinc		01852 →		847			
Shelf holddown (for use with 01825)   12000 Pcs Made of plastic		01822 →					861
Shelf support retainer   4000 Pcs  5000 Pcs (01837) Made of plastic		15	01837 →			877	
		16	01838 →	830			
		16	*01828 →			877	
		18	01823 →	830		877	861
		19	01829 →			877	
		19	01843 →	830			
		* American market only Other colours on request					

Shelf Supports

Mounting procedure:

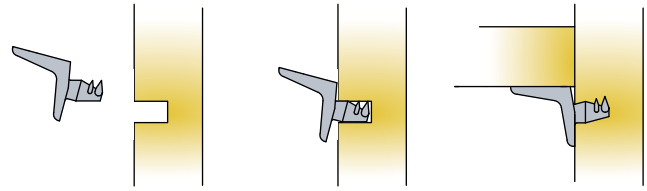



			Technical and mounting details	Item number	Nickel plated
Pin Ø5x10 (screw-on)				338-3687 →	650
1000 Pcs	Made of zinc				
For glass shelves (rock-in)				338-9721 →	860
1000 Pcs	Made of zinc and plastic				
Pin Ø5x10 (rock-in)				338-3686 →	650
1000 Pcs	Made of zinc				
Shelf support Ø3mm with pin				01912 →	847
2000 Pcs	Made of zinc				

Shelf Supports

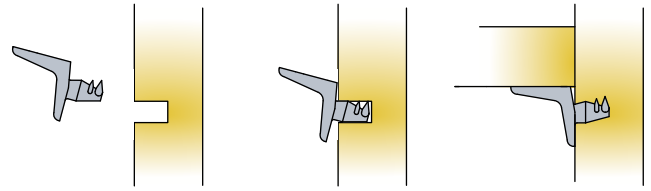
Mounting procedure:

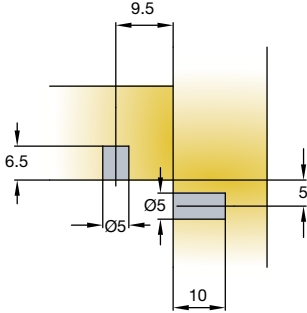

Technical and mounting details		Item number	Nickel plated
<p>Shelf support with pin</p>   	01910 →	847	
 2000 Pcs	Made of steel		
<p>Shelf support</p>   	01911 →	847	
 2000 Pcs	Made of steel		
<p>Shelf support with pin</p>   	01916 →	847	
 2000 Pcs	Made of steel		

Joining Plates

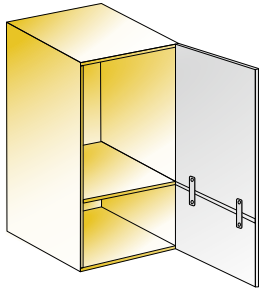

- Rigid and strong
- No pre-drilling
- Spacer pegs provide an even 2mm gap
- Sleek design



Technical details

Item number

Nickel plated

Joining plate 105mm

360-1222 →

054

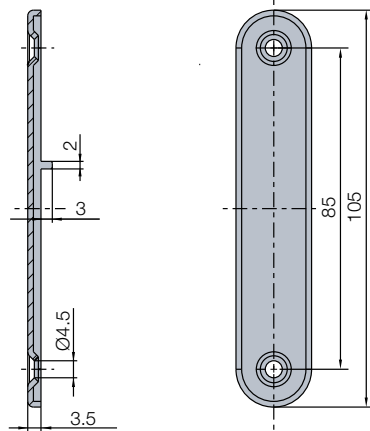

500 Pcs

Made of steel

Joining plate 43mm

360-1230 →

054

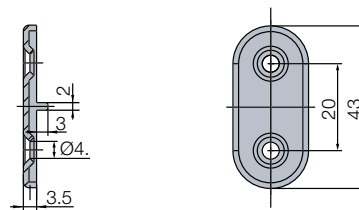

1000 Pcs

Made of steel

Fixing screw for cruciform mounting plate
If not pre-mounted

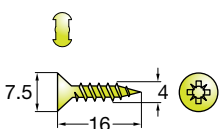

Chipboard screws
820-6328-050

10000 Pcs

No-Tools Backfix and Wall Connectors

- Push Backfix into panel
- No tools required to lock the Backfix panels together
- The handle on Backfix acts as a stop during locking, providing greater accuracy and speed of insertion
- Barbs on the Backfix provide a quality fastener for rigid cabinet construction

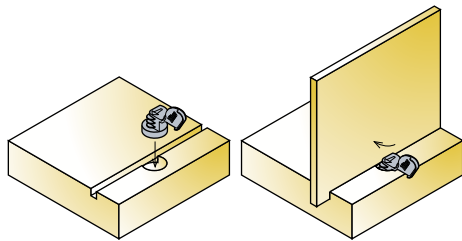

Technical and mounting details

Hardboard Backfix

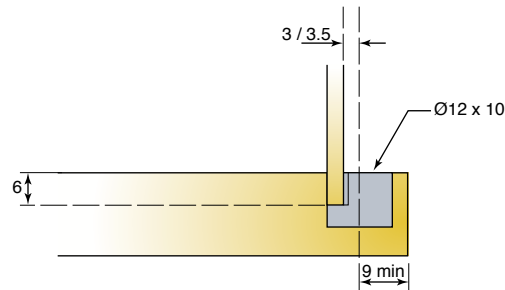

1000 Pcs

Made of zinc

Item number

02154 →

Nickel plated

Zinc

Corrosil

885

897

Rear wall connector long

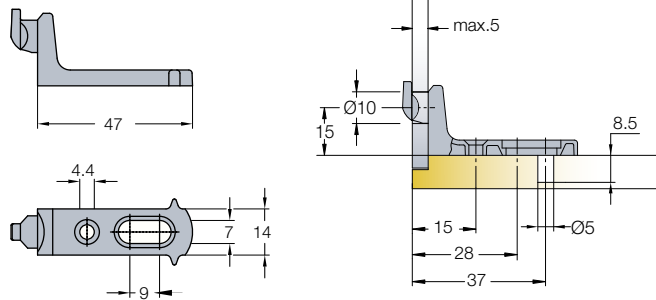

500 Pcs

Made of zinc

353-3649 →

650

Rear wall connector short

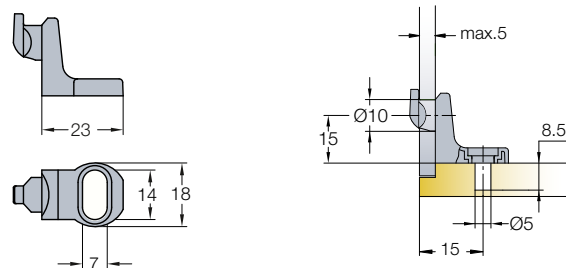

500 Pcs

Made of zinc

353-3650 →

650

Panel Brackets

- To be used to fix face frames to carcasses without additional drilling to cabinet
- Designed for carcase side panel of 18mm thickness
- Edge to hole centre = 28mm
- Easier fixing of frames due to parts that remain in holes once inserted

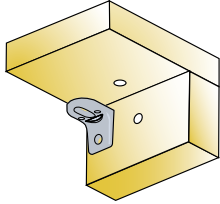

Technical and mounting details



Item number	Nickel plated	Zinc
02111 →	847	885

90° Bracket (screw-in/rock-in peg)

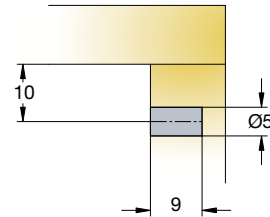
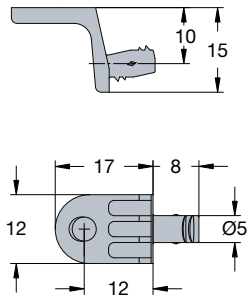

1000 Pcs

Made of zinc

90° Bracket (screw-in)

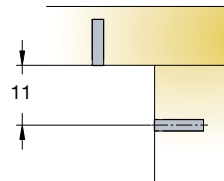
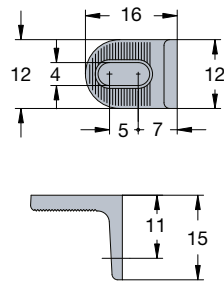

1000 Pcs

Made of zinc

Corner bracket (rock-in)

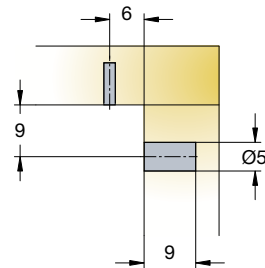
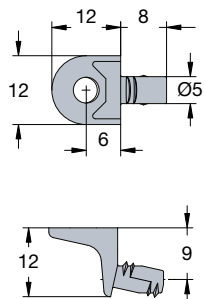

1000 Pcs

Made of zinc

Item number

02111 →

847

885

02110 →

847





885

02133 →

885

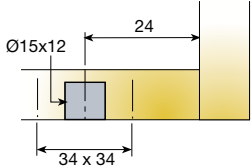
Adjustable Cabinet Legs

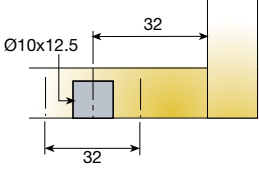
Leg Top Fixes

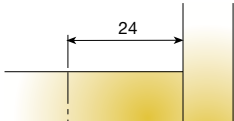
			Technical and mounting details	Item number	Black
Rivet fix	Regular		 	02560 →	835
	Heavy duty			*02630 →	835
				<i>* American market only</i>	
Socket fix (knock in)			 	02558 →	835
Socket fix (screw on)			 	02559 →	835

 200 Pcs

Made of plastic

 200 Pcs



Made of plastic

 200 Pcs

Made of plastic

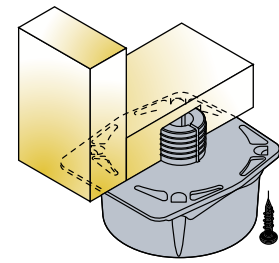
- Lip provides additional support to end panel and gives extra strength
- The side fix has twin dowel mounting for positive location
- Rivet fix design gives quick fastening of socket
- Choice of dowel or screw on sockets
- Invert second clip for corner plinth fixing



		A	D	B1	Item number	Black
Technical and mounting details		Drilling diameter	Drilling depth	Drilling distance		
Leg top  100 Pcs Made of plastic	(4 screws) screw on	3	6	64 x 64	02575 →	835
	(4 dowels + lip) dowel/lip	10	12.5	64 x 64	02582 →	835
	(4 screws + lip) screw/lip	3	6	64 x 64	02579 →	835
	2 dowels/2 screws	10/3	12.5/6	64 x 64	*02669 →	835
	Screw on	3	6	64 x 64	*02671 →	835
	Dowels	10	12.5	64 x 64	*02672 →	835
	* Asian market only When using leg top, you must use foot with 01373 clip → see page 3. 8					
Rivet fix/skid  200 Pcs Made of plastic					02663 →	835
Rivet fix/ no rivet  200 Pcs Made of plastic					*02642 →	835
* Asian market only						

Adjustable Cabinet Leg Range

Adjustable Leg, Extension and Foot

- Legs are supplied assembled at a pre-set height
- Wide adjustment range to fit all common plinth heights
- Jacking point adjustment feature
- Simple push on design to sockets

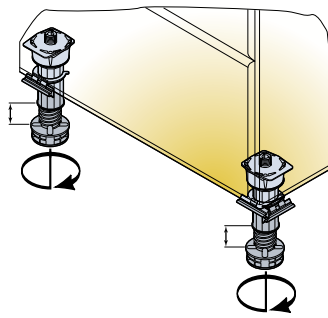

Technical and mounting details

Adjustable leg

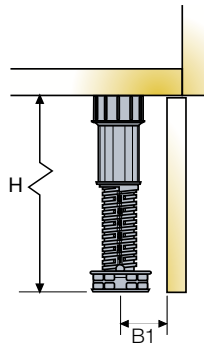

Big foot

Big foot

B1	H	Item number	Black
Drilling distance	Fitting height adjustment		
24	60-90	02570 →	835
24	92-152	02549 →	835
24	92.5-150	*02666 →	835
24	92-150	*02648 →	835
24	125-185	*02653 →	835
38	92-150	*02699 →	835
38	125-185	*02706 →	835

* Asian market only

100 Pcs (02570)
200 Pcs

Made of plastic

Leg extension

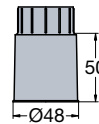

200 Pcs

Made of plastic

02571 → 835

Fixed foot

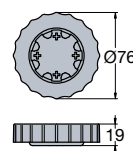

200 Pcs

Made of plastic

02569 → 835

***02574** → 835

* American market only

Adjustable Cabinet Leg Range

Plinth Clips and Fox Clip

- Spring design eliminates the need for drilling and fits into any position on plinth
- The screw in version can sit in variable plinth positions
- When taking plinth around the corner, the fitting is reversible.

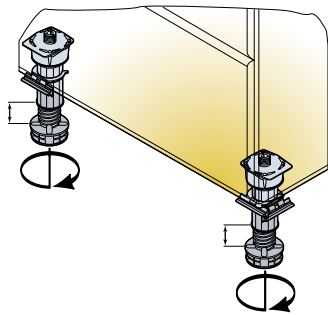

Technical and mounting details

Fox clip

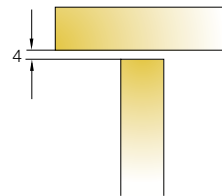

 1000 Pcs

Made of plastic

Plinth clip 38 screw

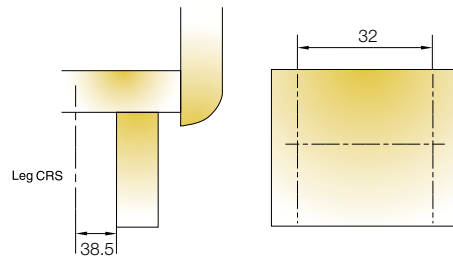

 500 Pcs

Made of plastic

Plinth clip 24 knock on

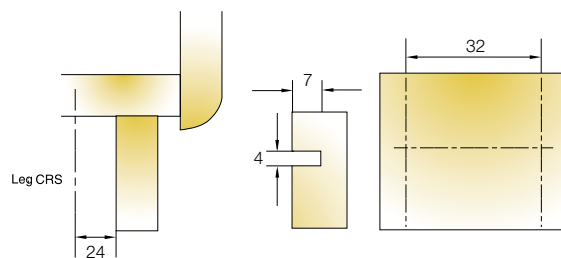

 600 Pcs

Made of plastic

Plinth clip 24 screw on

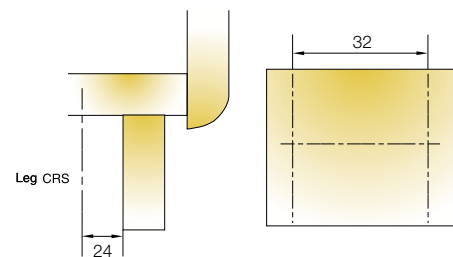

 600 Pcs

Made of plastic

Item number

01373 →

Natural

846

Black

835

02578 →

835

*02710 →

835

* Asian market only

02523 →

835

02634 →

835

Drawer Solutions

Drawer Front Adjuster (DFA)

- Multi-direction adjustment
- Locking screw to fasten
- Independent of drawer system
- One piece housing

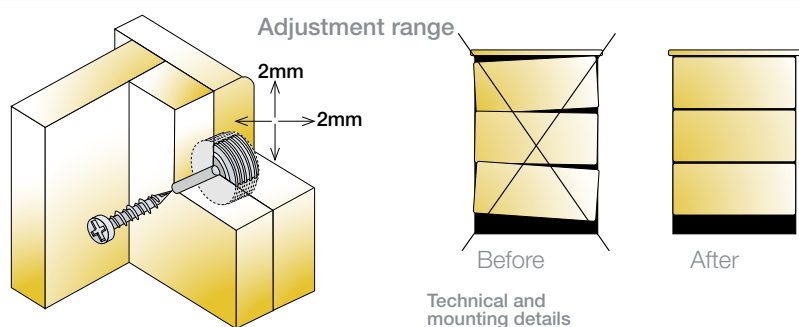

DFA housing

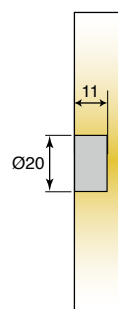

 2500 Pcs

Made of plastic

DFA housing

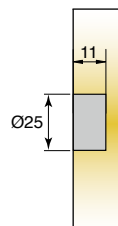
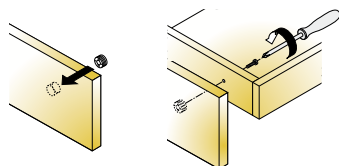

 2500 Pcs

Made of zinc, plastic

Item number	Dark brown	Black	Nickel	White
-------------	------------	-------	--------	-------

06308 →	831			877
---------	-----	--	--	-----

*06310 →	831			877
----------	-----	--	--	-----

*06309 →	831			877
----------	-----	--	--	-----

*00033 →			847	
----------	--	--	-----	--

*American market only
*06309 does not include screw

Concealed Hinges

Concealed Hinges

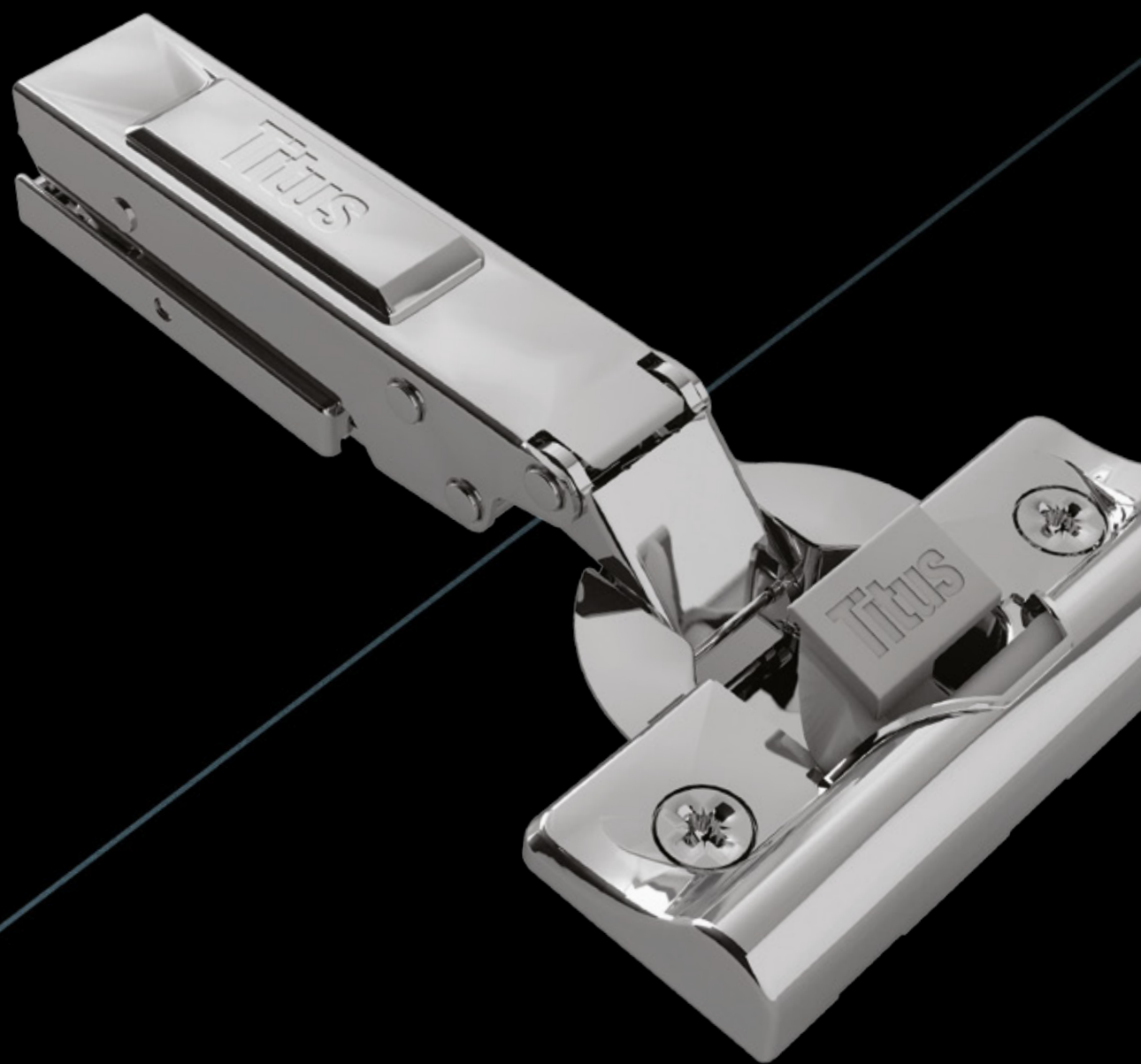

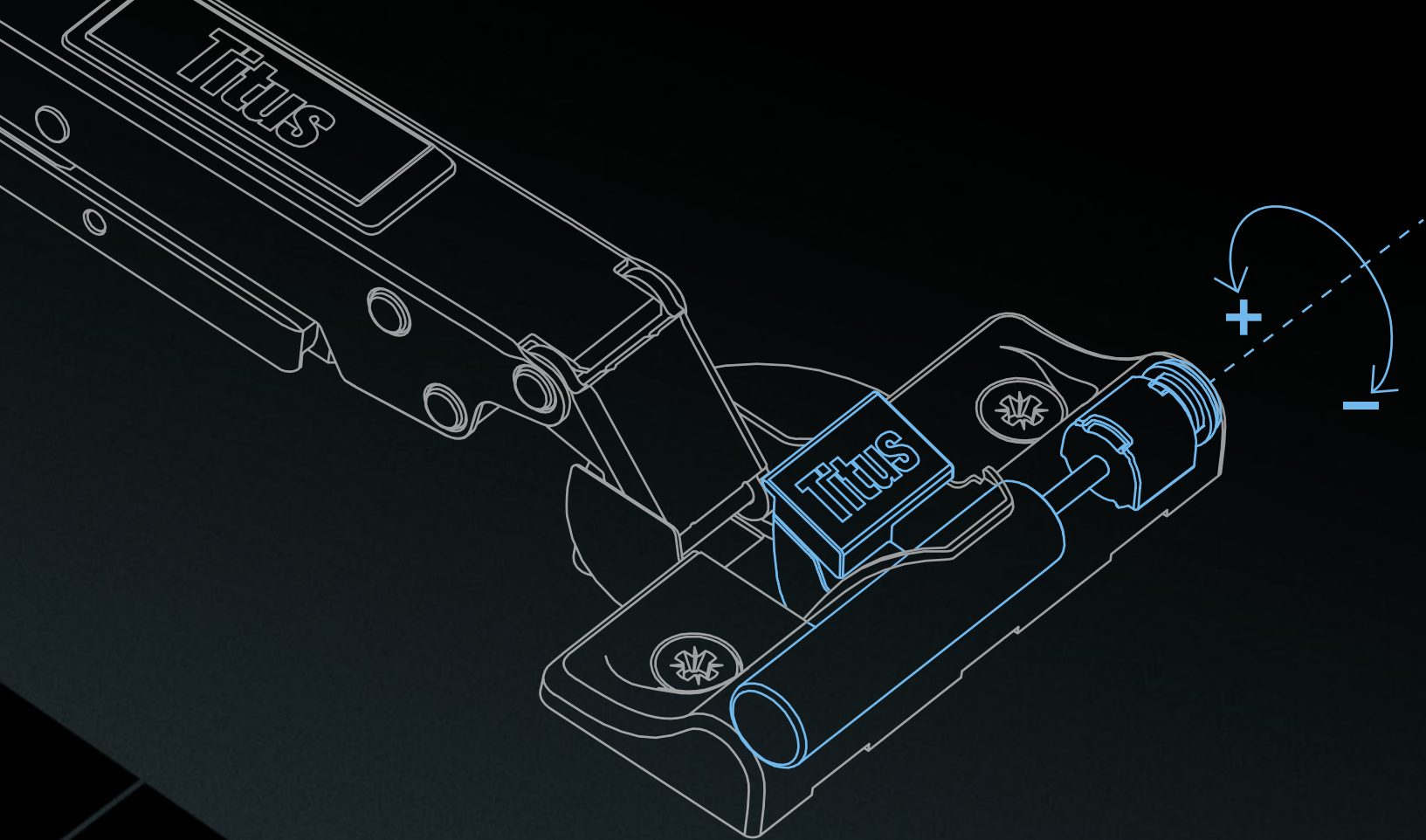

ConfidentClose

The hinge is designed to provide consumer preferred way of soft closing action.

- Fast closing
- Late start of deceleration action
- Quiet landing with SoftTouch

Based on independent consumer researches.

One-for-All

- Damping on the hinge cup
- Damper, positioned transversal to the hinge allows for easy introduction of various hinge versions
- Damped and non-damped version on one mounting plate platform

Adjustable Damping

Flexibility to tune performance to wide range of applications

- Consistent performance over a wide range of doors of different sizes and weights
- Easy accessible button for intuitive and quick adjustment

Titus Damper Inside

- Efficient damping at any closing speed
- Reliable closing
- Damping force consistency

Concealed Hinges

A Comprehensive Range

T-type hinge



Titus hinge for quick furniture assembly and consistent performance on wide range of doors

- 3Way snap-on mounting
- Highly tolerant
- Adjustable damping
- Shallow hinge cup
- Touch opening for handleless furniture

S-type hinge



Simple and quick snap-on mounting system

- Easy assembly and disassembly
- ConfidentClose
- Touch opening for handleless furniture

B-type hinge

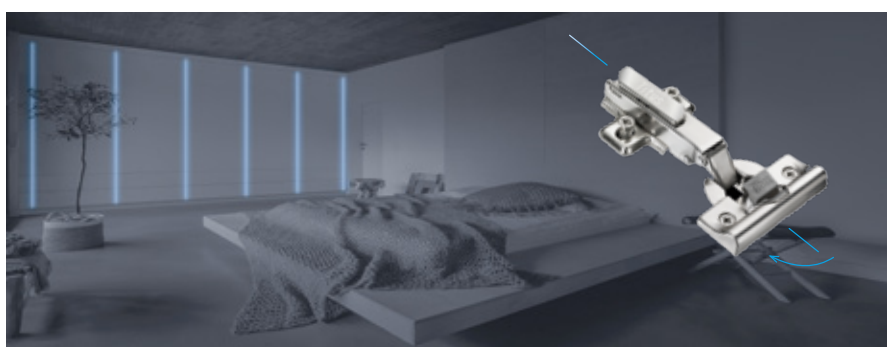

Reliable slide-on mounting system

- ConfidentClose
- Reliable door closing

Opening angle	Door thickness	Cranking	Door tab K	Mounting mode	Mounting plate type	Mounting plate height	Soft closing options	Page
95° 110° 120° 170°	15-34mm 15-26mm	0mm 5mm 9mm 17mm angled	3-9mm 3-6mm	'3Way' snap-on	cruciform linear for face frame	0mm 1mm 2mm 3mm 4mm	Damping integrated in the hinge cup Glissando add-on or stand-alone damping solutions	2.27
110° 170°	16-24mm	0mm 9mm 15mm angled	3-5mm 3-12mm	snap-on	cruciform for face frame	0mm 1mm 2mm 3mm 6mm 9mm 18mm	Damping integrated in the hinge cup Glissando add-on or stand-alone damping solutions	2.85
110° 170°	16-24mm	0mm 9mm 15mm angled	3-5mm 3-12mm	slide-on	cruciform	0mm 1mm 2mm 3mm 4mm 5mm 6mm 9mm 18mm	Damping integrated in the hinge cup Glissando add-on or stand-alone damping solutions	2.133

Concealed Hinges

Product Guide

	Cranking	Opening angle	Cup type	Page
T-type				
T-type-i 110	0mm	110°	for wood door	2.29
	5mm	110°	for wood door	2.29
	9mm	110°	for wood door	2.31
	17mm	110°	for wood door	2.31
T-type-i 110/15°	15°, 9mm	110°	for wood door	2.33
T-type-i 110/30°	30°, 9mm	110°	for wood door	2.35
T-type-i 110/45°	45°, 9mm	110°	for wood door	2.37
	45°, 17mm	110°	for wood door	2.39
	45° , 23 mm	110°	for wood door	2.41
T-type-i 110/90° for blind corner	90°, 17mm	110°	for wood door	2.43
T-type-i 120	0mm	120°	for wood door	2.49
T-type-i 95	0mm	95°	for wood door	2.47
	5mm	95°	for wood door	2.47
	9mm	95°	for wood door	2.49
	17mm	95°	for wood door	2.49
T-type 110	0mm	110°	for wood door	2.51
	5mm	110°	for wood door	2.51
	9mm	110°	for wood door	2.53
	17mm	110°	for wood door	2.53
T-type 110/15°	15°, 9mm	110°	for wood door	2.55
T-type 110/30°	30°, 9mm	110°	for wood door	2.57
T-type 110/45°	45°, 9mm	110°	for wood door	2.59
	45°, 17mm	110°	for wood door	2.61
T-type 110/90° for blind corner	90°, 17mm	110°	for wood door	2.63
T-type 120	0mm	120°	for wood door	2.33

	Cranking	Opening angle	Cup type	Page
T-type				
T-type 95	0mm	95°	for wood door	2.67
	5mm	95°	for wood door	2.67
	9mm	95°	for wood door	2.69
	17mm	95°	for wood door	2.69
T-type 110 PushOpen Hinge	0mm	110°	for wood door	2.71
	5mm	110°	for wood door	2.71
	9mm	110°	for wood door	2.73
T-type 170	0mm	170°	for wood door	2.75
	5mm	170°	for wood door	2.77
	9mm	170°	for wood door	2.77
T-type for pie-cut corner cabinet			for wood door	2.79
T-type mounting plates				2.81

	Cranking	Opening angle	Cup type	Page
S-type				
S-type-i3 110	0mm	110°	for wood door	2.87
	9mm	110°	for wood door	2.87
	15mm	110°	for wood door	2.87
S-type-i3 110/15°	15°, 9mm	110°	for wood door	2.89
S-type-i3 110/24°	24°, 9mm	110°	for wood door	2.91
S-type-i3 110/30°	30°, 9mm	110°	for wood door	2.93
S-type-i3 110/45°	45°, 9mm	110°	for wood door	2.95
	45°, 18mm	110°	for wood door	2.97
S-type-i3 110/90°	90°, 18mm	110°	for wood door	2.99
S-type 110	0mm	110°	for wood door	2.101
	9mm	110°	for wood door	2.101
	15mm	110°	for wood door	2.101
S-type 110/-15°	-15°, 9mm	110°	for wood door	2.103
S-type 110/15°	15°, 9mm	110°	for wood door	2.105
S-type 110/24°	24°, 9mm	110°	for wood door	2.107
S-type 110/30°	30°, 9mm	110°	for wood door	2.109
S-type 110/45°	45°, 9mm	110°	for wood door	2.111
	45°, 18mm	110°	for wood door	2.113
S-type 110/90°	90°, 18mm	110°	for wood door	2.115
S-type 110 AL	0mm	110°	for aluminium frame door	2.117
	9mm	110°	for aluminium frame door	2.117
	15mm	110°	for aluminium frame door	2.117
S-type 110 PushOpen Hinge	0mm	110°	for wood door	2.119

	Cranking	Opening angle	Cup type	Page
S-type				
S-type 170	0mm	170°	for wood door	2.121
	9mm	170°	for wood door	2.123
S-type for pie-cut corner cabinet			for wood door	2.125
S-type mounting plates				2.127

	Cranking	Opening angle	Cup type	Page
B-type				
B-type-i3 110	0mm	110°	for wood door	2.135
	9mm	110°	for wood door	2.135
	15mm	110°	for wood door	2.135
B-type-i3 110/30°	30°, 9mm	110°	for wood door	2.137
B-type-i3 110/45°	45°, 9mm	110°	for wood door	2.139
	45°, 18mm	110°	for wood door	2.141
B-type-i3 95°/90°	90°, 18mm	95°	for wood door	2.143
B-type 110	0mm	110°	for wood door	2.145
	9mm	110°	for wood door	2.145
	15mm	110°	for wood door	2.145
B-type 110/30°	30°, 9mm	95°	for wood door	2.147
B-type 110/45°	45°, 9mm	110°	for wood door	2.149
	45°, 18mm	110°	for wood door	2.151
B-type 110°/90°	90°, 0mm	110°	for wood door	2.153
	90°, 18mm	95°	for wood door	2.153
B-type 110 AL	0mm	110°	for aluminium frame door	2.155
	9mm	110°	for aluminium frame door	2.155
	15mm	110°	for aluminium frame door	2.155
B-type 110 AL (Glissando AL ready)	0mm	110°	for aluminium frame door	2.157
	9mm	110°	for aluminium frame door	2.157
	15mm	110°	for aluminium frame door	2.157
B-type 170	0mm	170°	for wood door	2.159
	9mm	170°	for wood door	2.161
B-type for pie-cut corner cabinet			for wood door	2.163
B-type flap door hinge	0mm	90°	for wood door	2.165
B-type mounting plates				2.167

	Opening angle	Cup type	Page
--	---------------	----------	------

Other Hinges

Wide angle hinge and mounting plate	270°	for wood door	2.171
Refrigerator cabinet door hinge	100°	for wood door	2.173

Accessories

Hinge Angle Restrictor			2.175
Cover caps			2.177

Glissando Soft Closing Systems for Hinges

Glissando TL3			2.189
Glissando TT			2.189
Glissando TL 170			2.191
Glissando AL			2.193
Glissando CR			2.195

PushOpen Solutions

Push Latch			2.199
PushOpen Short			2.201
PushOpen Long			2.203

Concealed Hinges

Door Overlay

How to Achieve the Desired Door Overlay?

By choosing the hinge of appropriate cranking

Concealed hinges with specific hinge arms are available for different door overlays. The most common overlays are:

■ Cabinet side
■ Door

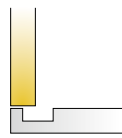

- 1. Full overlay**
Use a hinge with 0mm cranking

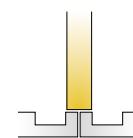

- 2. Partial overlay for double doors**
Use a hinge with 5mm or 9mm cranking



- 3. Inset door**
Use a hinge with 15mm or 17mm cranking

By choosing the mounting plates of appropriate thickness

To achieve the desired overlay (x) while using a determined drilling distance (K), a mounting plate of appropriate

thickness (D) must be chosen from the enclosed table or calculated with given formula.

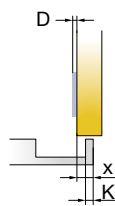

x	4	5	6	7	8	9
3	3	2	1	0		
K 4		3	2	1	0	
5			3	2	1	0
D						

$$D = 4 + K - x$$

By choosing the appropriate drilling distance K

To achieve the desired door overlay (x) while using a determined mounting plate thickness (D), an appropriate drilling distance K must be chosen.

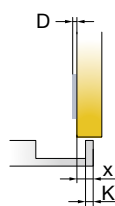

x	4	5	6	7	8	9
0				3	4	5
1			3	4	5	
D 2				4	5	
3	3	4	5			
K						

Through side adjustment

Side adjustment is made by rotating the appropriate screw on the hinge arm.

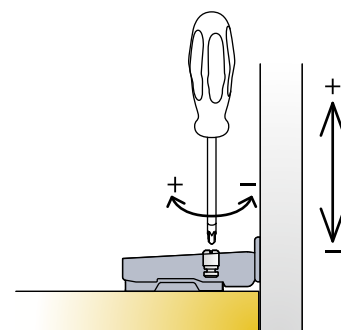
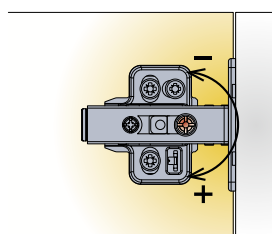

Door clearance and gap

Door clearance ($F \geq F_{min}$) and gap (Z) represent the minimal necessary space needed for the correct opening and closing of the door. The minimal required values depend on the cup drilling distance (K), door thickness (V)

and the type of hinge. The minimum clearance scale can be found on product pages → see Door clearance chart. When using hinges with partial overlay the door clearance must be twice as large ($F \geq 2F_{min}$).

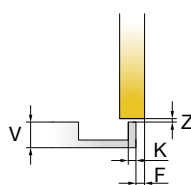

V	16	17	18	19	20	21	22
3	0.3	0.5	0.7	1.0	1.3	1.7	2.5
K 4	0.3	0.5	0.7	0.9	1.2	1.6	2.1
5	0.3	0.5	0.7	0.9	1.2	1.5	2.0 F_{min}

Gap $Z_{min}=0$

Concealed Hinges

Hinge Cup Types

How to Mount the Hinge on the Door?

There are cup type symbols listed on product pages beside item numbers. Below you can find their explanation.

No pre-mounting

The hinge is fixed on the door with two screws. 3mm pilot holes recommended.

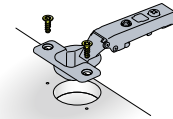

EasyFix

Quarter turn fixing for 8mm holes (interaxis 45/9.5) or 10mm holes (interaxis 48/6 and 52/5.5).

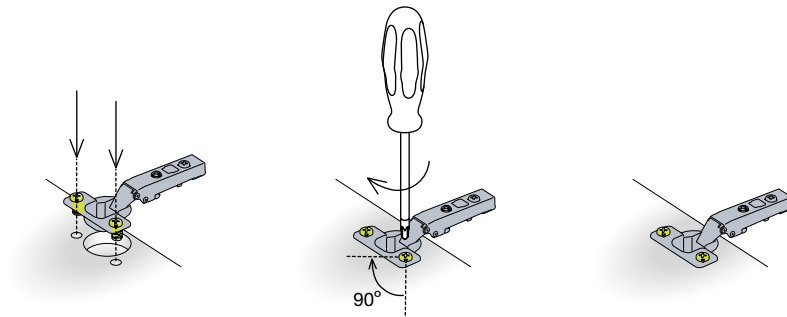

Machine insertion ready hinge cup

Pre-mounted dowels suitable for machine insertion into 8mm holes (interaxis 45/9.5) or 10mm holes (interaxis 48/6 and 52/5.5)

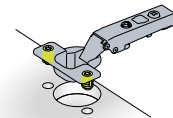

FastFix

Pre-mounted expanding dowels with triple-start screw for fast fixing, suitable for 8mm holes.

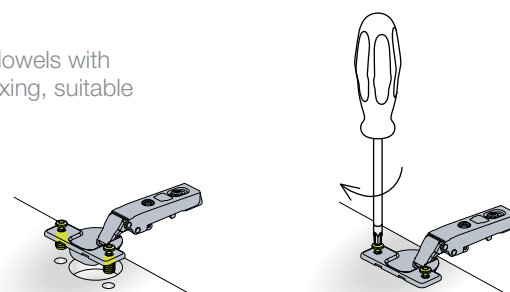

**Aluminium frame
screw-on hinge cup**

The hinge is fixed onto a specific drilling on the aluminium frame.

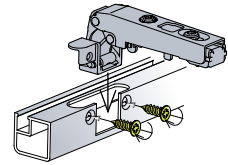

Concealed Hinges









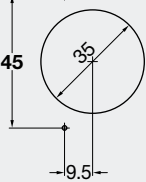
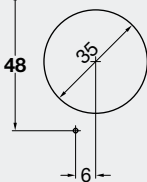
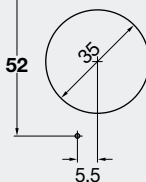

Boring Details

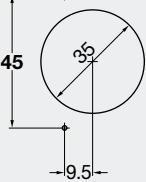
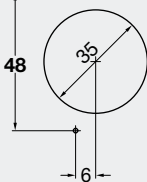
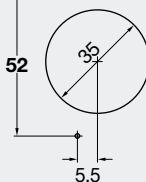
Drilling Patterns for Hinge Cup

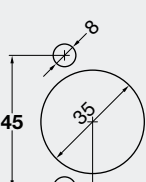
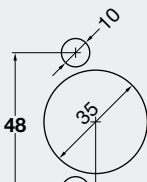
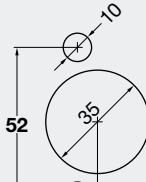
Interaxis 45mm, 48mm and 52mm*

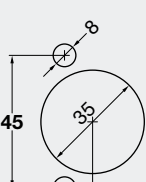
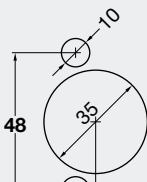
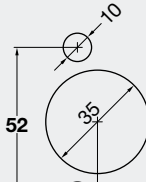
- T-type
- S-type
- B-type

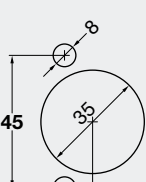
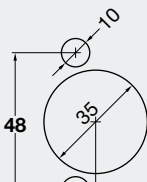
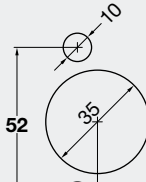
*Available on special request → see page 0.3

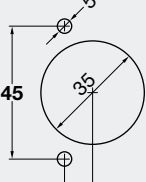
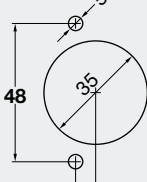
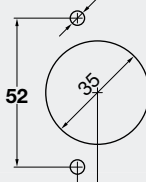
	Interaxis 45mm	Interaxis 48mm	Interaxis 52mm*
Hinge cup type	Drilling pattern	Drilling pattern	Drilling pattern
 Screw-on ready			
 Pre-mounted Ø4.5mm screws			
 Machine insertion ready			
 FastFix			
 EasyFix			
 Pre-mounted euro screws			

Interaxis is the distance between two holes center for fixing screws on the hinge cup.

Concealed Hinges

Mounting Plate Type

How to Fix the Mounting Plate on the Cabinet Side?

There are mounting plate type symbols listed on product pages beside item numbers. Below you can find their explanation.



Chipboard screw-on ready

Mounting plate is fixed with two chipboard screws or equivalent. 3mm pilot holes recommended.

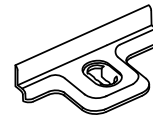

Euro screw ready

Fixing with 6.3mm euro screws into pre-drilled 5mm holes. To choose appropriate head and length for use with this mounting plate is recommended.

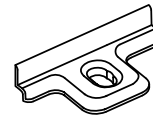

Machine insertion ready

Pre-mounted dowels for machine insertion into pre-drilled holes.

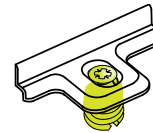

Pre-mounted euro screws

Euro screws for 5mm holes are pre-mounted on the mounting plate. Available lengths: 11mm, 13mm and 15mm

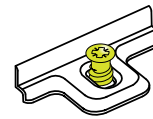

Pre-mounted expanding dowels

Pre-mounted expanding dowels for 5mm holes. Available lengths: 7.5mm and 10.5mm

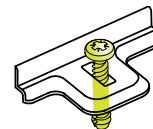

Pre-mounted Ø4.5mm screws

Mounting plate is fixed with two pre-mounted chipboard screws. 3mm pilot holes recommended.

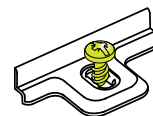

Concealed Hinges

Hinge-to-plate Mounting

How to Assemble the Hinge and the Mounting Plate?

T-type 3Way snap-on

3Way snap-on mounting for intuitive hinge-to-plate assembly in three directions:

- from the hinge arm front
- from the hinge arm rear
- from the top

front assembly

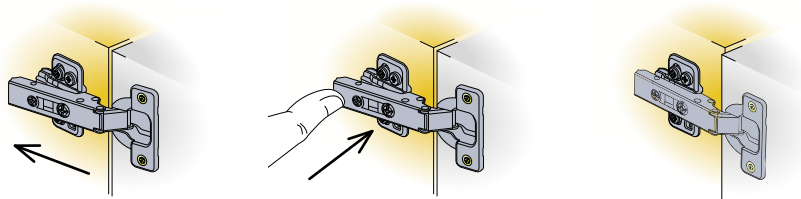

rear assembly

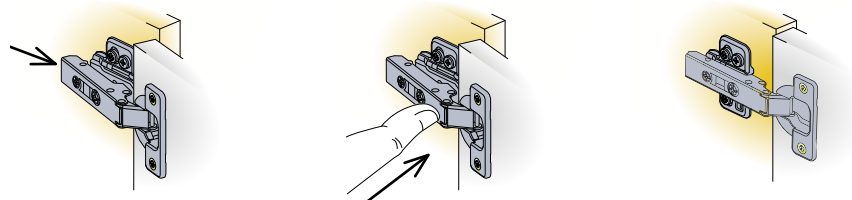

top assembly



disassembly:
for disassembly press rear
lever on the hinge arm.

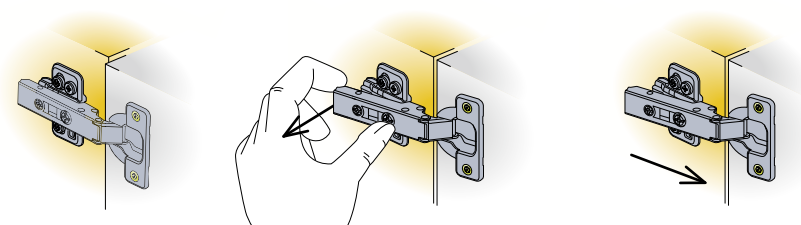

S-type snap-on

Door is assembled on the cabinet side simply by positioning the two hooks under the hinge arm on the outer part of the mounting plate and pressing gently on the rear part of the hinge arm.

For disassembly press the rear button on the hinge arm.

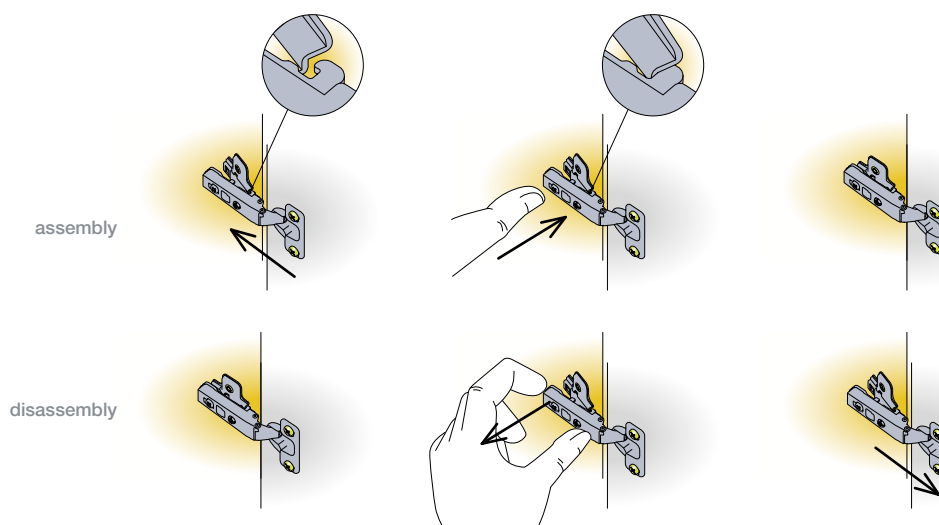

B-type slide-on

Hinge is assembled by sliding the hinge arm over the mounting plate. The hinge adjustment screw must fit into the groove on the mounting plate.

After adjusting the door depth, the mounting procedure is finished by tightening the fixing screw.



Key-hole

- Wide angle hinge
- Refrigerator cabinet door hinge

Hinge is assembled on the mounting plate by inserting the fixing screw on the appropriate hole on the hinge arm.

After adjusting the door depth, the mounting procedure is finished by tightening the fixing screw.

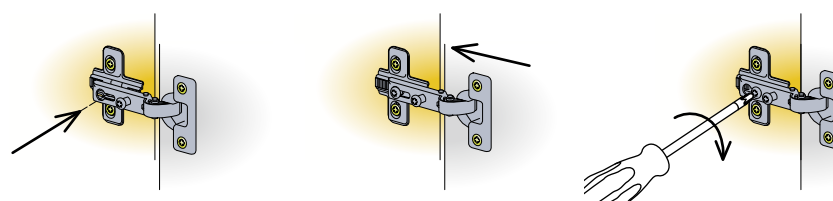

Concealed Hinges

Loadings

How Many Hinges per Door?

Check the enclosed recommendation for the number of recommended hinges per door by considering door height and weight.

Recommendation: Use the appropriate number of hinges, not exceeding door height and weight as shown below.

Concealed hinges with Ø 35mm hinge cup diameter

Standard hinges

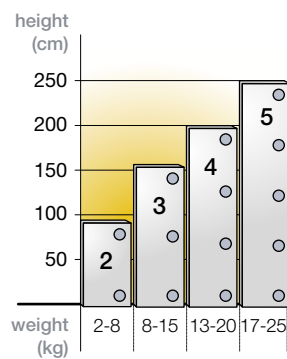

T-type

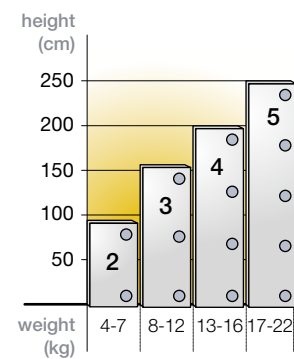

S-type
B-type

Hinges with integrated damping

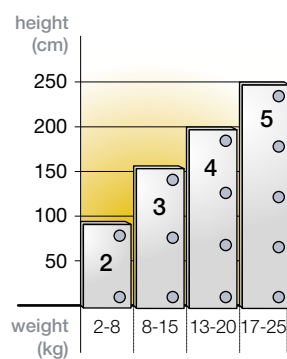

T-type-i

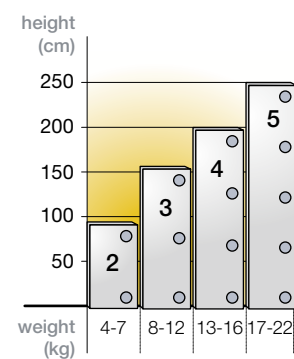

S-type-i3
B-type-i3

Hinges with integrated damping can be combined with non-damped hinges from standard hinge range. A trial mounting is always recommended.

Concealed Hinges

Adjustment



Adjustment range can be found on the product pages.

Side Adjustment

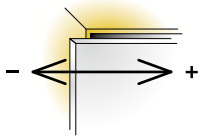

Side adjustment aligns the door with the side of the cabinet.

By rotating the adjustment screw

- T-type
- S-type
- B-type

Side adjustment is made by rotating the screw on the hinge arm.

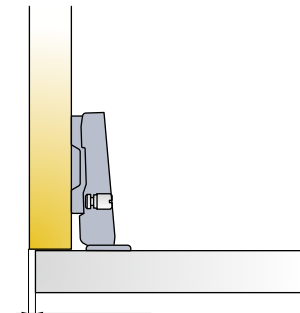
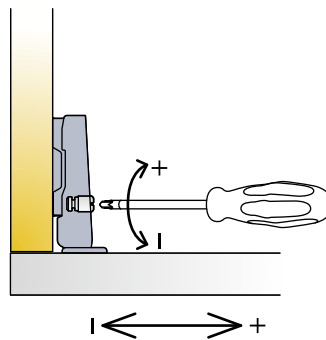
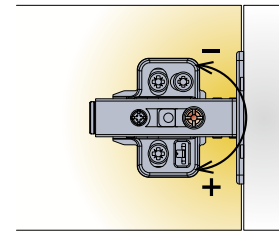

Adjustment range

By temporarily loosening the fixing screw

- Wide angle hinge 270°
- Refrigerator cabinet hinge

For the side adjustment:
 1. Release the fixing screw
 2. Make the necessary adjustment by rotating the appropriate screw
 3. Tighten the fixing screw
 Without releasing the fixing screw no side adjustment is possible.

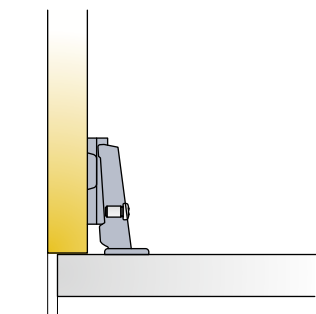
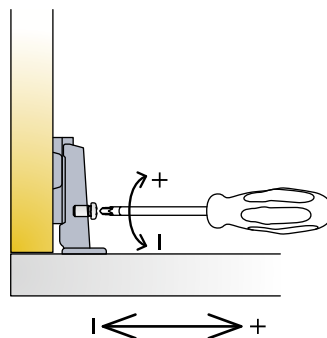

Adjustment range

Concealed Hinges

Adjustment

Height Adjustment

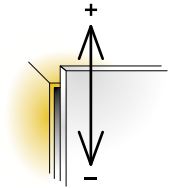

Height adjustment is necessary to achieve optimal vertical door position.

By rotating the cam adjuster

Height adjustment is made by rotating the cam adjuster on the mounting plate.

T-type with cam adjustable cruciform mounting plate

S-type with cam adjustable cruciform mounting plate

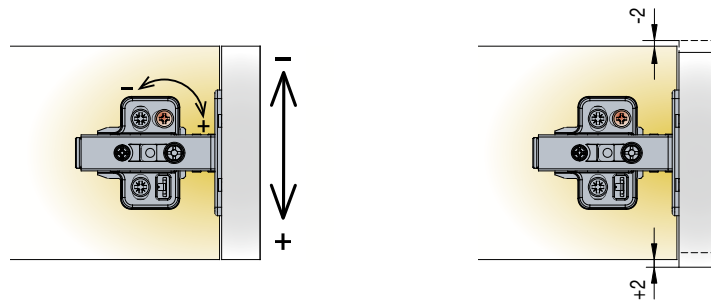

T-type with cam adjustable horizontal mounting plate

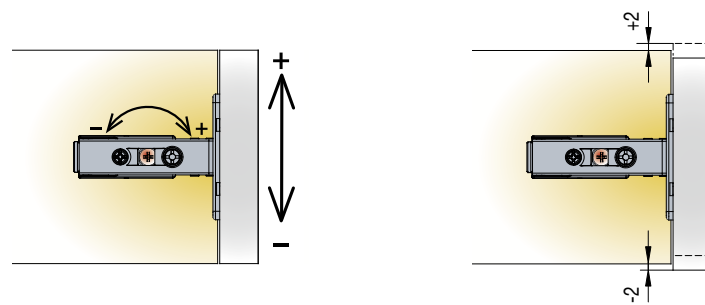

By releasing the fixing screws

For height adjustment the two mounting plate fixing screws have to be temporarily released while making the manual adjustment.

- T-type, S-type and B-type with cruciform mounting plate
- Wide angle hinge 270°
- Refrigerator cabinet hinge

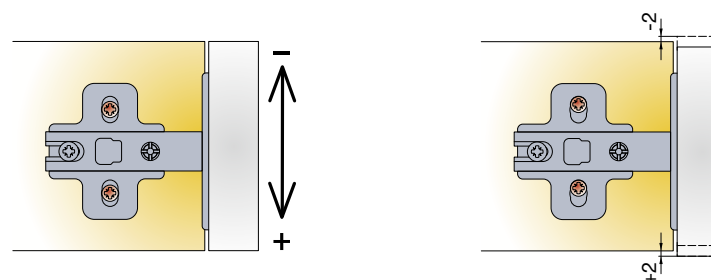

Concealed Hinges

Adjustment

Depth Adjustment

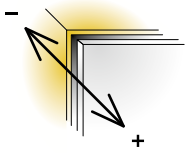

The system enables easy adjustment of the gap between door and cabinet.

By rotating the cam adjuster

Rotate the cam adjuster on the hinge arm.

- T-type

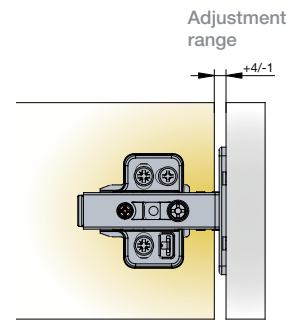
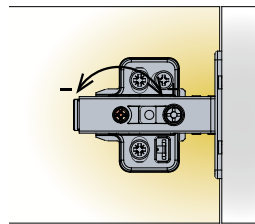

By releasing the fixing or adjustment screw

- S-type
- B-type

The depth adjustment is made by temporarily releasing the adjustment screw (S-type) or fixing screw (B-type). After the adjustment is made the screw has to be re-tightened.

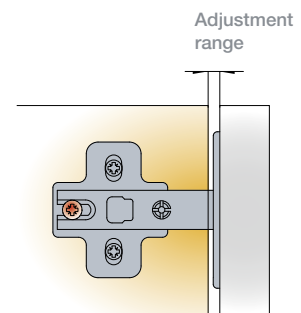
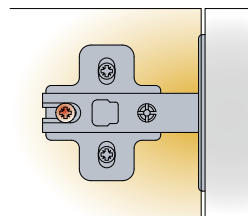

Concealed Hinges

Damping Adjustment

Damping Adjustment

T-type-i

The damping action can be adjusted to fit different door weights and sizes which enables optimal door functioning.

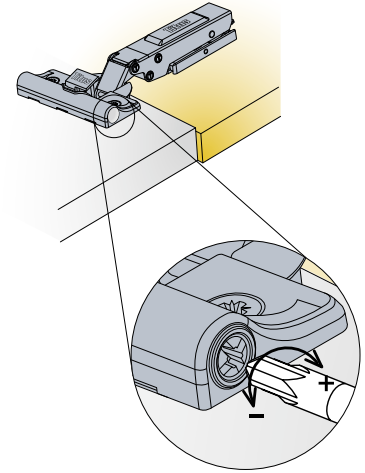

Damping is factory pre-set to the medium damping value. Turn towards '+' to increase and '-' to decrease the damping.

Key Design Choices

ConfidentClose

The hinge is designed to provide consumer preferred way of soft closing action.

Based on results of Titus researches made in UK, Germany and Slovenia

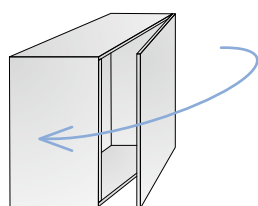

Fast closing

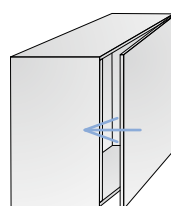

Late start of deceleration action

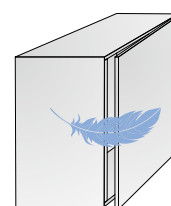

Quiet landing with SoftTouch

One-for-all efficiency principle

Damping on the hinge cup
 Damper, positioned transversal to the hinge cup allows for easy introduction of hinge versions

Damped and non-damped version on one mounting plate platform

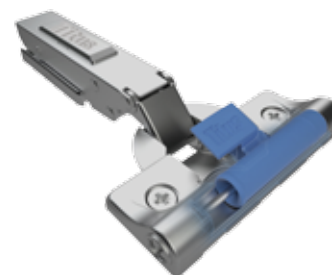

Adjustable damping

Flexibility to tune performance for all applications

- Consistent performance over a wide range of doors of different sizes and weights
- Easy accessible adjustment button for intuitive and quick adjustment

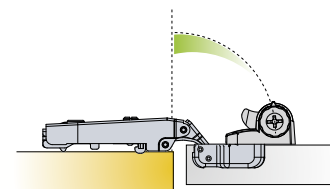

Adjustable damping zone and force

Titus Damper Inside

- Efficient damping at any closing speed
- Reliable closing
- Damping force consistency



T-type Hinges

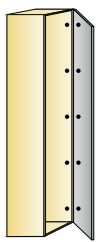

Easy door installation even in cases of 3-5 hinges per door

- Easy and quick assembly and disassembly

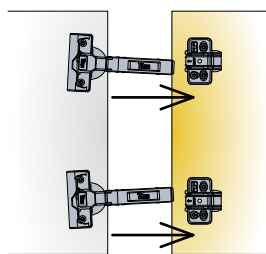

Highly tolerant

- Efficient performance in edge value of tolerances
- Reliable door closing in case of accidental misalignment
- ConfidentClose assured

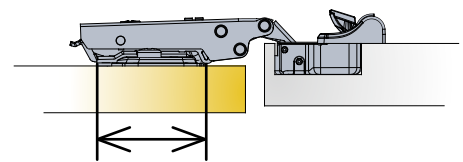

Rigidity

- Rigid hinge-to-plate attachment assures door stability
- Tight hinge-to-plate joint improves hinge stability and reduces door sag
- Smooth performance

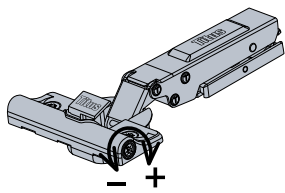
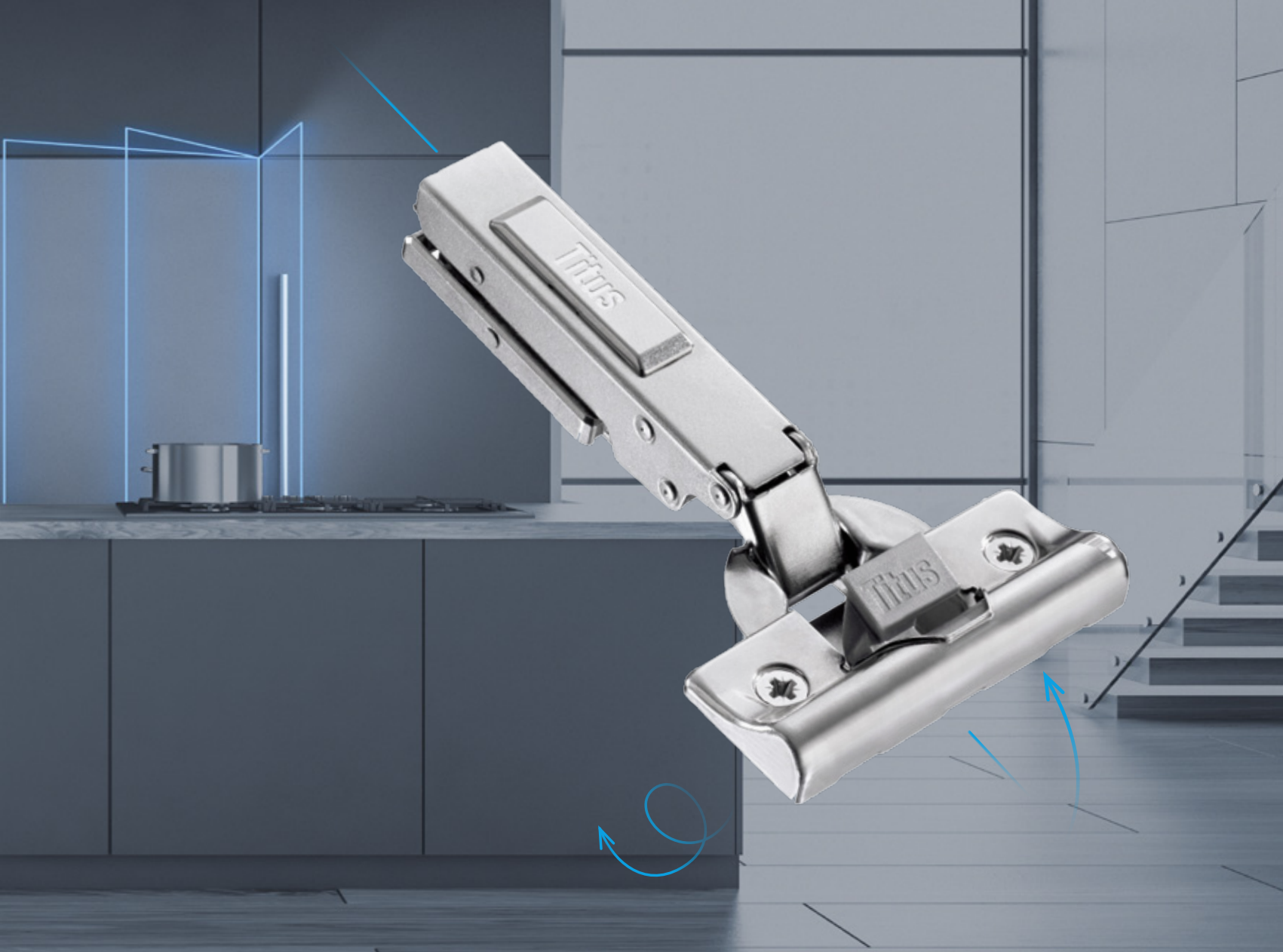

Adjustable damping

- Consistent performance on doors of different dimensions and weights
- Intuitive adjustment



Titus Damper Inside

- Titus proprietary multi-purpose damping technology
- Reliable and consistent life-long damping



Proven Glissando concept

- Damper is positioned transversal on the hinge cup
- Reliable performance

T-type-i 110

For wood doors

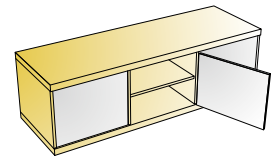
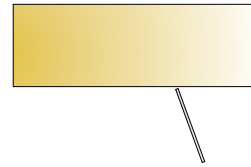
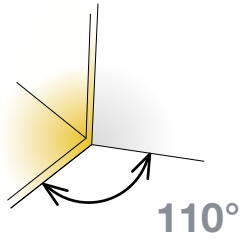

- Opening angle
- Drilling diameter for hinge cup
- Drilling depth
- Hinge on plate mounting system

110°
35mm
12mm
3Way snap-on



Technical details

Cup type	Interaxis 45mm	Interaxis 48mm
Item number		

Cranking
0mm

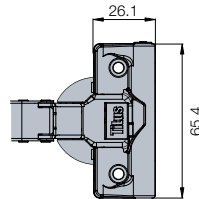
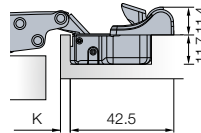
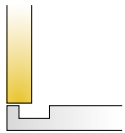

150 Pcs Made of steel

	701-0AT0-054	701-0AS0-054
	701-0AT1-054	701-0AS1-054
	701-0AT4-054	701-0AS4-054

Drilling patterns for hinge cups → see page 2.17

Cranking
5mm

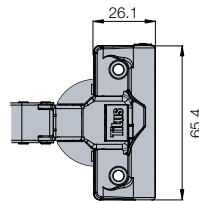
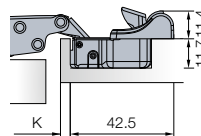
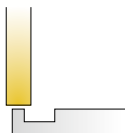

150 Pcs Made of steel

	701-0BT0-054	701-0BS0-054
	701-0BT1-054	701-0BS1-054
	701-0BT4-054	701-0BS4-054

Drilling patterns for hinge cups → see page 2.17

Mounting plates



Cam adjustable cruciform mounting plate
→ see page 2.81



Cruciform mounting plate
→ see page 2.83



Cam adjustable linear mounting plate
→ see page 2.81



Face frame adapter plate
→ see page 2.83

Hinge cup screws If not pre-mounted

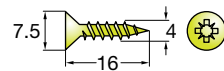

820-6328-050

10000 Pcs

Accessories



Cover caps for hinge arm
→ see page 2.177



Hinge angle restrictor
→ see page 2.175

Legend of hinge cup symbols

Screw-on ready
← screws

Machine insertion ready

EasyFix system

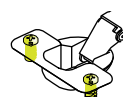
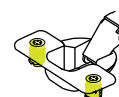

Damping adjustment

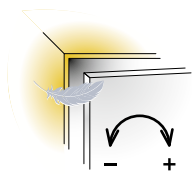

Door adjustment

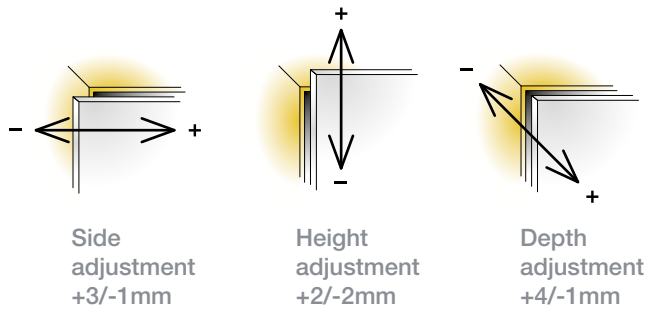

For further explanation → see page 2.25

For further explanation → see pages 2.22-2.24

Mounting details

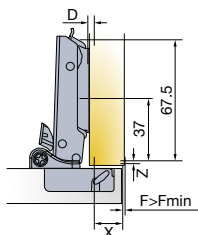
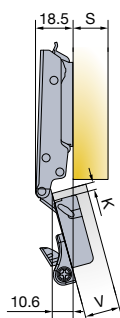

Mounting plate drilling distance

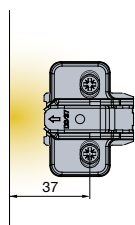

Mounting plate thickness table

For further explanation → see page 2.13

X	13	14	15	16	17	18	19
3	3	2	1	0			
4	4	3	2	1	0		
K							
5		4	3	2	1	0	
6			4	3	2	1	0
							D

$D=13+K-X$

Drawings show application on D=0mm mounting plate

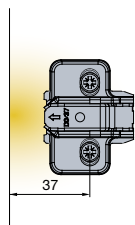
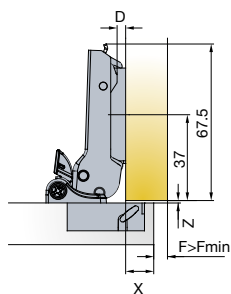
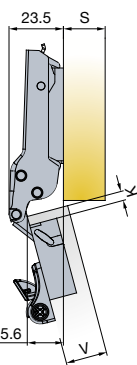

X	8	9	10	11	12	13	14
3	3	2	1	0			
4	4	3	2	1	0		
K							
5		4	3	2	1	0	
6			4	3	2	1	0
							D

$D=8+K-X$

Drawings show application on D=0mm mounting plate

Touch opening



PushOpen Solutions
→ see pages 2.199-2.204

Door clearance at R=1mm

For further explanation → see page 2.14

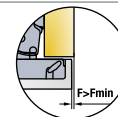

V	16	17	18	19	20	21	22	23	24	25	26
3	0.5	0.7	0.8	1	1.2	1.5	1.7	2.1	2.8	4.1	5.5
4	0.4	0.7	0.8	1	1.2	1.5	1.7	2.1	2.3	3.1	4.5
K											
5	0.4	0.6	0.7	0.9	1.1	1.4	1.6	2	2.2	2.6	3.5
6	0.4	0.6	0.7	0.9	1.1	1.4	1.6	2	2.2	2.6	2.9
											F _{MIN}

Gap Z_{MIN}=0

T-type-i 110

For wood doors

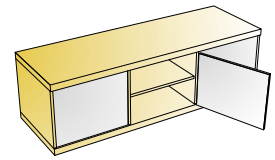
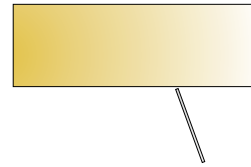
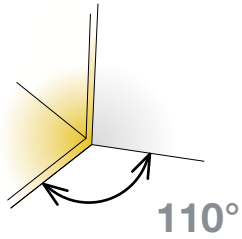

- Opening angle
- Drilling diameter for hinge cup
- Drilling depth
- Hinge on plate mounting system

110°
35mm
12mm
3Way snap-on



Technical details

Cup type	Interaxis 45mm	Interaxis 48mm
Item number		

Cranking
9mm

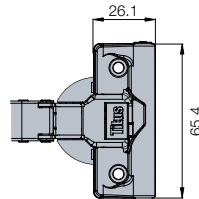
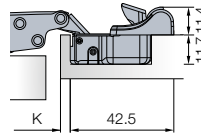
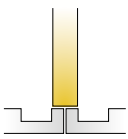

	701-OCT0-054	701-OCS0-054
	701-OCT1-054	701-OCS1-054
	701-OCT4-054	701-OCS4-054

Drilling patterns for hinge cups → see page 2.17

150 Pcs

Made of steel

Cranking
17mm

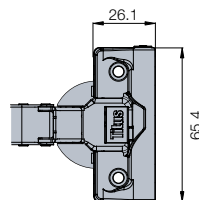
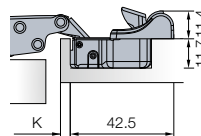
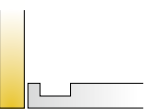

	701-ODT0-054	701-ODS0-054
	701-ODT1-054	701-ODS1-054
	701-ODT4-054	701-ODS4-054

Drilling patterns for hinge cups → see page 2.17

150 Pcs

Made of steel

Mounting plates



Cam adjustable cruciform mounting plate
→ see page 2.81



Cruciform mounting plate
→ see page 2.83



Cam adjustable linear mounting plate
→ see page 2.81



Face frame adapter plate
→ see page 2.83

Hinge cup screws

If not pre-mounted

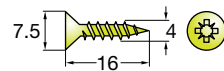

820-6328-050

10000 Pcs

Accessories



Cover caps for hinge arm
→ see page 2.177



Hinge angle restrictor
→ see page 2.175

Legend of hinge cup symbols

Screw-on ready
← screws

Machine insertion ready

EasyFix system

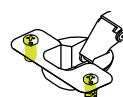
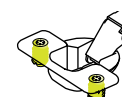

Damping adjustment

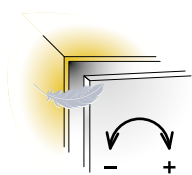

Door adjustment

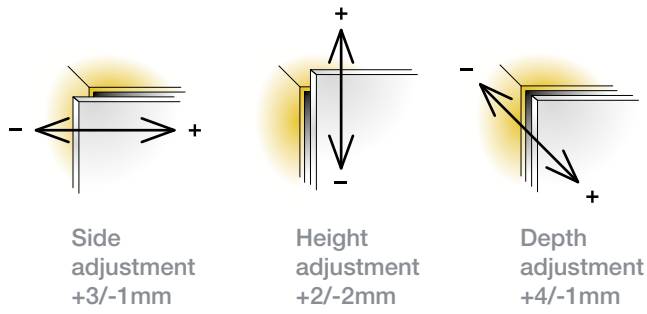

For further explanation → see page 2.25

For further explanation → see pages 2.22-2.24

Mounting details

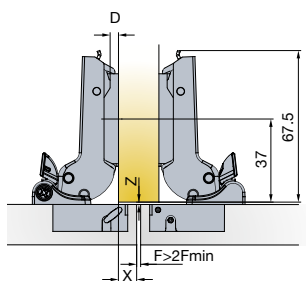
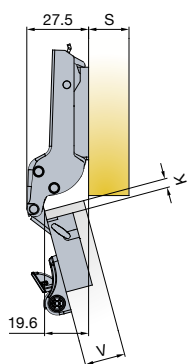

Mounting plate drilling distance

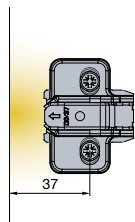

Mounting plate thickness table

For further explanation → see page 2.13

X	4	5	6	7	8	9	10
3	3	2	1	0			
4	4	3	2	1	0		
K							
5		4	3	2	1	0	
6			4	3	2	1	0
							D

$D=4+K-X$

Drawings show application on D=0mm mounting plate

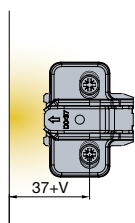
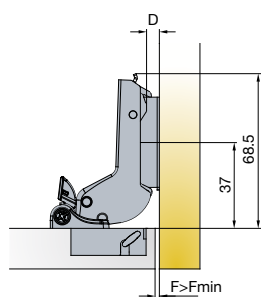
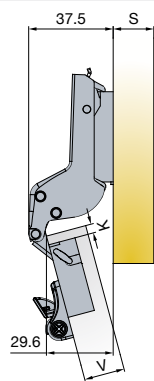

V	16	17	18	19	20	21	22	23	24
3	0	0	0	0	1	1	1	1	2
4	1	1	1	1	2	2	2	2	3
K									
5	2	2	2	2	3	3	3	3	4
6	3	3	3	3	4	4	4	4	
									D

$D=-4+K+F$

Drawings show application on D=2mm mounting plate

Touch opening



PushOpen Solutions
→ see pages 2.199-2.204

Door clearance at R=1mm

For further explanation → see page 2.14

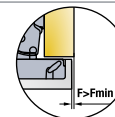

V	16	17	18	19	20	21	22	23	24	25	26
3	0.5	0.7	0.8	1	1.2	1.5	1.7	2.1	2.8	4.1	5.5
4	0.4	0.7	0.8	1	1.2	1.5	1.7	2.1	2.3	3.1	4.5
K											
5	0.4	0.6	0.7	0.9	1.1	1.4	1.6	2	2.2	2.6	3.5
6	0.4	0.6	0.7	0.9	1.1	1.4	1.6	2	2.2	2.6	2.9
											F _{MIN}

Gap Z_{MIN}=0

T-type-i 110/15°

15° angled application for wood doors

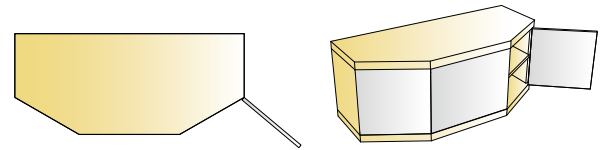
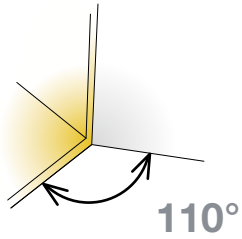

- Opening angle 110°
- Drilling diameter for hinge cup 35mm
- Drilling depth 12mm
- Hinge on plate mounting system 3Way snap-on



Technical details

Cup type	Interaxis 45mm	Interaxis 48mm
	<p>Ø 35 45 9.5</p>	<p>Ø 35 48 6</p>
Item number		

Cranking
9mm

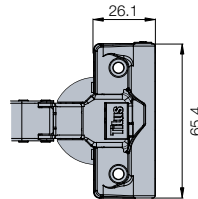
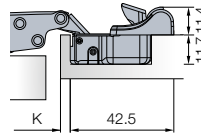
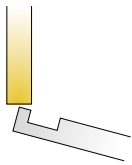

	701-0D64-650	701-0D66-650
	701-0D70-650	701-0D72-650
	701-0D76-650	701-0D78-650

Drilling patterns for hinge cups → see page 2.17

100 Pcs

Cup made of steel, arm made of zinc

Mounting plates



Cam adjustable cruciform mounting plate
→ see page 2.81



Cruciform mounting plate
→ see page 2.83



Cam adjustable linear mounting plate
→ see page 2.81



Face frame adapter plate
→ see page 2.83

Hinge cup screws

If not pre-mounted

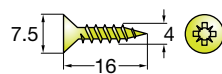

820-6328-050

10000 Pcs

Accessories



Cover caps for hinge arm
→ see page 2.177



Hinge angle restrictor
→ see page 2.175

Legend of hinge cup symbols

Screw-on ready
← screws

Machine insertion ready

EasyFix system

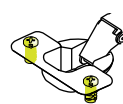
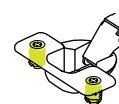
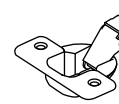

Damping adjustment

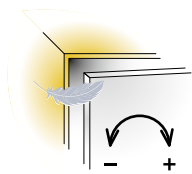

Door adjustment

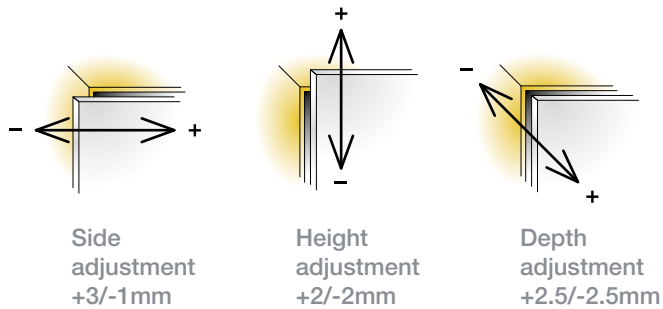

For further explanation → see page 2.25

For further explanation → see pages 2.22-2.24

Mounting details

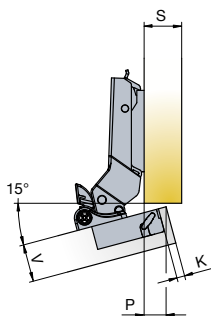
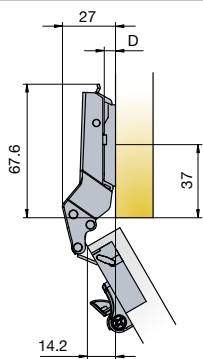

Mounting plate drilling distance

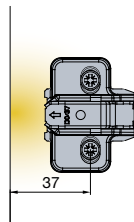

Mounting plate thickness table

For further explanation → see page 2.13

P	11	12	13	14	15	16	17	18
3	4	3	2	1	0			
4		4	3	2	1	0		
5			4	3	2	1	0	
6				4	3	2	1	0

Drawings show application on D=0mm mounting plate

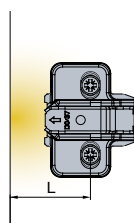
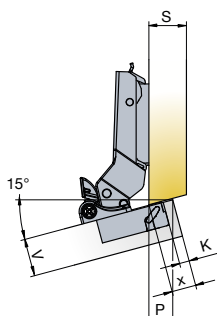
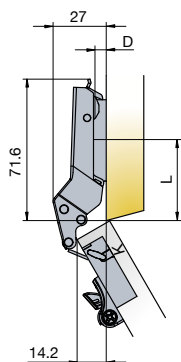

P	6	7	8	9	10	11	12	13
3	4	3	2	1	0			
4		4	3	2	1	0		
5			4	3	2	1	0	
6				4	3	2	1	0

Drawings show application on D=0mm mounting plate

L=45 for thickness D=0
 L=44 for thickness D=1
 L=43 for thickness D=2
 L=42 for thickness D=3
 L=41 for thickness D=4

Touch opening



PushOpen Solutions
 → see pages 2.199-2.204

Door clearance at R=1mm

For further explanation → see page 2.14

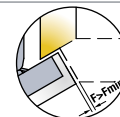

V	16	17	18	19	20	21	22	23	24	25	26
3	0.5	0.7	0.8	1	1.2	1.5	1.7	2.1	2.8	4.1	5.5
4	0.4	0.7	0.8	1	1.2	1.5	1.7	2.1	2.3	3.1	4.5
5	0.4	0.6	0.7	0.9	1.1	1.4	1.6	2	2.2	2.6	3.5
6	0.4	0.6	0.7	0.9	1.1	1.4	1.6	2	2.2	2.6	2.9

Gap Z_{MIN}=0

T-type-i 110/30°

30° angled application for wood doors

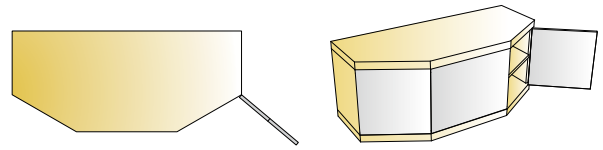
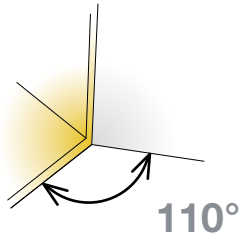

- Opening angle 110°
- Drilling diameter for hinge cup 35mm
- Drilling depth 12mm
- Hinge on plate mounting system 3Way snap-on



Technical details

Cup type	Interaxis 45mm	Interaxis 48mm
Item number	Item number	Item number
	701-0E52-650	701-0E54-650
	701-0E58-650	701-0E60-650
	701-0E64-650	701-0E66-650

Cranking
9mm

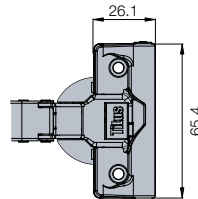
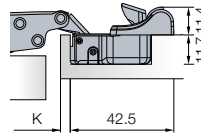
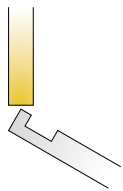

Drilling patterns for hinge cups → see page 2.17

100 Pcs

Cup made of steel, arm made of zinc

Mounting plates

- Cam adjustable cruciform mounting plate → see page 2.81
- Cruciform mounting plate → see page 2.83
- Cam adjustable linear mounting plate → see page 2.81
- Face frame adapter plate → see page 2.83

Hinge cup screws

If not pre-mounted

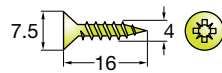

820-6328-050

10000 Pcs

Accessories

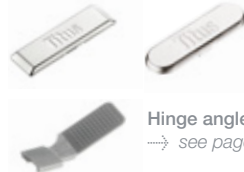

Cover caps for hinge arm → see page 2.177

Hinge angle restrictor → see page 2.175

Legend of hinge cup symbols

Screw-on ready
← screws

Machine insertion ready

EasyFix system

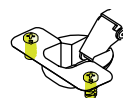
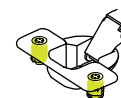

Damping adjustment

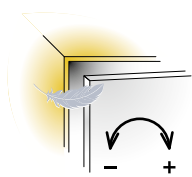

Door adjustment

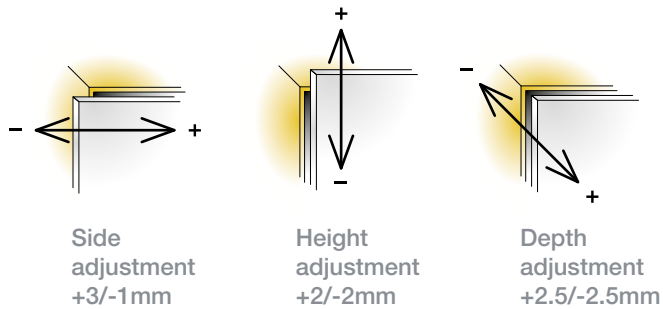

For further explanation → see page 2.25

For further explanation → see pages 2.22-2.24

Mounting details

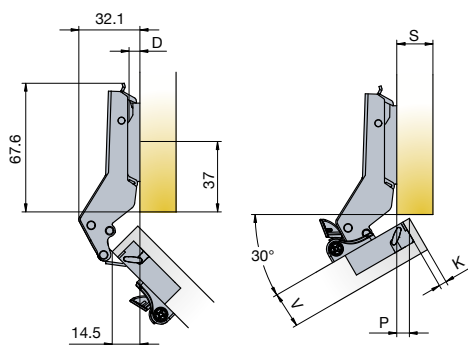

Mounting plate drilling distance

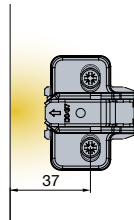

Mounting plate thickness table

For further explanation → see page 2.13

P	1.5	2.5	3.5	4.5	5.5	6.5	7.5	8.5
3	4	3	2	1	0			
4		4	3	2	1	0		
5			4	3	2	1	0	
6				4	3	2	1	0

Drawings show application on D=0mm mounting plate

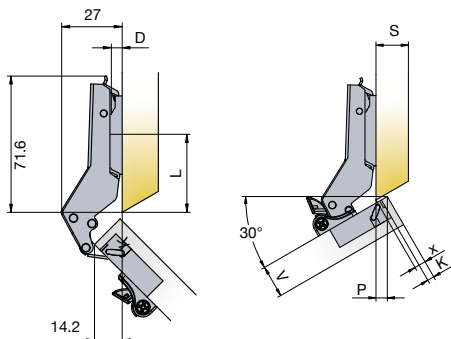

X	2	3	4	5	6	7	8	9
3	4	3	2	1	0			
4		4	3	2	1	0		
5			4	3	2	1	0	
6				4	3	2	1	0

Drawings show application on D=0mm mounting plate

L=41 for thickness D=0
 L=41 for thickness D=1
 L=40 for thickness D=2
 L=40 for thickness D=3
 L=39 for thickness D=4

Touch opening



PushOpen Solutions
 → see pages 2.199-2.204

Door clearance at R=1mm

For further explanation → see page 2.14

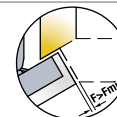

V	16	17	18	19	20	21	22	23	24	25	26
3	0.5	0.7	0.8	1	1.2	1.5	1.7	2.1	2.8	4.1	5.5
4	0.4	0.7	0.8	1	1.2	1.5	1.7	2.1	2.3	3.1	4.5
5	0.4	0.6	0.7	0.9	1.1	1.4	1.6	2	2.2	2.6	3.5
6	0.4	0.6	0.7	0.9	1.1	1.4	1.6	2	2.2	2.6	2.9

Gap Z_{MIN}=0

T-type-i 110/45°

45° angled application for wood doors

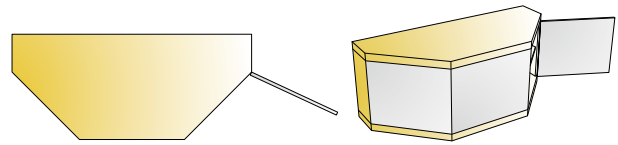
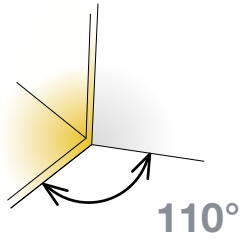

- Opening angle 110°
- Drilling diameter for hinge cup 35mm
- Drilling depth 12mm
- Hinge on plate mounting system 3Way snap-on



Technical details

Cup type	Interaxis 45mm	Interaxis 48mm
Item number	Item number	Item number
	701-0D82-650	701-0D84-650
	701-0D88-650	701-0D90-650
	701-0D98-650	701-0E32-650

Cranking
9mm

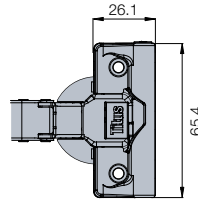
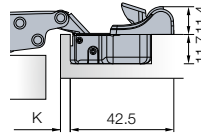
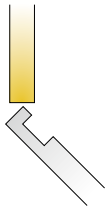

Drilling patterns for hinge cups → see page 2.17

100 Pcs

Cup made of steel, arm made of zinc

Mounting plates



Cam adjustable cruciform mounting plate
→ see page 2.81



Cruciform mounting plate
→ see page 2.83



Cam adjustable linear mounting plate
→ see page 2.81



Face frame adapter plate
→ see page 2.83

Hinge cup screws If not pre-mounted

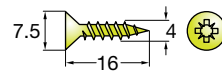

820-6328-050

10000 Pcs

Accessories



Cover caps for hinge arm
→ see page 2.177



Hinge angle restrictor
→ see page 2.175

Legend of hinge cup symbols

Screw-on ready
← screws

Machine insertion ready

EasyFix system

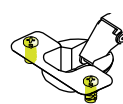
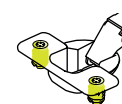
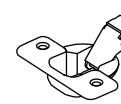

Damping adjustment

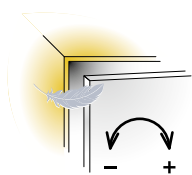

Door adjustment

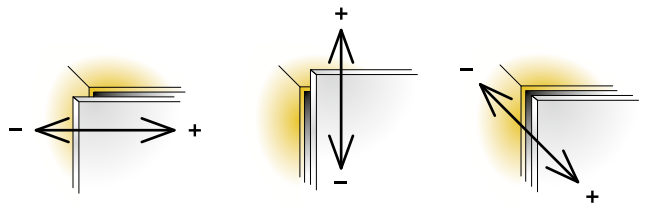

Side adjustment
+3/-1mm

Height adjustment
+2/-2mm

Depth adjustment
+2.5/-2.5mm

For further explanation → see page 2.25

For further explanation → see pages 2.22-2.24

Mounting details

Mounting plate drilling distance

Mounting plate thickness table

For further explanation → see page 2.13

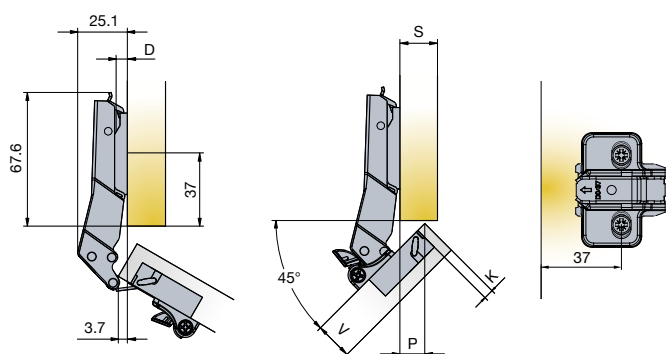

P	7	7.5	8	8.5	9	9.5	10	10.5	11	11.5	12	12.5	13	13.5
3	4		3		2		1		0					
4			4		3		2		1		0			
5				4	3		2		1		0			
6						4	3		2		1		0	

Drawings show application on D=0mm mounting plate

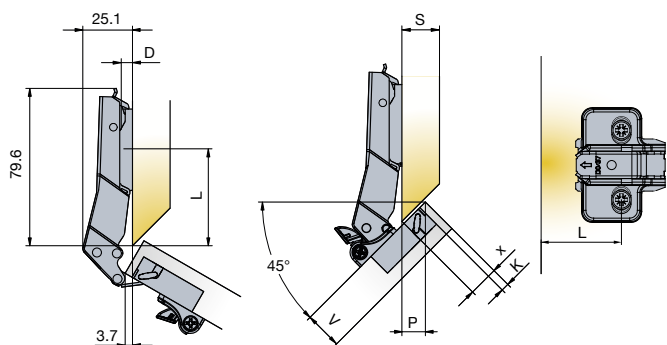

X	10	11	12	13	14	15	16	17	
3	4	3	2	1	0				
4		4	3	2	1	0			
5			4	3	2	1	0		
6				4	3	2	1	0	D

Drawings show application on D=0mm mounting plate

L=49 for thickness D=0
L=48 for thickness D=1
L=47 for thickness D=2
L=46 for thickness D=3
L=45 for thickness D=4

Touch opening



PushOpen Solutions
→ see pages 2.199-2.204

Door clearance at R=1mm

For further explanation → see page 2.14

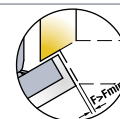

V	16	17	18	19	20	21	22	23	24	25	26
3	0.5	0.7	0.8	1	1.2	1.5	1.7	2.1	2.8	4.1	5.5
4	0.4	0.7	0.8	1	1.2	1.5	1.7	2.1	2.3	3.1	4.5
5	0.4	0.6	0.7	0.9	1.1	1.4	1.6	2	2.2	2.6	3.5
6	0.4	0.6	0.7	0.9	1.1	1.4	1.6	2	2.2	2.6	2.9 F _{MIN}

Gap Z_{MIN}=0

T-type-i 110/45°

45° angled application for wood doors

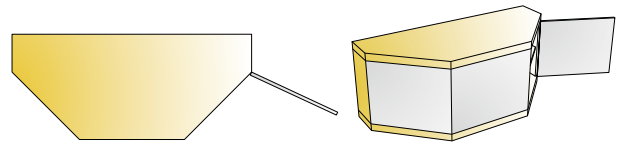
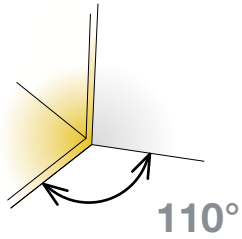

- Opening angle 110°
- Drilling diameter for hinge cup 35mm
- Drilling depth 12mm
- Hinge on plate mounting system 3Way snap-on



Technical details

Cup type	Interaxis 45mm	Interaxis 48mm
	<p>Ø 35</p>	<p>Ø 35</p>
Item number		

Cranking
17mm

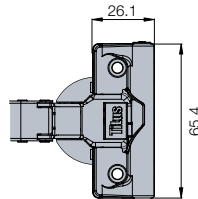
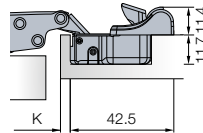
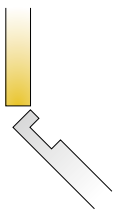

	701-0B08-650	701-0B10-650
	701-0C78-650	701-0C80-650
	701-0C54-650	701-0C56-650

Drilling patterns for hinge cups → see page 2.17

100 Pcs

Cup made of steel, arm made of zinc

Mounting plates



Cam adjustable cruciform mounting plate
→ see page 2.81



Cruciform mounting plate
→ see page 2.83



Cam adjustable linear mounting plate
→ see page 2.81



Face frame adapter plate
→ see page 2.83

Hinge cup screws

If not pre-mounted

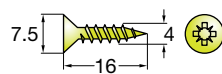

820-6328-050

10000 Pcs

Accessories



Cover caps for hinge arm
→ see page 2.177



Hinge angle restrictor
→ see page 2.175

Legend of hinge cup symbols

Screw-on ready
← screws

Machine insertion ready

EasyFix system

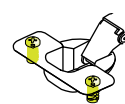
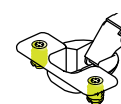
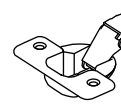

Damping adjustment

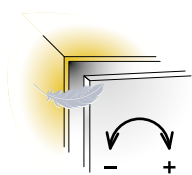

Door adjustment

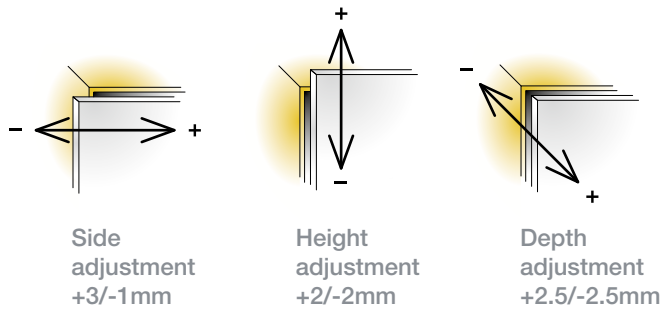

For further explanation → see page 2.25

For further explanation → see pages 2.22-2.24

Mounting details

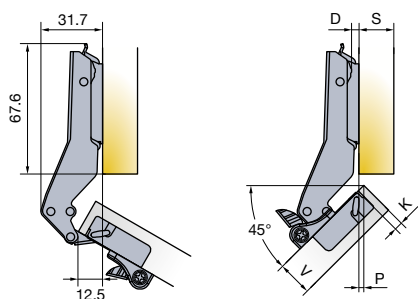

Mounting plate drilling distance

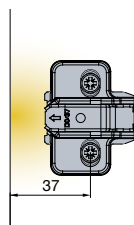

Mounting plate thickness table

For further explanation → see page 2.13

P	0	0.5	1	1.5	2	2.5	3	3.5	4
3		2		1		0			
4	3		2		1		0		
5		3		2		1		0	
6	4		3		2		1		0

Drawings show application on D=0mm mounting plate

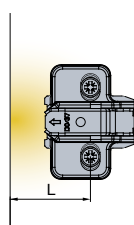
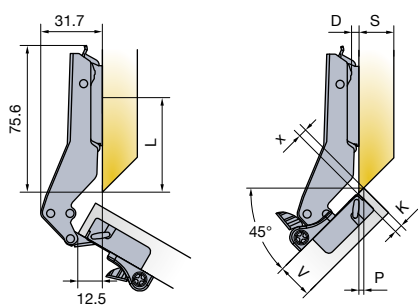

X	0	0.5	1	1.5	2	2.5	3	3.5	4	4.5	5	6
3	2			1			0					
4			2			1			0			
5		3			2			1			0	
6	4			3			2			1		0

Drawings show application on D=0mm mounting plate

L=45 for thickness D=0
 L=44 for thickness D=1
 L=43 for thickness D=2
 L=42 for thickness D=3
 L=41 for thickness D=4

Touch opening



PushOpen Solutions
 → see pages 2.199-2.204

Door clearance at R=1mm

For further explanation → see page 2.14

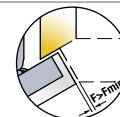

V	16	17	18	19	20	21	22	23	24	25	26
3	0.5	0.7	0.8	1	1.2	1.5	1.7	2.1	2.8	4.1	5.5
4	0.4	0.7	0.8	1	1.2	1.5	1.7	2.1	2.3	3.1	4.5
5	0.4	0.6	0.7	0.9	1.1	1.4	1.6	2	2.2	2.6	3.5
6	0.4	0.6	0.7	0.9	1.1	1.4	1.6	2	2.2	2.6	2.9

Gap Z_{MIN}=0

T-type-i 110/45°

45° angled application for wood doors

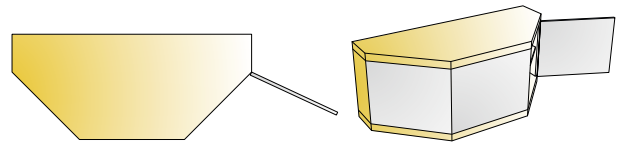
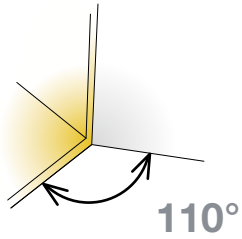

- Opening angle 110°
- Drilling diameter for hinge cup 35mm
- Drilling depth 12mm
- Hinge on plate mounting system 3Way snap-on



Technical details

Cup type	Interaxis 45mm	Interaxis 48mm
	<p>45 9.5 Ø 35</p>	<p>48 6 Ø 35</p>
Item number	701-0W59-650	701-0W60-650
Item number	701-0W62-650	701-0W63-650
EasyFix	701-0W65-650	701-0W66-650

Cranking
23mm

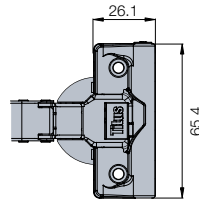
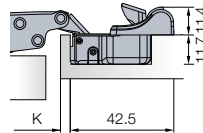
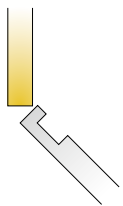

Drilling patterns for hinge cups → see page 2.17

100 Pcs

Cup made of steel, arm made of zinc

Mounting plates

Cam adjustable cruciform mounting plate
→ see page 2.81

Cruciform mounting plate
→ see page 2.83

Cam adjustable linear mounting plate
→ see page 2.81

Face frame adapter plate
→ see page 2.83

Hinge cup screws

If not pre-mounted

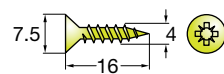

820-6328-050

10000 Pcs

Accessories



Cover caps for hinge arm
→ see page 2.177



Hinge angle restrictor
→ see page 2.175

Legend of hinge cup symbols

Screw-on ready
← screws

Machine insertion ready

EasyFix system

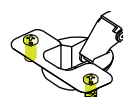
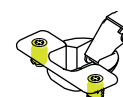

Damping adjustment

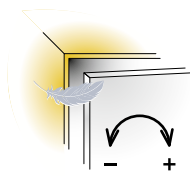

Door adjustment

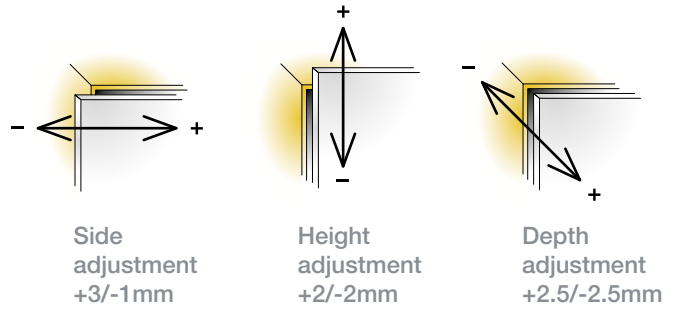

For further explanation → see page 2.25

For further explanation → see pages 2.22-2.24

Mounting details

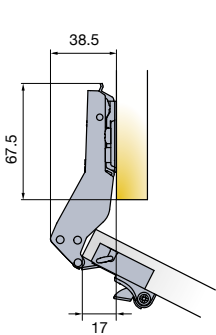

Mounting plate drilling distance

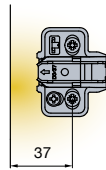
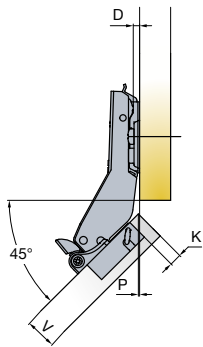

Mounting plate thickness table

For further explanation → see page 2.13

P	7.5	7	6.5	6	5.5	5	4.5	4	3.5	3	2.5	2	1.5
3	4		3		2		1		0				
4		4		3		2		1		0			
5				4		3		2		1		0	
6					4		3		2		1		0

Touch opening



PushOpen Solutions
→ see pages 2.199-2.204

Door clearance at R=1mm

For further explanation → see page 2.14

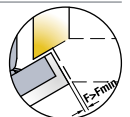

V	16	17	18	19	20	21	22	23	24	25	26
3	0.5	0.7	0.8	1	1.2	1.5	1.7	2.1	2.8	4.1	5.5
4	0.4	0.7	0.8	1	1.2	1.5	1.7	2.1	2.3	3.1	4.5
5	0.4	0.6	0.7	0.9	1.1	1.4	1.6	2	2.2	2.6	3.5
6	0.4	0.6	0.7	0.9	1.1	1.4	1.6	2	2.2	2.6	2.9 F _{MIN}

Gap Z_{MIN}=0

T-type-i 110/90°

For wood door cabinets with blind panels

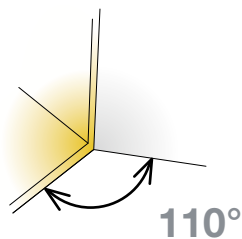
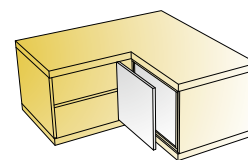

- Opening angle 110°
- Drilling diameter for hinge cup 35mm
- Drilling depth 12mm
- Hinge on plate mounting system 3Way snap-on



Technical details

Cup type	Interaxis 45mm	Interaxis 48mm
Item number	Item number	Item number
	701-0A96-650	701-0A98-650
	701-0D36-650	701-0D38-650
	701-0D30-650	701-0D32-650

Cranking
17mm

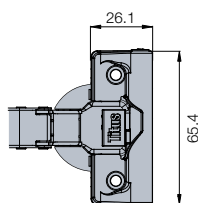
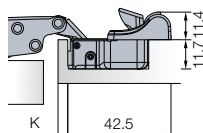
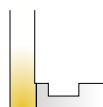

Drilling patterns for hinge cups → see page 2.17

100 Pcs

Cup made of steel, arm made of zinc

Mounting plates

Cam adjustable cruciform mounting plate
→ see page 2.81

Cruciform mounting plate
→ see page 2.83

Cam adjustable linear mounting plate
→ see page 2.81

Face frame adapter plate
→ see page 2.83

Hinge cup screws
If not pre-mounted
 7.5
16

820-6328-050
10000 Pcs

Accessories

Cover caps for hinge arm
→ see page 2.177

Hinge angle restrictor
→ see page 2.175

Legend of hinge cup symbols

Screw-on ready
← screws

Machine insertion ready

EasyFix system

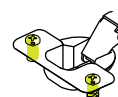
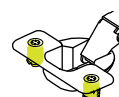

Damping adjustment

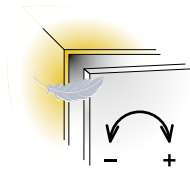

Door adjustment

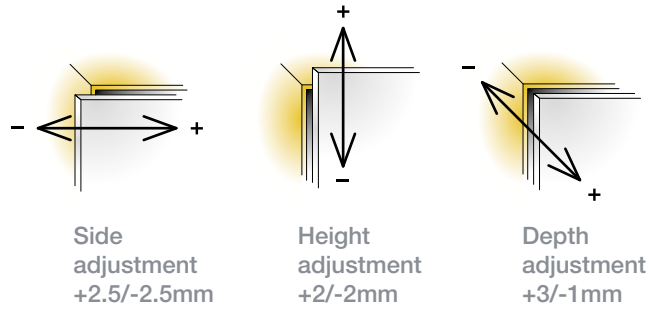

For further explanation → see page 2.25

For further explanation → see pages 2.22-2.24

Mounting details

Mounting plate drilling distance

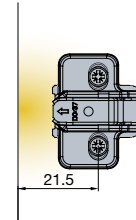
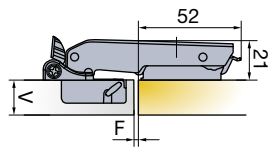
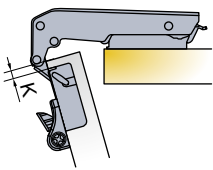

Drawing shows application on D=2mm mounting plate

Drawing shows application on D=2mm mounting plate

Touch opening



PushOpen Solutions
→ see pages 2.199-2.204

Door clearance at R=1mm

For further explanation → see page 2.14

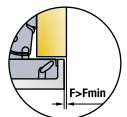

V	16	17	18	19	20	21	22	23	24	25	26
3	0.5	0.7	0.8	1	1.2	1.5	1.7	2.1	2.8	4.1	5.5
4	0.4	0.7	0.8	1	1.2	1.5	1.7	2.1	2.3	3.1	4.5
K											
5	0.4	0.6	0.7	0.9	1.1	1.4	1.6	2	2.2	2.6	3.5
6	0.4	0.6	0.7	0.9	1.1	1.4	1.6	2	2.2	2.6	2.9 F _{MIN}

Gap Z_{MIN}=0

T-type-i 120

For wood doors

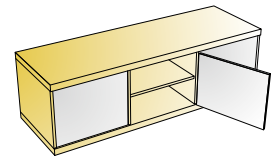
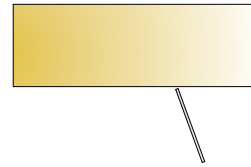
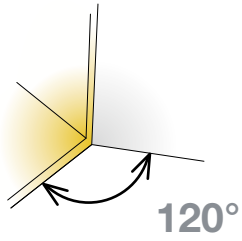

- Opening angle
- Drilling diameter for hinge cup
- Drilling depth
- Hinge on plate mounting system

120°
35mm
12mm
3Way snap-on



Technical details

Cup type	Interaxis 45mm	Interaxis 48mm
Item number	701-OUT0-054	701-0US0-054
Item number	701-OUT1-054	701-0US1-054
EasyFix 	701-OUT4-054	701-0US4-054

Drilling patterns for hinge cups → see page 2.17

Cranking
0mm

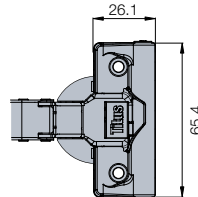
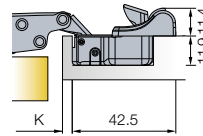
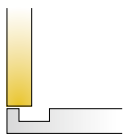

150 Pcs

Made of steel

Mounting plates



Cam adjustable cruciform mounting plate
→ see page 2.81



Cruciform mounting plate
→ see page 2.83



Cam adjustable linear mounting plate
→ see page 2.81



Face frame adapter plate
→ see page 2.83

Hinge cup screws If not pre-mounted

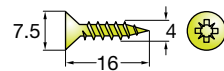

820-6328-050

10000 Pcs

Accessories



Cover caps for hinge arm
→ see page 2.177

Legend of hinge cup symbols

Screw-on ready
← screws

Machine insertion ready

EasyFix system

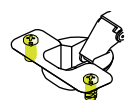
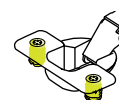

Damping adjustment

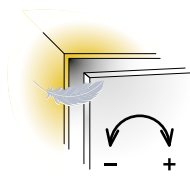

For further explanation → see page 2.25

Door adjustment

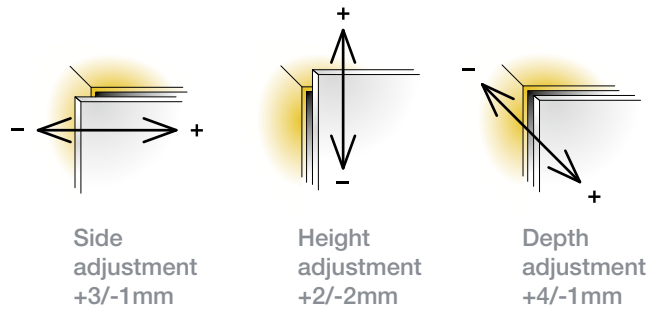

Side adjustment
+3/-1mm

Height adjustment
+2/-2mm

Depth adjustment
+4/-1mm

For further explanation → see pages 2.22-2.24

Mounting details

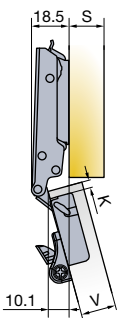

Drawings show application on D=0mm mounting plate

Mounting plate drilling distance

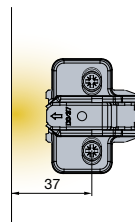
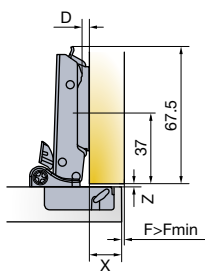

Mounting plate thickness table

For further explanation → see page 2.13

X	13	14	15	16	17	18	19
3	3	2	1	0			
4	4	3	2	1	0		
K							
5		4	3	2	1	0	
6			4	3	2	1	0

$D=13+K-X$

Touch opening



PushOpen Solutions
→ see pages 2.199-2.204

Door clearance at R=1mm

For further explanation → see page 2.14

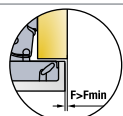

V	16	17	18	19
3	1.1	0.4	0	0
K				
4	2	1.4	0.7	0.1
5	3	2.3	1.6	1

Gap Z_{MIN} =2

T-type-i 95 Thick Door Hinge

For wood doors

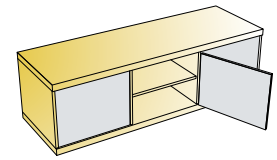
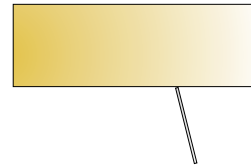
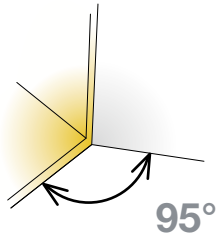

- Opening angle
- Drilling diameter for hinge cup
- Drilling depth
- Hinge on plate mounting system

95°
35mm
12mm
3Way snap-on



Technical details

Cup type	Interaxis 45mm	Interaxis 48mm
Item number		

Cranking
0mm

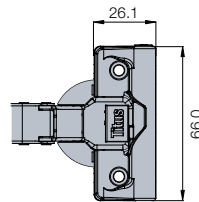
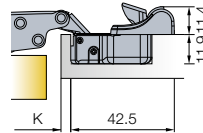
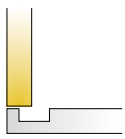

	708-0XT0-054	708-0XS0-054
	708-0XT1-054	708-0XS1-054
	708-0XT4-054	708-0XS4-054

Drilling patterns for hinge cups → see page 2.17

150 Pcs Made of steel

Cranking
5mm

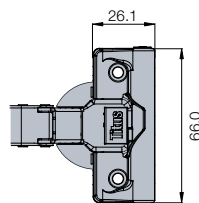
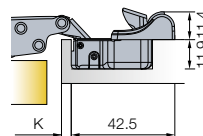
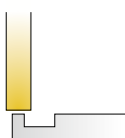

	708-0YT0-054	708-0YS0-054
	708-0YT1-054	708-0YS1-054
	708-0YT4-054	708-0YS4-054

Drilling patterns for hinge cups → see page 2.17

150 Pcs Made of steel

Mounting plates



Cam adjustable cruciform mounting plate
→ see page 2.81



Cruciform mounting plate
→ see page 2.83



Cam adjustable linear mounting plate
→ see page 2.81



Face frame adapter plate
→ see page 2.83

Hinge cup screws If not pre-mounted

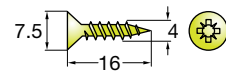

820-6328-050
 10000 Pcs

Accessories



Cover caps for hinge arm
→ see page 2.177

Legend of hinge cup symbols

Screw-on ready
← screws

Machine insertion ready

EasyFix system



Touch opening

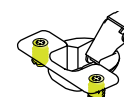

PushOpen Solutions
→ see pages 2.199-2.204

Damping adjustment

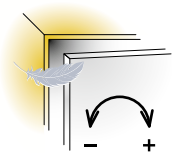

Door adjustment

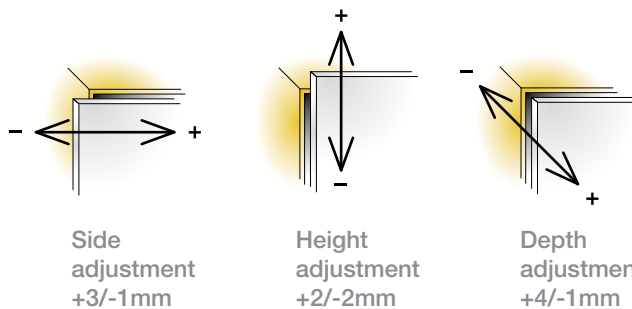

Side adjustment
+3/-1mm

Height adjustment
+2/-2mm

Depth adjustment
+4/-1mm

For further explanation → see page 2.25

For further explanation → see pages 2.22-2.24

Mounting details

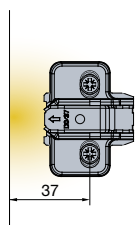
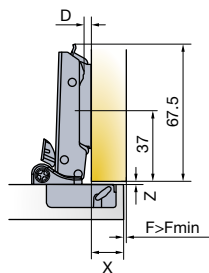
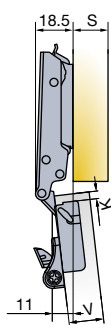

Drawings show application on D=0mm mounting plate

Mounting plate drilling distance

Mounting plate thickness table

For further explanation → see page 2.13

X	13	14	15	16	17	18	19	20	21	22
3	3	2	1	0						
4	4	3	2	1	0					
5		4	3	2	1	0				
K 6			4	3	2	1	0			
7				4	3	2	1	0		
8					4	3	2	1	0	
9						4	3	2	1	0

$D=13+K-X$

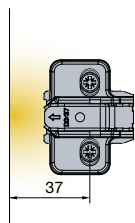
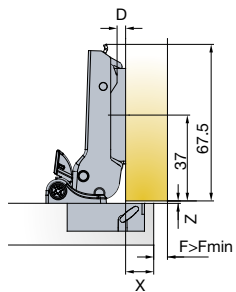
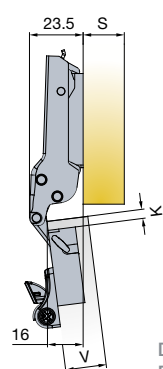

Drawings show application on D=0mm mounting plate

X	8	9	10	11	12	13	14	15	16	17
3	3	2	1	0						
4	4	3	2	1	0					
5		4	3	2	1	0				
K 6			4	3	2	1	0			
7				4	3	2	1	0		
8					4	3	2	1	0	
9						4	3	2	1	0

$D=8+K-X$

Gap Z

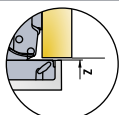

V	20	22	24	26	28	30	32	34	
3	0	0	0	0	0	0	0	0	
4	0	0	0	0	0	0	0	0	
5	0	0	0	0	0	0	0	0	
K 6	0	0	0	0	0	0	0	0	
7	0	0	0	0	0	0	0	0	
8	0	0	0	0	0	0	0	0	
9	0	0	1.6	1.7	1.8	2.0	2.1	2.3	Z _{MIN}

Door clearance at R=1mm

For further explanation → see page 2.14



V	20	22	24	26	28	30	32	34	
3	0.6	0.9	1.3	1.7	2.2	4.0	5.9	7.8	
4	0.6	0.9	1.2	1.7	2.2	3.4	5.2	7.1	
5	0.6	0.9	1.2	1.6	2.1	2.9	4.6	6.5	
K 6	0.6	0.9	1.2	1.5	2.1	2.6	4.1	5.9	
7	0.6	0.9	1.2	1.5	2.1	2.6	3.6	5.3	
8	0.6	0.8	1.2	1.5	2.0	2.5	3.2	4.8	
9	0.6	0.8	1.2	1.5	2.0	2.5	3.1	4.4	F _{MIN}

T-type-i 95 Thick Door Hinge

For wood doors

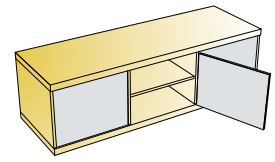
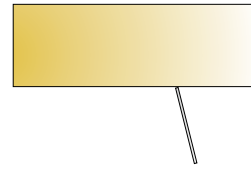
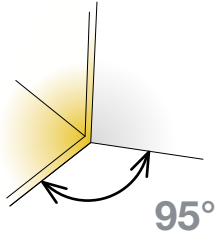

- Opening angle
- Drilling diameter for hinge cup
- Drilling depth
- Hinge on plate mounting system

95°
35mm
12mm
3Way snap-on



Technical details

	Interaxis 45mm	Interaxis 48mm
Cup type	Item number	Item number
	708-0ZT0-054	708-0ZS0-054
	708-0ZT1-054	708-0ZS1-054
	708-0ZT4-054	708-0ZS4-054
Drilling patterns for hinge cups → see page 2.17		

Cranking
9mm

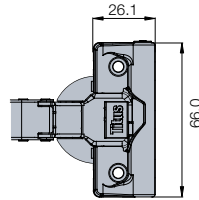
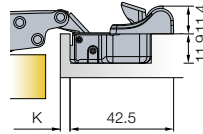
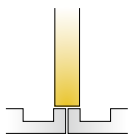

150 Pcs

Made of steel

Cranking
17mm

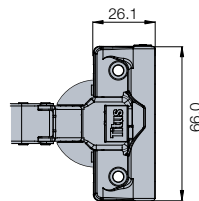
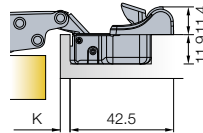
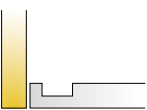

150 Pcs

Made of steel

	708-0WT0-054	708-0WS0-054
	708-0WT1-054	708-0WS1-054
	708-0WT4-054	708-0WS4-054
Drilling patterns for hinge cups → see page 2.17		

Mounting plates



Cam adjustable cruciform mounting plate
→ see page 2.81



Cruciform mounting plate
→ see page 2.83



Cam adjustable linear mounting plate
→ see page 2.81



Face frame adapter plate
→ see page 2.83

Hinge cup screws If not pre-mounted

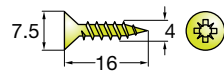

820-6328-050
 10000 Pcs

Accessories



Cover caps for hinge arm
→ see page 2.177

Legend of hinge cup symbols

Screw-on ready
← screws

Machine insertion ready

EasyFix system

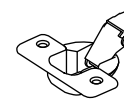

Touch opening

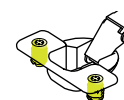

PushOpen Solutions
→ see pages 2.199-2.204

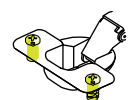

Damping adjustment

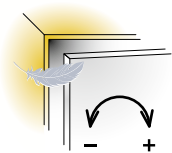

Door adjustment

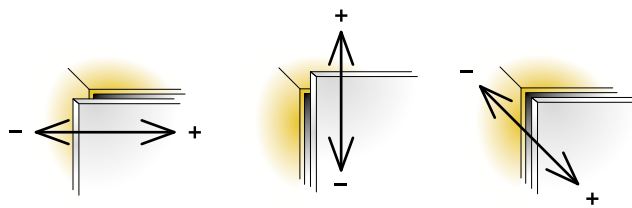

Side adjustment
+3/-1mm

Height adjustment
+2/-2mm

Depth adjustment
+4/-1mm

For further explanation → see page 2.25

For further explanation → see pages 2.22-2.24

Mounting details

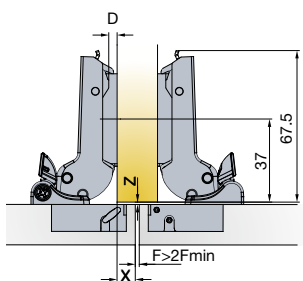
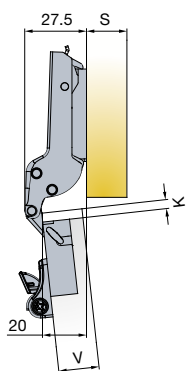

Mounting plate drilling distance

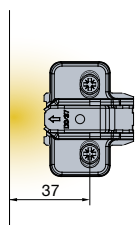

Mounting plate thickness table

For further explanation → see page 2.13

X	4	5	6	7	8	9	10	11	12	13
3	3	2	1	0						
4	4	3	2	1	0					
5		4	3	2	1	0				
K 6			4	3	2	1	0			
7				4	3	2	1	0		
8					4	3	2	1	0	
9						4	3	2	1	0

$D=4+K-X$

Drawings show application on D=0mm mounting plate

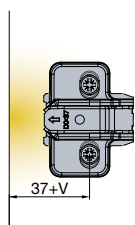
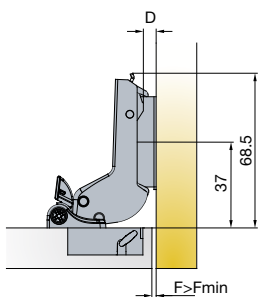
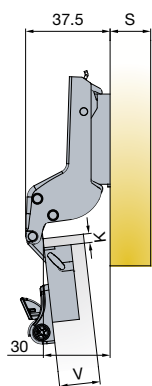

V	20	22	24	26	28	30	32
3	0	0	1	1	2	3	4*
4	1	1	2	2	3	4	4*
K 5	2	2	3	3	4	4	4*
6	3	3	4	4	4*	4*	
7	4	4	4*	4*	4*	4*	D

$D=-4+K+F$

*Hinge adjustment needed

Drawings show application on D=2mm mounting plate

Gap Z

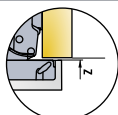

V	20	22	24	26	28	30	32	34
3	0	0	0	0	0	0	0	0
4	0	0	0	0	0	0	0	0
5	0	0	0	0	0	0	0	0
K 6	0	0	0	0	0	0	0	0
7	0	0	0	0	0	0	0	0
8	0	0	0	0	0	0	0	0
9	0	0	1.6	1.7	1.8	2.0	2.1	2.3

Z_{MIN}

Door clearance at R=1mm

For further explanation → see page 2.14

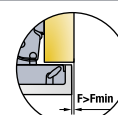

V	20	22	24	26	28	30	32	34
3	0.6	0.9	1.3	1.7	2.2	4.0	5.9	7.8
4	0.6	0.9	1.2	1.7	2.2	3.4	5.2	7.1
5	0.6	0.9	1.2	1.6	2.1	2.9	4.6	6.5
K 6	0.6	0.9	1.2	1.5	2.1	2.6	4.1	5.9
7	0.6	0.9	1.2	1.5	2.1	2.6	3.6	5.3
8	0.6	0.8	1.2	1.5	2.0	2.5	3.2	4.8
9	0.6	0.8	1.2	1.5	2.0	2.5	3.1	4.4

F_{MIN}

T-type 110

For wood doors

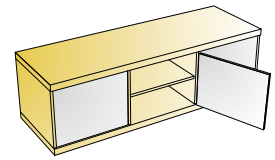
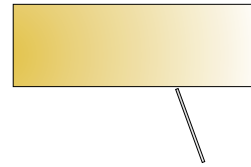
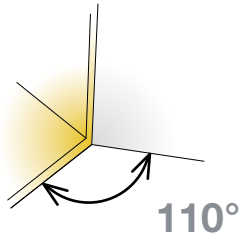

- Opening angle
- Drilling diameter for hinge cup
- Drilling depth
- Hinge on plate mounting system

110°
35mm
12mm
3Way snap-on



Technical details

Cup type	Interaxis 45mm	Interaxis 48mm
	Item number	Item number

Cranking
0mm

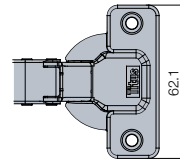
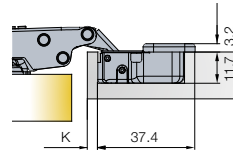
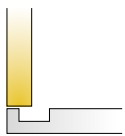

	702-0AK0-054	702-0AL0-054
	702-0AK1-054	702-0AL1-054
	702-0AK4-054	702-0AL4-054

Drilling patterns for hinge cups → see page 2.17

150 Pcs

Made of steel

Cranking
5mm

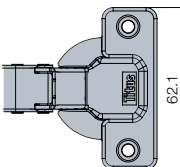
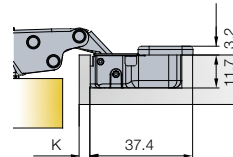
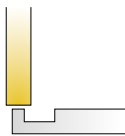

	702-0BK0-054	702-0BL0-054
	702-0BK1-054	702-0BL1-054
	702-0BK4-054	702-0BL4-054

Drilling patterns for hinge cups → see page 2.17

150 Pcs

Made of steel

Mounting plates



Cam adjustable cruciform mounting plate
→ see page 2.81



Cruciform mounting plate
→ see page 2.83



Cam adjustable linear mounting plate
→ see page 2.81



Face frame adapter plate
→ see page 2.83

Hinge cup screws

If not pre-mounted

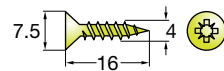

820-6328-050

10000 Pcs

Accessories



Cover caps for hinge arm
→ see page 2.177



Hinge angle restrictor
→ see page 2.175

Legend of hinge cup symbols

Screw-on ready
← screws

Machine insertion ready

EasyFix system

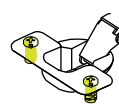
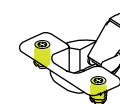
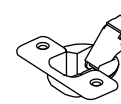

Door adjustment

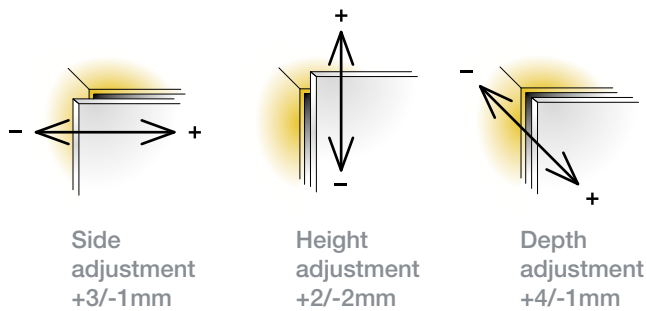

For further explanation → see pages 2.22-2.24

Mounting details

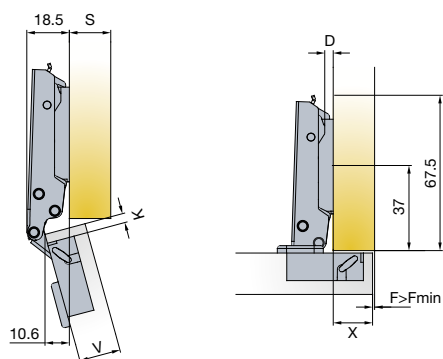

Drawings show application on D=0mm mounting plate

Mounting plate drilling distance

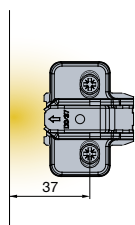

Mounting plate thickness table

For further explanation → see page 2.13

X	13	14	15	16	17	18	19
3	3	2	1	0			
4	4	3	2	1	0		
K							
5		4	3	2	1	0	
6			4	3	2	1	0
							D

$D=13+K-X$

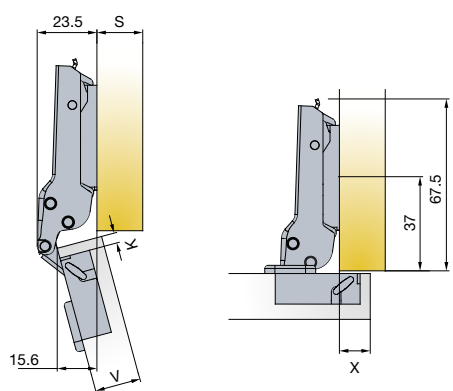

Drawings show application on D=0mm mounting plate

x	8	9	10	11	12	13	14
3	3	2	1	0			
4	4	3	2	1	0		
K							
5		4	3	2	1	0	
6			4	3	2	1	0
							D

$D=8+K-X$

Soft closing systems



Glissando TT
→ see page 2.189



Glissando CR
→ see page 2.195

Touch opening



PushOpen Solutions
→ see pages 2.199-2.204

Door clearance at R=1mm

For further explanation → see page 2.14

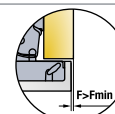

V	16	17	18	19	20	21	22	23	24	25	26
3	0.5	0.7	0.8	1	1.2	1.5	1.7	2.1	2.8	4.1	5.5
4	0.4	0.7	0.8	1	1.2	1.5	1.7	2.1	2.3	3.1	4.5
K											
5	0.4	0.6	0.7	0.9	1.1	1.4	1.6	2	2.2	2.6	3.5
6	0.4	0.6	0.7	0.9	1.1	1.4	1.6	2	2.2	2.6	2.9
											F _{MIN}

Gap Z_{MIN}=0

T-type 110

For wood doors

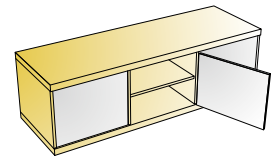
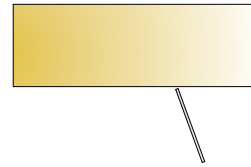
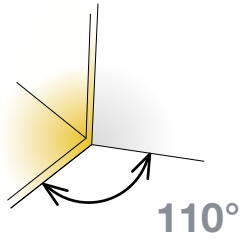

- Opening angle
- Drilling diameter for hinge cup
- Drilling depth
- Hinge on plate mounting system

110°
35mm
12mm
3Way snap-on



Technical details

Cup type	Interaxis 45mm	Interaxis 48mm
Item number		

Cranking

9mm

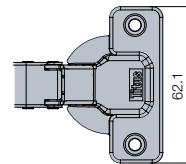
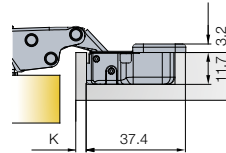
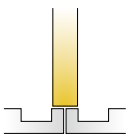

	702-0CK0-054	702-0CL0-054
	702-0CK1-054	702-0CL1-054
	702-0CK4-054	702-0CL4-054

Drilling patterns for hinge cups → see page 2.17

150 Pcs

Made of steel

Cranking

17mm

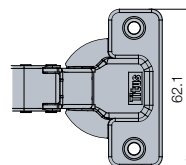
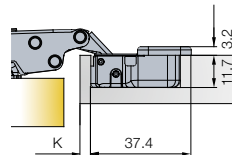
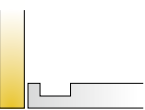

	702-0DK0-054	702-0DL0-054
	702-0DK1-054	702-0DL1-054
	702-0DK4-054	702-0DL4-054

Drilling patterns for hinge cups → see page 2.17

150 Pcs

Made of steel

Mounting plates

Cam adjustable cruciform mounting plate
→ see page 2.81

Cruciform mounting plate
→ see page 2.83

Cam adjustable linear mounting plate
→ see page 2.81

Face frame adapter plate
→ see page 2.83

Hinge cup screws

If not pre-mounted

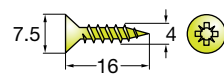

820-6328-050

10000 Pcs

Accessories

Cover caps for hinge arm
→ see page 2.177

Hinge angle restrictor
→ see page 2.175

Legend of hinge cup symbols

Screw-on ready
← screws

Machine insertion ready

EasyFix system

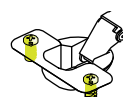
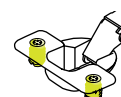
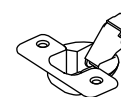

Door adjustment

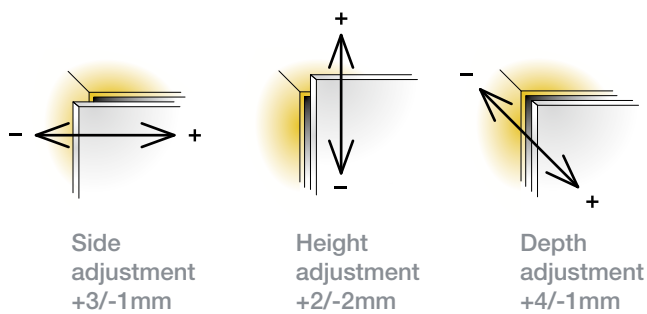

For further explanation → see pages 2.22-2.24

Mounting details

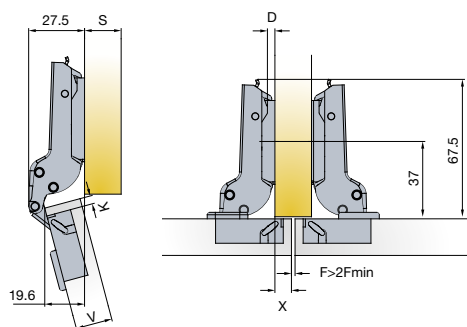

Drawings show application on D=0mm mounting plate

Mounting plate drilling distance

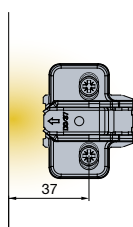

Mounting plate thickness table

For further explanation → see page 2.13

X	4	5	6	7	8	9	10
3	3	2	1	0			
4	4	3	2	1	0		
K							
5		4	3	2	1	0	
6			4	3	2	1	0
							D

$D=4+K-X$

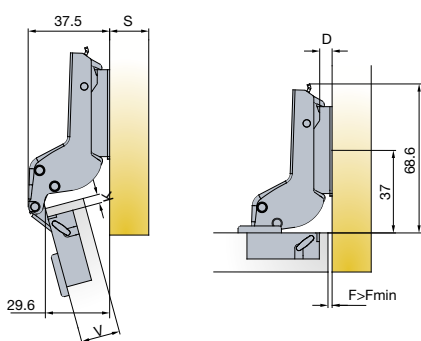

Drawings show application on D=2mm mounting plate

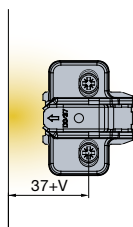

V	16	17	18	19	20	21	22	23	24
3	0	0	0	0	1	1	1	1	2
4	1	1	1	1	2	2	2	2	3
K									
5	2	2	2	2	3	3	3	3	4
6	3	3	3	3	4	4	4	4	
									D

$D=-4+K+F$

Soft closing systems



Glissando TT
→ see page 2.189



Glissando CR
→ see page 2.195

Touch opening



PushOpen Solutions
→ see pages 2.199-2.204

Door clearance at R=1mm

For further explanation → see page 2.14

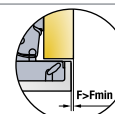

V	16	17	18	19	20	21	22	23	24	25	26
3	0.5	0.7	0.8	1	1.2	1.5	1.7	2.1	2.8	4.1	5.5
4	0.4	0.7	0.8	1	1.2	1.5	1.7	2.1	2.3	3.1	4.5
K											
5	0.4	0.6	0.7	0.9	1.1	1.4	1.6	2	2.2	2.6	3.5
6	0.4	0.6	0.7	0.9	1.1	1.4	1.6	2	2.2	2.6	2.9
											F _{MIN}

Gap Z_{MIN}=0

T-type 110/15°

15° angled application for wood doors

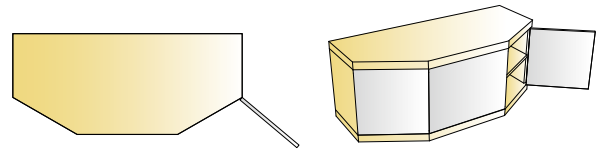
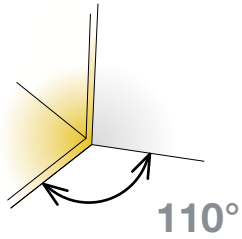

- Opening angle 110°
- Drilling diameter for hinge cup 35mm
- Drilling depth 12mm
- Hinge on plate mounting system 3Way snap-on



Technical details

Cup type	Interaxis 45mm	Interaxis 48mm
Item number	Item number	Item number
	702-0D63-650	702-0D65-650
	702-0D69-650	702-0D71-650
	702-0D75-650	702-0D77-650

Cranking
9mm

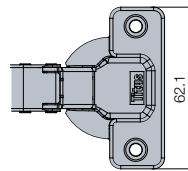
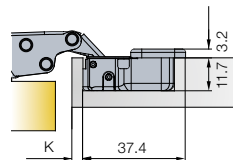
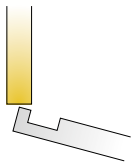

Drilling patterns for hinge cups → see page 2.17

100 Pcs

Cup made of steel, arm made of zinc

Mounting plates



Cam adjustable cruciform mounting plate
→ see page 2.81



Cruciform mounting plate
→ see page 2.83



Cam adjustable linear mounting plate
→ see page 2.81



Face frame adapter plate
→ see page 2.83

Hinge cup screws If not pre-mounted

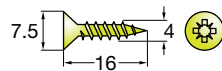

820-6328-050

10000 Pcs

Accessories



Cover caps for hinge arm
→ see page 2.177



Hinge angle restrictor
→ see page 2.175

Legend of hinge cup symbols



Screw-on ready
← screws



Machine insertion ready



EasyFix system

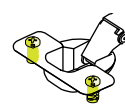
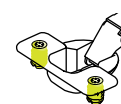
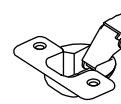

Door adjustment

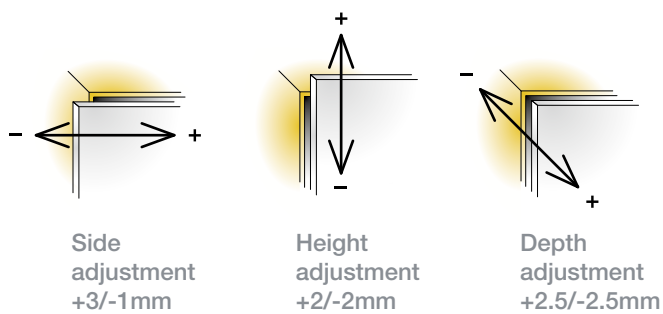

For further explanation → see pages 2.22-2.24

Mounting details

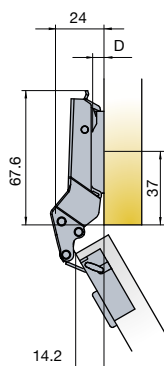

Drawings show application on D=0mm mounting plate

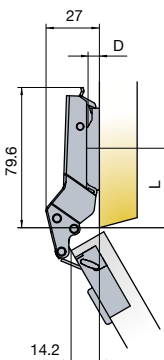

Drawings show application on D=0mm mounting plate

Mounting plate drilling distance

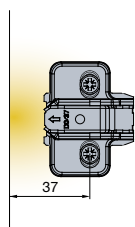
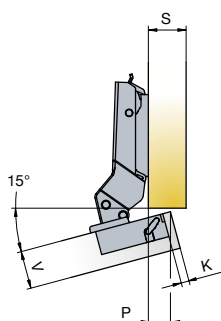

Mounting plate thickness table
For further explanation → see page 2.13

P	11	12	13	14	15	19	17	18
3	4	3	2	1	0			
4		4	3	2	1	0		
5			4	3	2	1	0	
6				4	3	2	1	0 D

X	6	7	8	9	10	11	12	13
3	4	3	2	1	0			
4		4	3	2	1	0		
5			4	3	2	1	0	
6				4	3	2	1	0 D

L=40 for thickness D=0
L=40 for thickness D=1
L=39 for thickness D=2
L=39 for thickness D=3
L=38 for thickness D=4

Soft closing system



Glissando TT
→ see page 2.189

Touch opening



PushOpen Solutions
→ see pages 2.199-2.204

Door clearance at R=1mm

For further explanation → see page 2.14

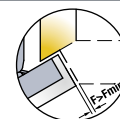

V	16	17	18	19	20	21	22	23	24	25	26
3	0.5	0.7	0.8	1	1.2	1.5	1.7	2.1	2.8	4.1	5.5
4	0.4	0.7	0.8	1	1.2	1.5	1.7	2.1	2.3	3.1	4.5
5	0.4	0.6	0.7	0.9	1.1	1.4	1.6	2	2.2	2.6	3.5
6	0.4	0.6	0.7	0.9	1.1	1.4	1.6	2	2.2	2.6	2.9 F _{MIN}

Gap Z_{MIN}=0

T-type 110/30°

30° angled application for wood doors

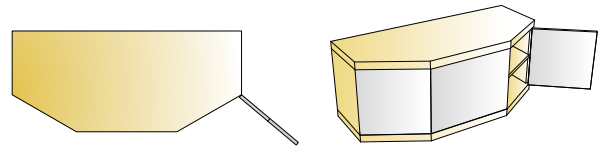
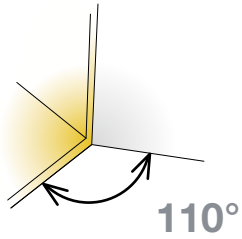

- Opening angle 110°
- Drilling diameter for hinge cup 35mm
- Drilling depth 12mm
- Hinge on plate mounting system 3Way snap-on



Technical details

Cup type	Interaxis 45mm	Interaxis 48mm
Item number	Item number	Item number
	702-0E51-650	702-0E53-650
	702-0E57-650	702-0E59-650
	702-0E63-650	702-0E65-650

Drilling patterns for hinge cups → see page 2.17

Cranking 9mm

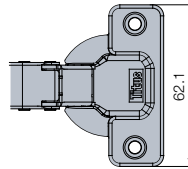
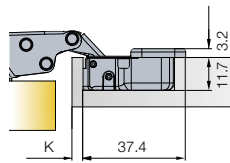
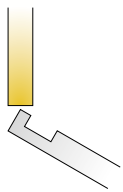

100 Pcs

Cup made of steel, arm made of zinc

Mounting plates



Cam adjustable cruciform mounting plate
→ see page 2.81



Cruciform mounting plate
→ see page 2.83



Cam adjustable linear mounting plate
→ see page 2.81



Face frame adapter plate
→ see page 2.83

Hinge cup screws If not pre-mounted

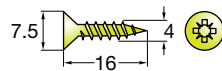

820-6328-050

10000 Pcs

Accessories



Cover caps for hinge arm
→ see page 2.177



Hinge angle restrictor
→ see page 2.175

Legend of hinge cup symbols

Screw-on ready
← screws

Machine insertion ready

EasyFix system

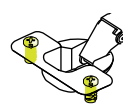
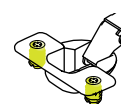
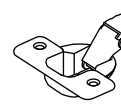

Door adjustment

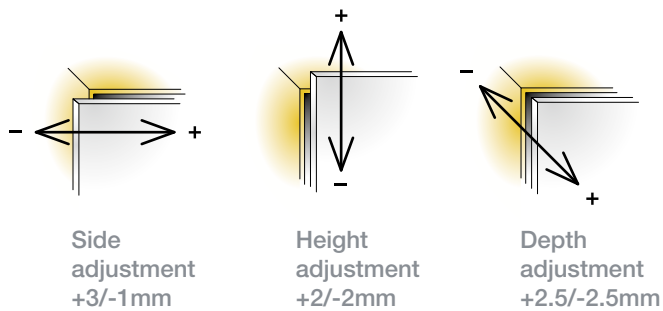

For further explanation → see pages 2.22-2.24

Mounting details

Mounting plate drilling distance

Mounting plate thickness table
For further explanation → see page 2.13

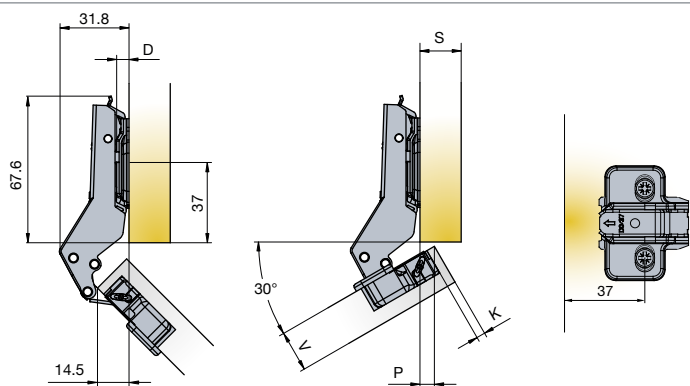

Drawings show application on D=0mm mounting plate

P	1.5	2.5	3.5	4.5	5.5	6.5	7.5	8.5
3	4	3	2	1	0			
4		4	3	2	1	0		
5			4	3	2	1	0	
6				4	3	2	1	0

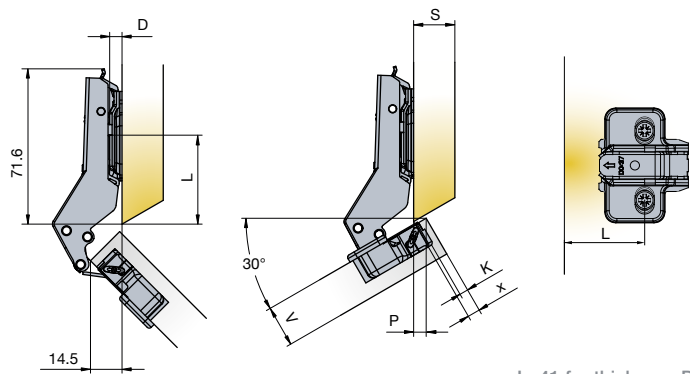

Drawings show application on D=0mm mounting plate

P	2	3	4	5	6	7	8	9
3	4	3	2	1	0			
4		4	3	2	1	0		
5			4	3	2	1	0	
6				4	3	2	1	0

L=41 for thickness D=0
L=41 for thickness D=1
L=40 for thickness D=2
L=40 for thickness D=3
L=39 for thickness D=4

Soft closing system



Glissando TT
→ see page 2.189

Touch opening



PushOpen Solutions
→ see pages 2.199-2.204

Door clearance at R=1mm

For further explanation → see page 2.14

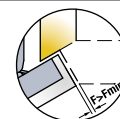

V	16	17	18	19	20	21	22	23	24	25	26
3	0.5	0.7	0.8	1	1.2	1.5	1.7	2.1	2.8	4.1	5.5
4	0.4	0.7	0.8	1	1.2	1.5	1.7	2.1	2.3	3.1	4.5
5	0.4	0.6	0.7	0.9	1.1	1.4	1.6	2	2.2	2.6	3.5
6	0.4	0.6	0.7	0.9	1.1	1.4	1.6	2	2.2	2.6	2.9

Gap Z_{MIN}=0

T-type 110/45°

45° angled application for wood doors

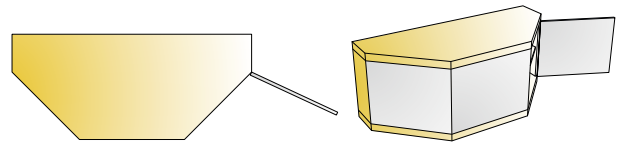
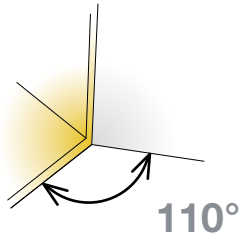

- Opening angle 110°
- Drilling diameter for hinge cup 35mm
- Drilling depth 12mm
- Hinge on plate mounting system 3Way snap-on



Technical details

Cup type	Interaxis 45mm	Interaxis 48mm
Item number	Item number	Item number
	702-0D81-650	702-0D83-650
	702-0D87-650	702-0D89-650
	702-0D97-650	702-0E18-650

Cranking
9mm

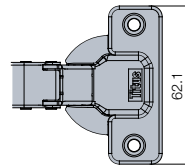
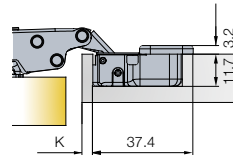
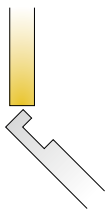

Drilling patterns for hinge cups → see page 2.17

100 Pcs

Cup made of steel, arm made of zinc

Mounting plates

- Cam adjustable cruciform mounting plate → see page 2.81
- Cruciform mounting plate → see page 2.83
- Cam adjustable linear mounting plate → see page 2.81
- Face frame adapter plate → see page 2.83

Hinge cup screws If not pre-mounted

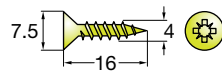

820-6328-050

10000 Pcs

Accessories

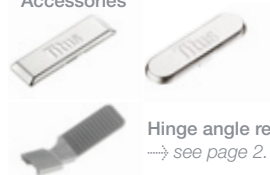

Cover caps for hinge arm → see page 2.177

Hinge angle restrictor → see page 2.175

Legend of hinge cup symbols

- Screw-on ready ← screws
- Machine insertion ready
- EasyFix system

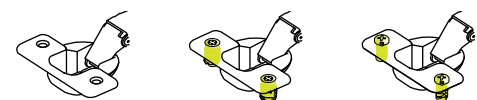

Door adjustment

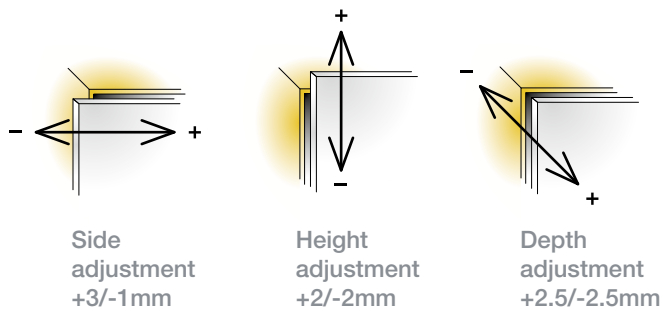

For further explanation → see pages 2.22-2.24

Mounting details

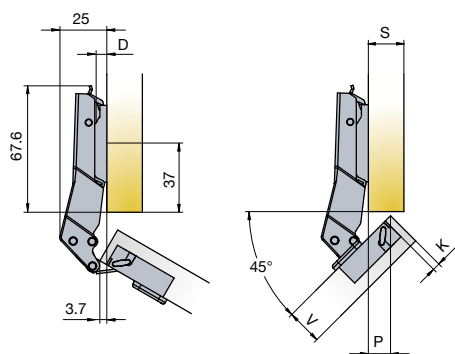

Drawings show application on D=0mm mounting plate

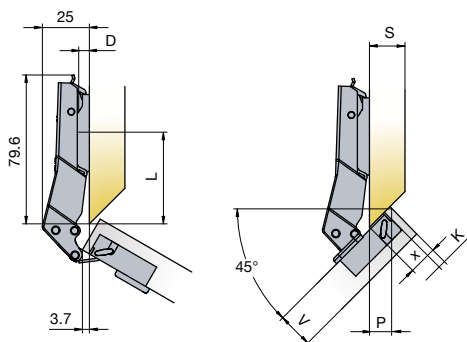

Drawings show application on D=0mm mounting plate

Mounting plate drilling distance

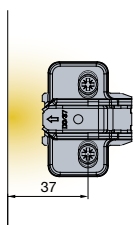

Mounting plate thickness table

For further explanation → see page 2.13

P	7	7.5	8	8.5	9	9.5	10	10.5	11	11.5	12	12.5	13	13.5
3	4		3		2		1		0					
4			4		3		2		1		0			
5				4	3		2		1		0			
6						4	3		2		1		0	

X	10	11	12	13	14	15	16	17
3	4	3	2	1	0			
4		4	3	2	1	0		
5			4	3	2	1	0	
6				4	3	2	1	0 D

L=49 for thickness D=0
 L=48 for thickness D=1
 L=47 for thickness D=2
 L=46 for thickness D=3
 L=45 for thickness D=4

Soft closing system



Glissando TT
 → see page 2.189

Touch opening



PushOpen Solutions
 → see pages 2.199-2.204

Door clearance at R=1mm

For further explanation → see page 2.14

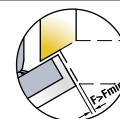

V	16	17	18	19	20	21	22	23	24	25	26
3	0.5	0.7	0.8	1	1.2	1.5	1.7	2.1	2.8	4.1	5.5
4	0.4	0.7	0.8	1	1.2	1.5	1.7	2.1	2.3	3.1	4.5
5	0.4	0.6	0.7	0.9	1.1	1.4	1.6	2	2.2	2.6	3.5
6	0.4	0.6	0.7	0.9	1.1	1.4	1.6	2	2.2	2.6	2.9 F _{MIN}

Gap Z_{MIN}=0

T-type 110/45°

45° angled application for wood doors

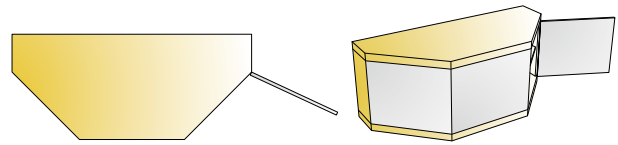
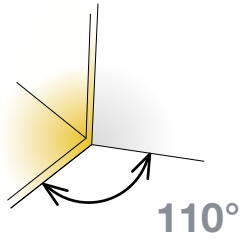

- Opening angle 110°
- Drilling diameter for hinge cup 35mm
- Drilling depth 12mm
- Hinge on plate mounting system 3Way snap-on



Technical details

Cup type	Interaxis 45mm	Interaxis 48mm
Item number	Item number	Item number
	702-0B07-650	702-0B09-650
	702-0C77-650	702-0C79-650
	702-0C53-650	702-0C55-650

Drilling patterns for hinge cups → see page 2.17

Cranking
17mm

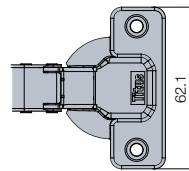
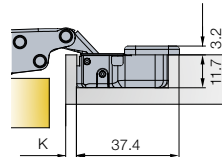
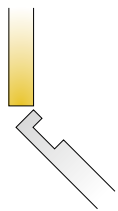

100 Pcs

Cup made of steel, arm made of zinc

Mounting plates



Cam adjustable cruciform mounting plate
→ see page 2.81



Cruciform mounting plate
→ see page 2.83



Cam adjustable linear mounting plate
→ see page 2.81



Face frame adapter plate
→ see page 2.83

Hinge cup screws

If not pre-mounted

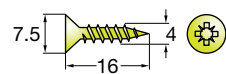

820-6328-050

10000 Pcs

Accessories



Cover caps for hinge arm
→ see page 2.177



Hinge angle restrictor
→ see page 2.175

Legend of hinge cup symbols



Screw-on ready
← screws



Machine insertion ready



EasyFix system

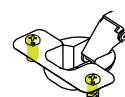
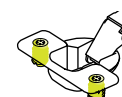

Door adjustment

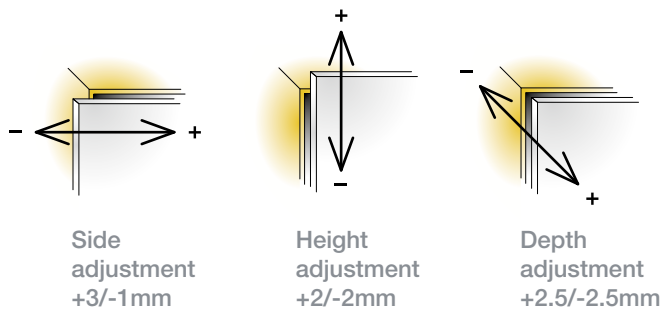

For further explanation → see pages 2.22-2.24

Mounting details

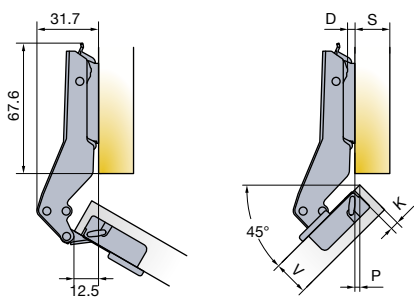

Drawings show application on D=0mm mounting plate

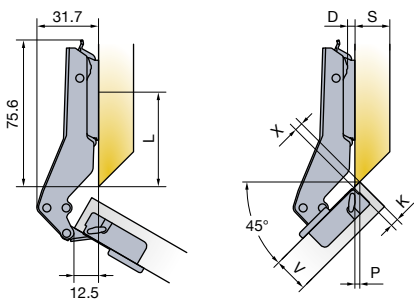

Drawings show application on D=0mm mounting plate

Mounting plate drilling distance

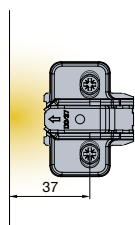

Mounting plate thickness table
For further explanation → see page 2.13

P	0	0.5	1	1.5	2	2.5	3	3.5	4
3		2		1		0			
4	3		2		1		0		
5		3		2		1		0	
6	4		3		2		1		0

X 0 0.5 1 1.5 2 2.5 3 3.5 4 4.5 5 6

3	2		1			0					
4		2			1			0			
5		3			2		1			0	
6	4		3			2		1			0

L=45 for thickness D=0
L=44 for thickness D=1
L=43 for thickness D=2
L=42 for thickness D=3
L=41 for thickness D=4

Soft closing system



Glissando TT
→ see page 2.189

Touch opening



PushOpen Solutions
→ see pages 2.199-2.204

Door clearance at R=1mm

For further explanation → see page 2.14

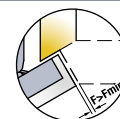

V	16	17	18	19	20	21	22	23	24	25	26
3	0.5	0.7	0.8	1	1.2	1.5	1.7	2.1	2.8	4.1	5.5
4	0.4	0.7	0.8	1	1.2	1.5	1.7	2.1	2.3	3.1	4.5
5	0.4	0.6	0.7	0.9	1.1	1.4	1.6	2	2.2	2.6	3.5
6	0.4	0.6	0.7	0.9	1.1	1.4	1.6	2	2.2	2.6	2.9

Gap Z_{MIN}=0

T-type 110/90°

For wood door cabinets with blind panels

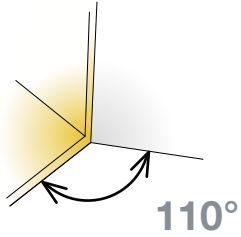
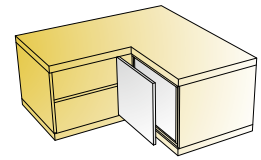

- Opening angle 110°
- Drilling diameter for hinge cup 35mm
- Drilling depth 12mm
- Hinge on plate mounting system 3Way snap-on



Technical details

Cup type	Interaxis 45mm	Interaxis 48mm
Item number	Item number	Item number
	702-0A95-650	702-0A97-650
	702-0D35-650	702-0D37-650
	702-0D29-650	702-0D31-650

Cranking
17mm

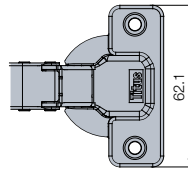
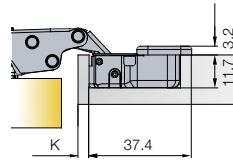
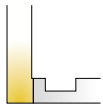

Drilling patterns for hinge cups → see page 2.17

100 Pcs

Cup made of steel, arm made of zinc

Mounting plates



Cam adjustable cruciform mounting plate
→ see page 2.81



Cruciform mounting plate
→ see page 2.83



Cam adjustable linear mounting plate
→ see page 2.81



Face frame adapter plate
→ see page 2.83

Hinge cup screws

If not pre-mounted

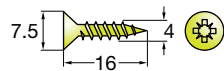

820-6328-050

10000 Pcs

Accessories



Cover caps for hinge arm
→ see page 2.177



Hinge angle restrictor
→ see page 2.175

Legend of hinge cup symbols



Screw-on ready
← screws



Machine insertion ready



EasyFix system

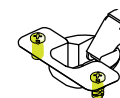
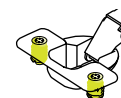
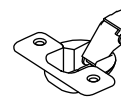

Door adjustment

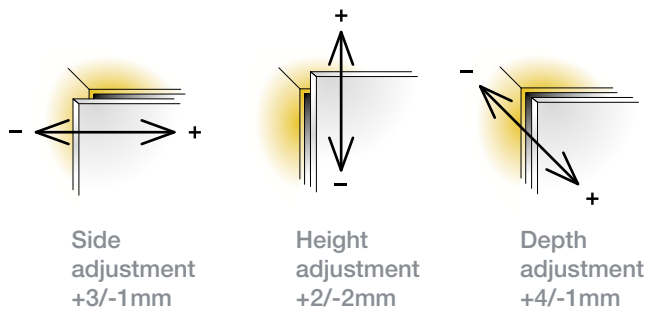

For further explanation → see pages 2.22-2.24

Mounting details

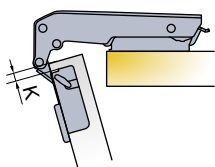

Drawing shows application on D=2mm mounting plate

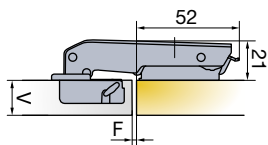

Drawing shows application on D=2mm mounting plate

Mounting plate drilling distance

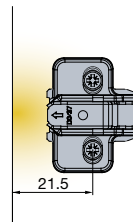

Soft closing system



Glissando TT
→ see page 2.189

Touch opening



PushOpen Solutions
→ see pages 2.199-2.204

Door clearance at R=1mm

For further explanation → see page 2.14

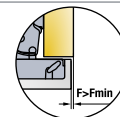

V	16	17	18	19	20	21	22	23	24	25	26
3	0.5	0.7	0.8	1	1.2	1.5	1.7	2.1	2.8	4.1	5.5
4	0.4	0.7	0.8	1	1.2	1.5	1.7	2.1	2.3	3.1	4.5
K											
5	0.4	0.6	0.7	0.9	1.1	1.4	1.6	2	2.2	2.6	3.5
6	0.4	0.6	0.7	0.9	1.1	1.4	1.6	2	2.2	2.6	2.9 F _{MIN}

Gap Z_{MIN}=0

T-type 120

For wood doors

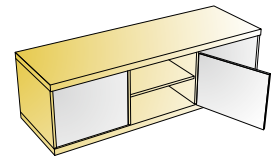
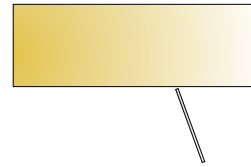
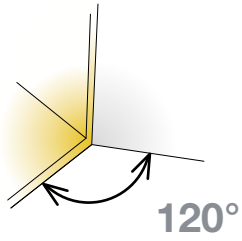

- Opening angle
- Drilling diameter for hinge cup
- Drilling depth
- Hinge on plate mounting system

120°
35mm
12mm
3Way snap-on



Technical details

Cup type	Interaxis 45mm	Interaxis 48mm
Item number	Item number	Item number
	702-0UK0-054	702-0UL0-054
	702-0UK1-054	702-0UL1-054
	702-0UK4-054	702-0UL4-054

Cranking
0mm

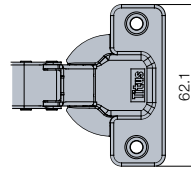
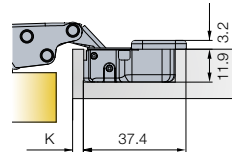
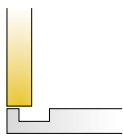

Drilling patterns for hinge cups → see page 2.17

150 Pcs

Made of steel

Mounting plates



Cam adjustable cruciform mounting plate
→ see page 2.81



Cruciform mounting plate
→ see page 2.83



Cam adjustable linear mounting plate
→ see page 2.81



Face frame adapter plate
→ see page 2.83

Hinge cup screws If not pre-mounted

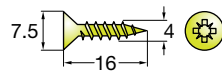

820-6328-050

10000 Pcs

Accessories



Cover caps for hinge arm
→ see page 2.177

Legend of hinge cup symbols



Screw-on ready
← screws



Machine insertion ready



EasyFix system

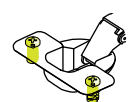
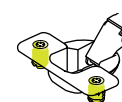
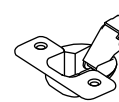

Door adjustment

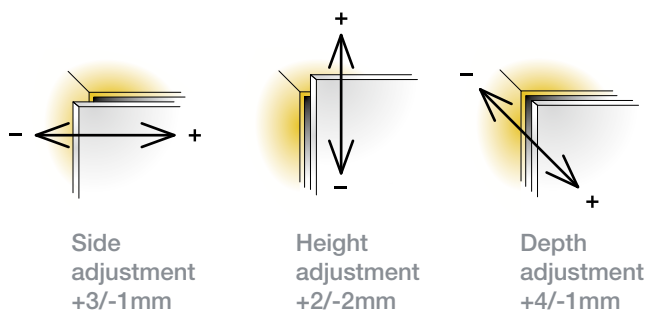

For further explanation → see pages 2.22-2.24

Mounting details

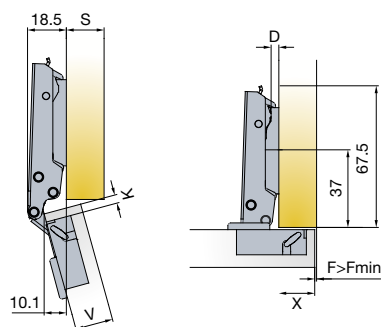

Drawings show application on D=0mm mounting plate

Mounting plate drilling distance

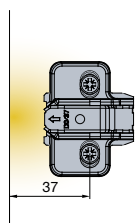

Mounting plate thickness table

For further explanation → see page 2.13

X	13	14	15	16	17	18	19
3	3	2	1	0			
4	4	3	2	1	0		
K		4	3	2	1	0	
6			4	3	2	1	0

$D=13+K-X$

Soft closing systems



Glissando TT
→ see page 2.189



Glissando CR
→ see page 2.195

Touch opening



PushOpen Solutions
→ see pages 2.199-2.204

Door clearance at R=1mm

For further explanation → see page 2.14

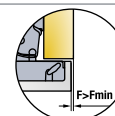

V	16	17	18	19
3	1.1	0.4	0	0
K	2	1.4	0.7	0.1
5	3	2.3	1.6	1

Gap Z_{MIN} =2

T-type 95 Thick Door Hinge

For wood doors

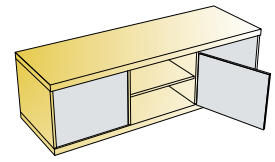
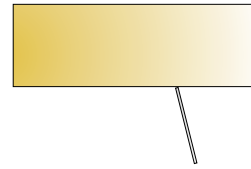
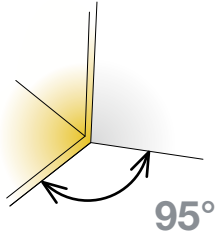

- Opening angle
- Drilling diameter for hinge cup
- Drilling depth
- Hinge on plate mounting system

95°
35mm
12mm
3Way snap-on



Technical details

Cup type	Interaxis 45mm	Interaxis 48mm
	Item number	Item number

Cranking
0mm

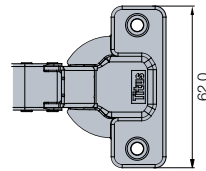
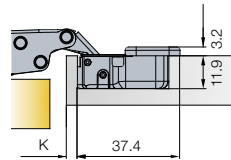
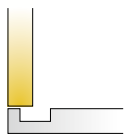

	707-0XK0-054	707-0XL0-054
	707-0XK1-054	707-0XL1-054
	707-0XK4-054	707-0XL4-054

Drilling patterns for hinge cups → see page 2.17

150 Pcs

Made of steel

Cranking
5mm

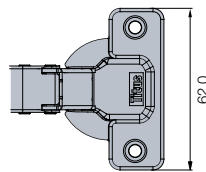
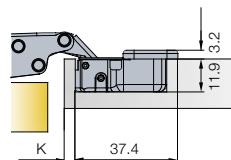
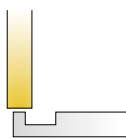

	707-0YK0-054	707-0YL0-054
	707-0YK1-054	707-0YL1-054
	707-0YK4-054	707-0YL4-054

Drilling patterns for hinge cups → see page 2.17

150 Pcs

Made of steel

Mounting plates



Cam adjustable cruciform mounting plate
→ see page 2.81



Cruciform mounting plate
→ see page 2.83



Cam adjustable linear mounting plate
→ see page 2.81



Face frame adapter plate
→ see page 2.83

Hinge cup screws If not pre-mounted

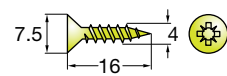

820-6328-050
 10000 Pcs

Accessories



Cover caps for hinge arm
→ see page 2.177

Touch opening



PushOpen Solutions
→ see pages 2.199-2.204

Legend of hinge cup symbols

Screw-on ready
← screws

Machine insertion ready

EasyFix system

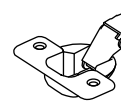

Soft closing systems
Glissando TT



→ see page 2.189

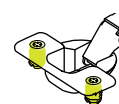

Glissando CR



→ see page 2.195

Door adjustment

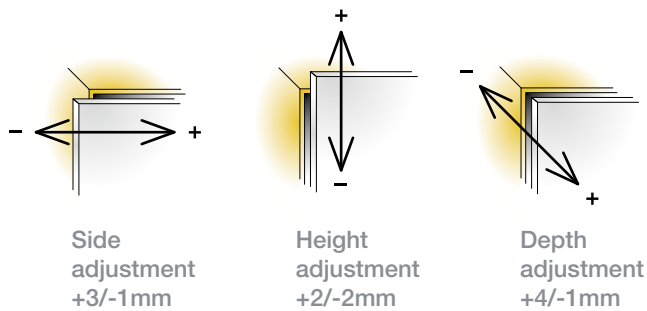

For further explanation → see pages 2.22-2.24

Mounting details

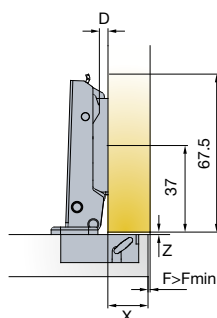
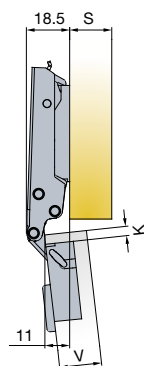

Drawings show application on D=0mm mounting plate

Mounting plate drilling distance

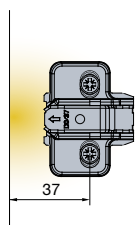

Mounting plate thickness table

For further explanation → see page 2.13

X	13	14	15	16	17	18	19	20	21	22
3	3	2	1	0						
4	4	3	2	1	0					
5		4	3	2	1	0				
K 6			4	3	2	1	0			
7				4	3	2	1	0		
8					4	3	2	1	0	
9						4	3	2	1	0

$D=13+K-X$

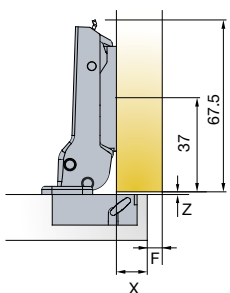
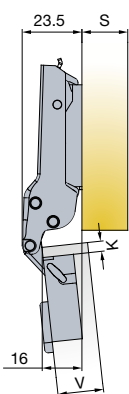

Drawings show application on D=0mm mounting plate

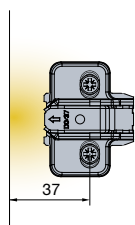

X	8	9	10	11	12	13	14	15	16	17
3	3	2	1	0						
4	4	3	2	1	0					
5		4	3	2	1	0				
K 6			4	3	2	1	0			
7				4	3	2	1	0		
8					4	3	2	1	0	
9						4	3	2	1	0

$D=8+K-X$

Gap Z

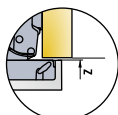

V	20	22	24	26	28	30	32	34
3	0	0	0	0	0	0	0	0
4	0	0	0	0	0	0	0	0
5	0	0	0	0	0	0	0	0
K 6	0	0	0	0	0	0	0	0
7	0	0	0	0	0	0	0	0
8	0	0	0	0	0	0	0	0
9	0	0	1.6	1.7	1.8	2.0	2.1	2.3

Z_{MIN}

Door clearance at R=1mm

For further explanation → see page 2.14

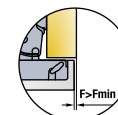

V	20	22	24	26	28	30	32	34
3	0.6	0.9	1.3	1.7	2.2	4.0	5.9	7.8
4	0.6	0.9	1.2	1.7	2.2	3.4	5.2	7.1
5	0.6	0.9	1.2	1.6	2.1	2.9	4.6	6.5
K 6	0.6	0.9	1.2	1.5	2.1	2.6	4.1	5.9
7	0.6	0.9	1.2	1.5	2.1	2.6	3.6	5.3
8	0.6	0.8	1.2	1.5	2.0	2.5	3.2	4.8
9	0.6	0.8	1.2	1.5	2.0	2.5	3.1	4.4

F_{MIN}

T-type 95 Thick Door Hinge

For wood doors

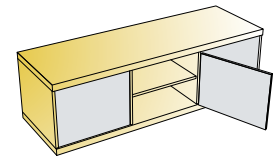
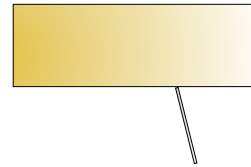
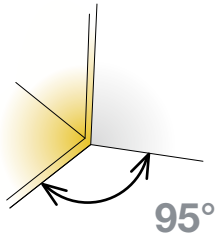

- Opening angle
- Drilling diameter for hinge cup
- Drilling depth
- Hinge on plate mounting system

95°
35mm
12mm
3Way snap-on



Technical details

Cup type	Interaxis 45mm	Interaxis 48mm
	Item number	Item number

Cranking
9mm

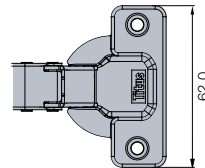
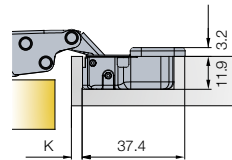
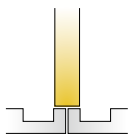

	707-0ZK0-054	707-0ZL0-054
	707-0ZK1-054	707-0ZL1-054
	707-0ZK4-054	707-0ZL4-054

Drilling patterns for hinge cups → see page 2.17

150 Pcs

Made of steel

Cranking
17mm

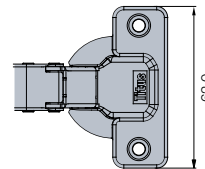
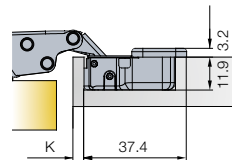
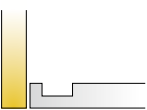

	707-0WK0-054	707-0WL0-054
	707-0WK1-054	707-0WL1-054
	707-0WK4-054	707-0WL4-054

Drilling patterns for hinge cups → see page 2.17

150 Pcs

Made of steel

Mounting plates



Cam adjustable cruciform mounting plate
→ see page 2.81



Cruciform mounting plate
→ see page 2.83



Cam adjustable linear mounting plate
→ see page 2.81



Face frame adapter plate
→ see page 2.83

Hinge cup screws

If not pre-mounted

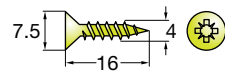

820-6328-050
 10000 Pcs

Accessories



Cover caps for hinge arm
→ see page 2.177

Touch opening



PushOpen Solutions
→ see pages 2.199-2.204

Legend of hinge cup symbols

Screw-on ready
← screws

Machine insertion ready

EasyFix system

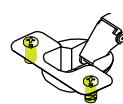
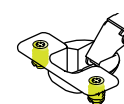
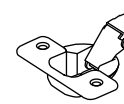

Soft closing systems

Glissando TT



→ see page 2.189

Glissando CR



→ see page 2.195

Door adjustment

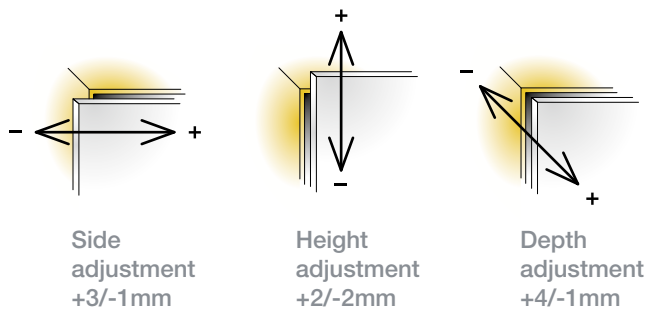

For further explanation → see pages 2.22-2.24

Mounting details

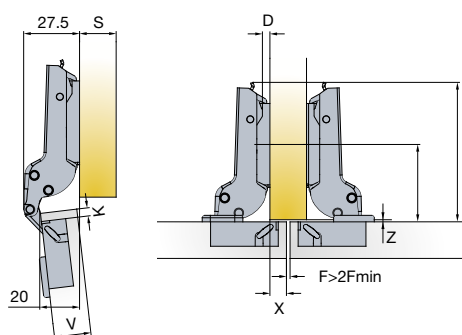

Drawings show application on D=0mm mounting plate

Mounting plate drilling distance

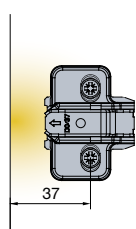

Mounting plate thickness table

For further explanation → see page 2.13

X	4	5	6	7	8	9	10	11	12	13
3	3	2	1	0						
4	4	3	2	1	0					
5		4	3	2	1	0				
K 6			4	3	2	1	0			
7				4	3	2	1	0		
8					4	3	2	1	0	
9						4	3	2	1	0

$D=4+K-X$

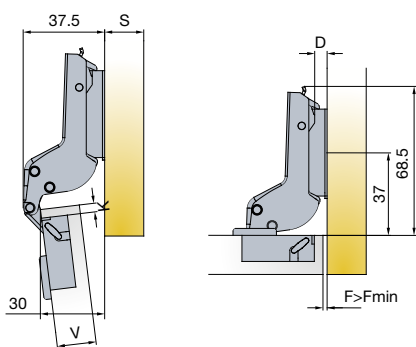

Drawings show application on D=2mm mounting plate

V	20	22	24	26	28	30	32
3	0	0	1	1	2	3	4*
4	1	1	2	2	3	4	4*
K 5	2	2	3	3	4	4	4*
6	3	3	4	4	4*	4*	
7	4	4	4*	4*	4*	4*	D

$D=-4+K+F$

*Hinge adjustment needed

Gap Z

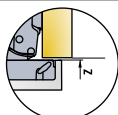

V	20	22	24	26	28	30	32	34
3	0	0	0	0	0	0	0	0
4	0	0	0	0	0	0	0	0
5	0	0	0	0	0	0	0	0
K 6	0	0	0	0	0	0	0	0
7	0	0	0	0	0	0	0	0
8	0	0	0	0	0	0	0	0
9	0	0	1.6	1.7	1.8	2.0	2.1	2.3

Z_{MIN}

Door clearance at R=1mm

For further explanation → see page 2.14

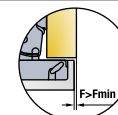

V	20	22	24	26	28	30	32	34
3	0.6	0.9	1.3	1.7	2.2	4.0	5.9	7.8
4	0.6	0.9	1.2	1.7	2.2	3.4	5.2	7.1
5	0.6	0.9	1.2	1.6	2.1	2.9	4.6	6.5
K 6	0.6	0.9	1.2	1.5	2.1	2.6	4.1	5.9
7	0.6	0.9	1.2	1.5	2.1	2.6	3.6	5.3
8	0.6	0.8	1.2	1.5	2.0	2.5	3.2	4.8
9	0.6	0.8	1.2	1.5	2.0	2.5	3.1	4.4

F_{MIN}

T-type 110 Unsprung Hinge

For wood doors

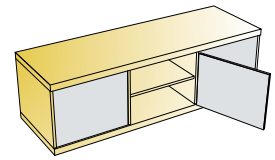
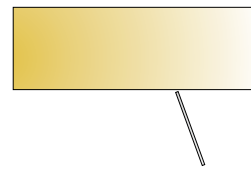
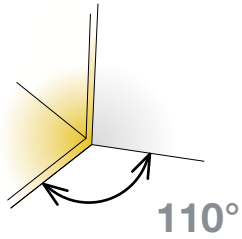

- Opening angle
- Drilling diameter for hinge cup
- Drilling depth
- Hinge on plate mounting system

110°
35mm
12mm
3Way snap-on



Technical details

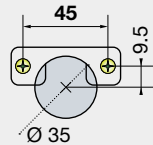
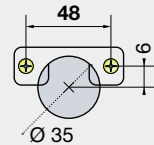

	Interaxis 45mm	Interaxis 48mm
Cup type	 Ø 35	 Ø 35
Item number	704-0593-054	704-0672-054
Item number		704-0553-054

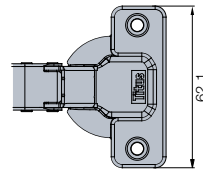
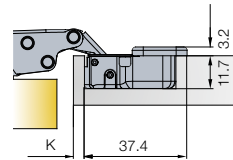
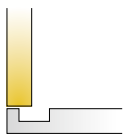
Cranking
0mm



150 Pcs

Made of steel

	704-0593-054	704-0672-054
		704-0553-054

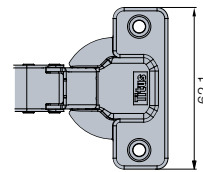
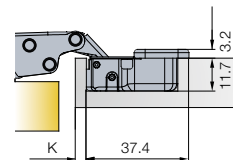
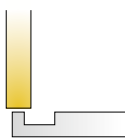

Drilling patterns for hinge cups → see page 2.17

Cranking
5mm



150 Pcs

Made of steel

	704-0661-054	704-0673-054
		704-0604-054

Drilling patterns for hinge cups → see page 2.17

Mounting plates



Cam adjustable cruciform mounting plate
→ see page 2.81



Cruciform mounting plate
→ see page 2.83



Cam adjustable linear mounting plate
→ see page 2.81



Face frame adapter plate
→ see page 2.83

Hinge cup screws

If not pre-mounted



820-6328-050

10000 Pcs

Accessories



Cover caps for hinge arm
→ see pages 2.177



Hinge angle restrictor
→ see page 2.175

Legend of hinge cup symbols

Screw-on ready
← screws

EasyFix system

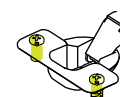

· Concealed hinge without spring for use with PushOpen mechanisms with magnet

→ see pages 2.199-2.204

Door adjustment

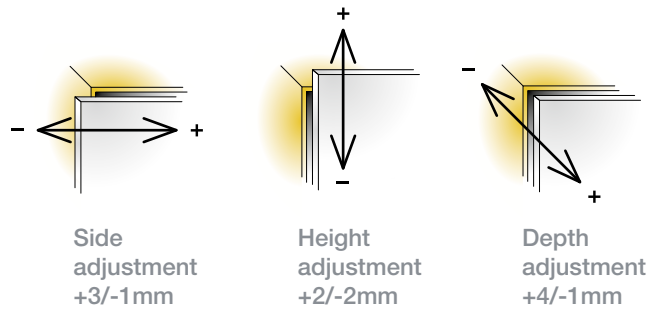

For further explanation → see pages 2.22-2.24

Mounting details

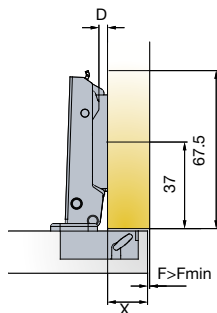
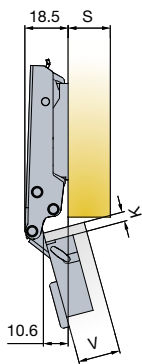

Mounting plate drilling distance

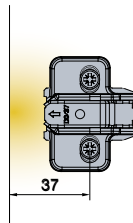

Mounting plate thickness table

For further explanation → see page 2.13

X	13	14	15	16	17	18	19
3	3	2	1	0			
4	4	3	2	1	0		
K							
5		4	3	2	1	0	
6			4	3	2	1	0
							D

$D=13+K-X$

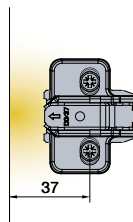
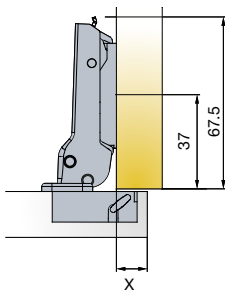
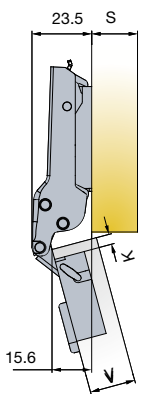

X	8	9	10	11	12	13	14
3	3	2	1	0			
4	4	3	2	1	0		
K							
5		4	3	2	1	0	
6			4	3	2	1	0
							D

$D=8+K-X$

Touch opening



PushOpen Solutions

→ see pages 2.199-2.204

Door clearance at R=1mm

For further explanation → see page 2.14

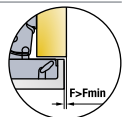

V	16	17	18	19	20	21	22	23	24	25	26
3	0.5	0.7	0.8	1	1.2	1.5	1.7	2.1	2.8	4.1	5.5
4	0.4	0.7	0.8	1	1.2	1.5	1.7	2.1	2.3	3.1	4.5
K											
5	0.4	0.6	0.7	0.9	1.1	1.4	1.6	2	2.2	2.6	3.5
6	0.4	0.6	0.7	0.9	1.1	1.4	1.6	2	2.2	2.6	2.9
											F _{MIN}

Gap Z_{MIN}=0

T-type 110 Unsprung Hinge

For wood doors

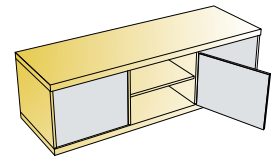
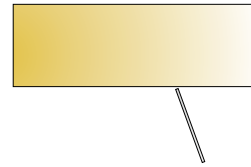
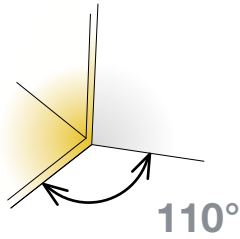

- Opening angle
- Drilling diameter for hinge cup
- Drilling depth
- Hinge on plate mounting system

110°
35mm
12mm
3Way snap-on

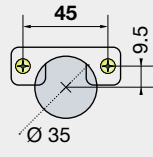
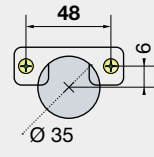

Technical details

	Interaxis 45mm	Interaxis 48mm
Cup type	 Ø 35	 Ø 35
Item number	704-0595-054	704-0674-054
Item number		704-0697-054

Cranking
9mm

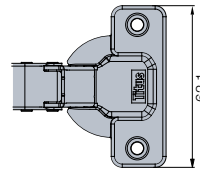
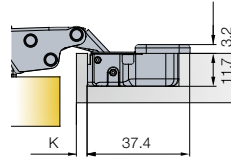
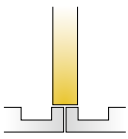

Drilling patterns for hinge cups → see page 2.17

 150 Pcs

Made of steel

Mounting plates

 Cam adjustable cruciform mounting plate
→ see page 2.81

 Cruciform mounting plate
→ see page 2.83

 Cam adjustable linear mounting plate
→ see page 2.81

 Face frame adapter plate
→ see page 2.83

Hinge cup screws If not pre-mounted

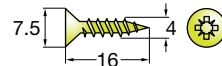

820-6328-050

 10000 Pcs

Accessories



Cover caps for hinge arm
→ see page 2.177



Hinge angle restrictor
→ see page 2.175

Legend of hinge cup symbols

 Screw-on ready
← screws

 EasyFix system

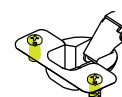

· Concealed hinge without spring for use with PushOpen mechanisms with magnet

→ see pages 2.199-2.204

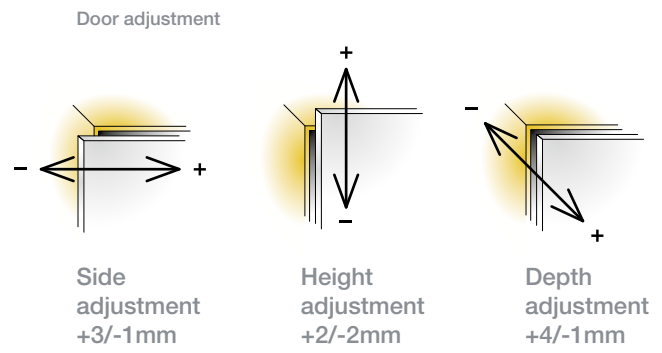

For further explanation → see pages 2.22-2.24

Mounting details

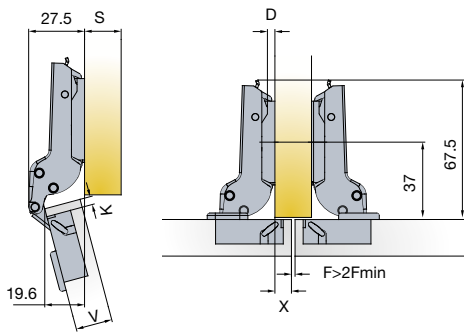

Mounting plate drilling distance

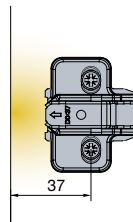

Mounting plate thickness table

For further explanation → see page 2.13

X	4	5	6	7	8	9	10
3	3	2	1	0			
4	4	3	2	1	0		
5		4	3	2	1	0	
6			4	3	2	1	0

$D=4+K-X$

Touch opening



PushOpen Solutions
→ see pages 2.199-2.204

Door clearance at R=1mm

For further explanation → see page 2.14

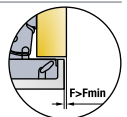

V	16	17	18	19	20	21	22	23	24	25	26
3	0.5	0.7	0.8	1	1.2	1.5	1.7	2.1	2.8	4.1	5.5
4	0.4	0.7	0.8	1	1.2	1.5	1.7	2.1	2.3	3.1	4.5
5	0.4	0.6	0.7	0.9	1.1	1.4	1.6	2	2.2	2.6	3.5
6	0.4	0.6	0.7	0.9	1.1	1.4	1.6	2	2.2	2.6	2.9 F _{MIN}

Gap Z_{MIN}=0

T-type 170

For wood doors

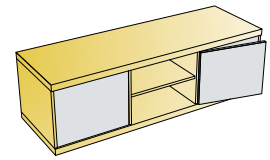
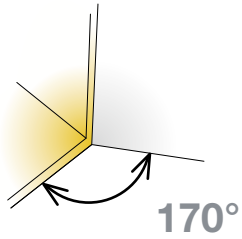

- Opening angle
- Drilling diameter for hinge cup
- Drilling depth
- Hinge on plate mounting system

165°
35mm
12mm
3Way snap-on



Technical details

	Interaxis 45mm	Interaxis 48mm
Cup type	Item number	Item number

Cranking
0mm

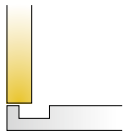

	702-0EK0-054	702-0EL0-054
	702-0EK1-054	702-0EL1-054
	702-0EK4-054	702-0EL4-054

Drilling patterns for hinge cups → see page 2.17

50 Pcs

Made of steel and zinc

Mounting plates



Cam adjustable cruciform mounting plate
→ see page 2.81



Cruciform mounting plate
→ see page 2.83



Cam adjustable linear mounting plate
→ see page 2.81



Face frame adapter plate
→ see page 2.83

Hinge cup screws

If not pre-mounted

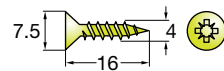

820-6328-050

10000 Pcs

Accessories



Hinge angle restrictor
→ see page 2.175

Legend of hinge cup symbols



Screw-on ready
← screws



Machine insertion ready



EasyFix system

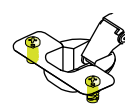
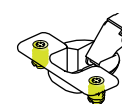
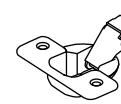

Door adjustment

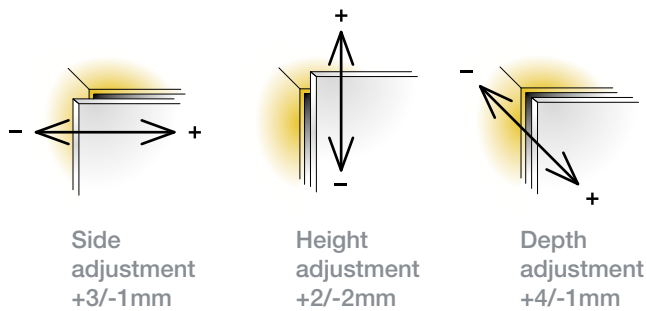

For further explanation → see pages 2.22-2.24

Mounting details

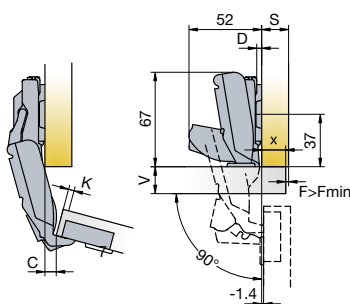

Drawings show application on D=0mm mounting plate
No door protrusion in 90° position

Mounting plate drilling distance

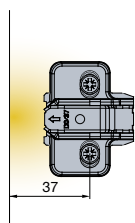

Mounting plate thickness table

For further explanation → see page 2.13

X	13	14	15	16	17	18	19
3	3	2	1	0			
4	4	3	2	1	0		
5		4	3	2	1	0	
6			4	3	2	1	0

$D=13+K-X$

Soft closing systems



Glissando TL 170
→ see page 2.191



Glissando CR
→ see page 2.195

Touch opening



PushOpen Solutions
→ see pages 2.199-2.204

Door clearance at R=1mm

For further explanation → see page 2.14

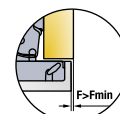

V	16	17	18	19	20	21	22	23	24
3	0.0	0.0	0.0	0.0	0.0	0.0	0.0	0.0	0.0
4	0.0	0.0	0.0	0.0	0.0	0.0	0.0	0.0	0.0
K 5	0.0	0.0	0.0	0.0	0.0	0.0	0.0	0.0	0.0
6	0.0	0.0	0.0	0.0	0.0	0.0	0.0	0.0	2.6
7	0.0	0.0	0.0	0.0	0.0	0.0	0.0	0.0	5.1

Gap Z_{MIN}=0.5

T-type 170

For wood doors

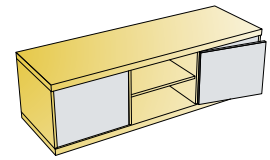
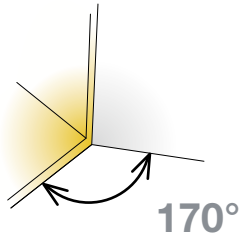

- Opening angle
- Drilling diameter for hinge cup
- Drilling depth
- Hinge on plate mounting system

165°
35mm
12mm
3Way snap-on



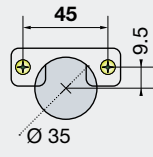
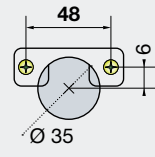

Technical details

Cup type	Interaxis 45mm	Interaxis 48mm
		
Item number	Item number	Item number

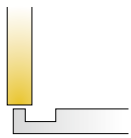
Cranking
5mm



	702-0FK0-054	702-0FL0-054
	702-0FK1-054	702-0FL1-054
	702-0FK4-054	702-0FL4-054



Drilling patterns for hinge cups → see page 2.17

 50 Pcs

Made of steel and zinc

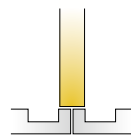
Cranking
9mm



	702-0GK0-054	702-0GL0-054
	702-0GK1-054	702-0GL1-054
	702-0GK4-054	702-0GL4-054

Drilling patterns for hinge cups → see page 2.17

 50 Pcs

Made of steel and zinc

Mounting plates



Cam adjustable cruciform mounting plate
→ see page 2.81



Cruciform mounting plate
→ see page 2.83



Cam adjustable linear mounting plate
→ see page 2.81



Face frame adapter plate
→ see page 2.83

Hinge cup screws If not pre-mounted

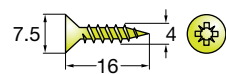

820-6328-050

 10000 Pcs

Accessories



PushOpen Solutions
→ see pages 2.199-2.204



Hinge angle restrictor
→ see page 2.175

Legend of hinge cup symbols



Screw-on ready
← screws



Machine insertion ready



EasyFix system

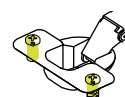
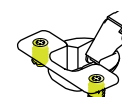

Door adjustment

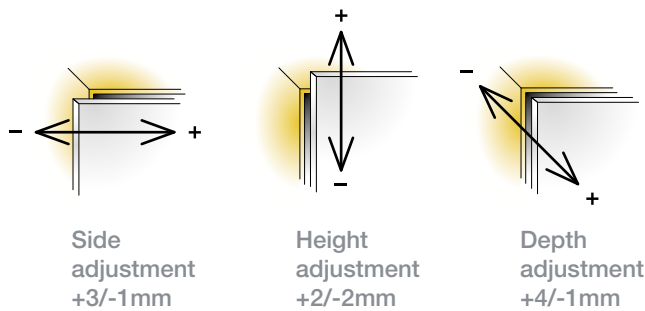

For further explanation → see pages 2.22-2.24

Mounting details

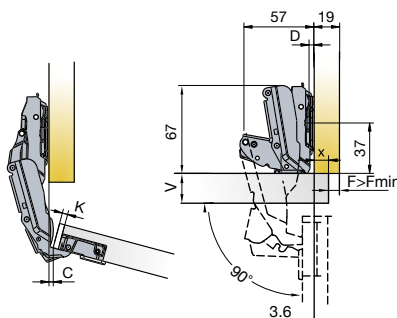

Drawings show application on D=0mm mounting plate

Mounting plate drilling distance

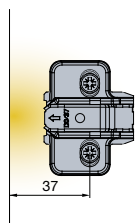

Mounting plate thickness table

For further explanation → see page 2.13

X	8	9	10	11	12	13	14
3	3	2	1	0			
4	4	3	2	1	0		
K	5	4	3	2	1	0	
6		4	3	2	1	0	D

$D=8+K-X$

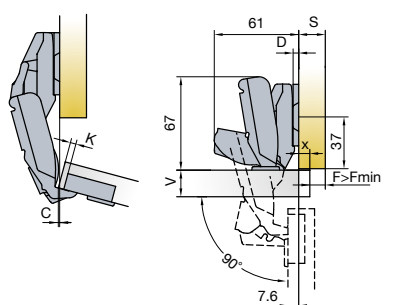

Drawings show application on D=0mm mounting plate

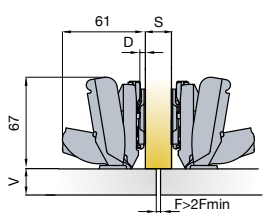

Drawing show application on D=0mm mounting plate

X 1 2 3 4 5 6 7 8 9 10 11

3	6		3	2	1	0					
4		6		3	2	1	0				
K	5		6		3	2	1	0			
6			6		3	2	1	0			
7				6		3	2	1	0	D	

$D=4+K-X$

Soft closing systems



Glissando TL 170
→ see page 2.197



Glissando CR
→ see page 2.195

Touch opening



PushOpen Solutions
→ see pages 2.199-2.204

Door clearance at R=1mm

For further explanation → see page 2.14

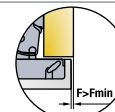

V	16	17	18	19	20	21	22	23	24
3	0.0	0.0	0.0	0.0	0.0	0.0	0.0	0.0	0.0
4	0.0	0.0	0.0	0.0	0.0	0.0	0.0	0.0	0.0
K	5	0.0	0.0	0.0	0.0	0.0	0.0	0.0	0.0
6	0.0	0.0	0.0	0.0	0.0	0.0	0.0	0.0	2.6
7	0.0	0.0	0.0	0.0	0.0	0.0	0.0	0.0	5.1

Gap Z_{MIN}=0.5

T-type for Pie-cut Corner Cabinet

For wood doors

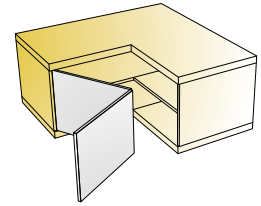

- Opening angle 70°
- Drilling diameter for hinge cup 35mm
- Drilling depth 11mm
- Hinge on plate mounting system 3Way snap-on



	Interaxis 45mm	Interaxis 48mm
Cup type	Item number	Item number
	721-0PK0-650	721-0PL0-650
	721-0PK4-650	721-0PL4-650

Corner cabinet

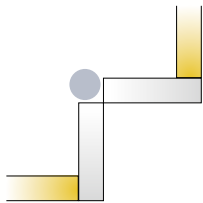

Drilling patterns for hinge cups → see page 2.17

100 Pcs Cup made of zinc, arm made of steel

Mounting plates



Cam adjustable cruciform mounting plate
→ see page 2.81



Cruciform mounting plate
→ see page 2.83



Cam adjustable linear mounting plate
→ see page 2.81

Hinge cup screws If not pre-mounted

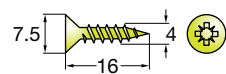

820-6328-050

10000 Pcs

Accessories



Cover caps for hinge arm
→ see page 2.177

Legend of hinge cup symbols

Screw-on ready
← screws

EasyFix

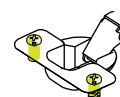

Door adjustment

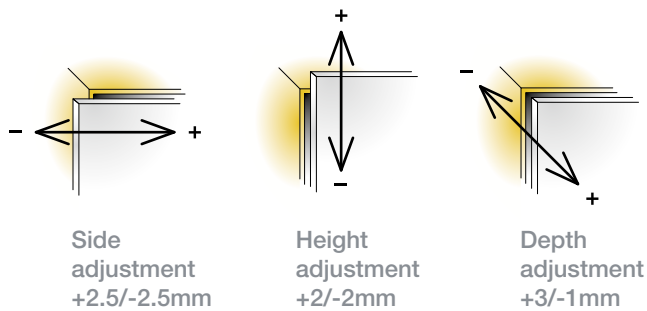

For further explanation → see pages 2.22-2.24

Mounting details

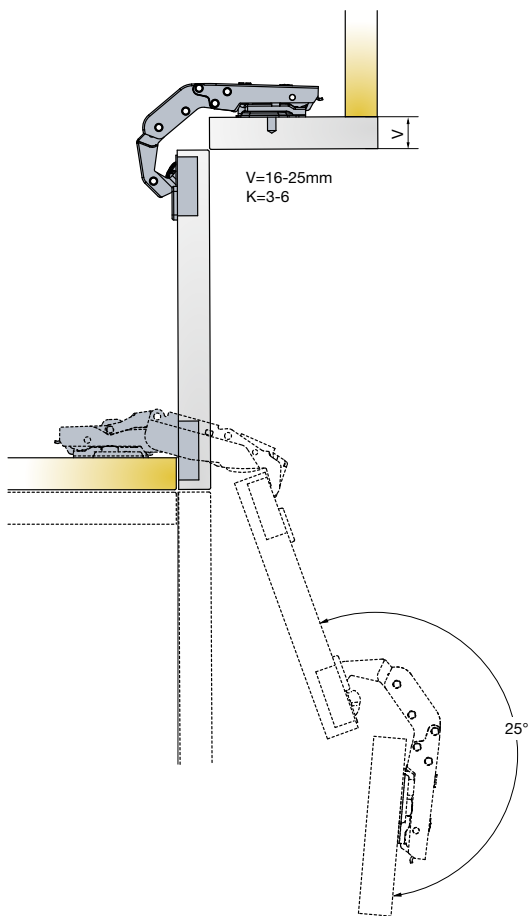

Mounting plate drilling distance

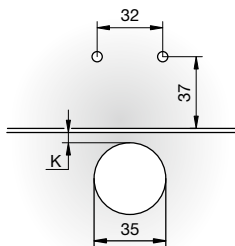

Any T-type mounting plate can be used

Adjustments

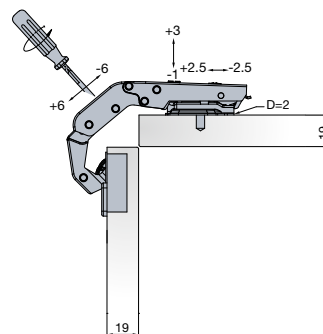

The adjustment of the gap between two doors is done by rotating the adjustment screw as shown on the drawing

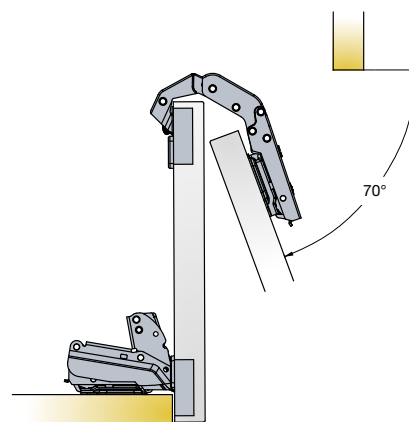

Touch opening



PushOpen Solutions
→ see pages 2.199-2.204

T-type Mounting Plates

3Way snap-on mounting

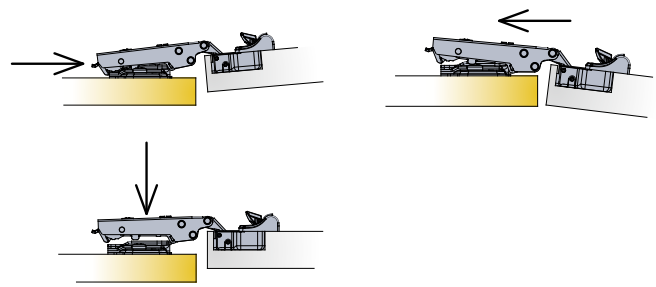

Cam adjustable cruciform
mounting plate 37mm

Drilling pattern

Dimensions

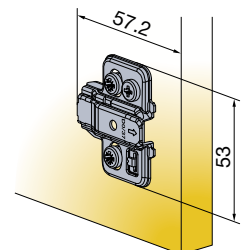
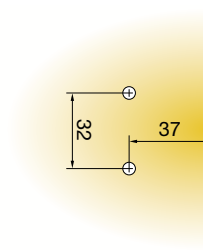

150 Pcs Made of steel

Cam adjustable linear
mounting plate

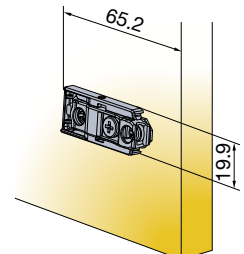
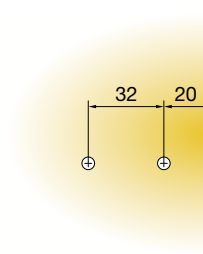

150 Pcs Made of steel and zinc

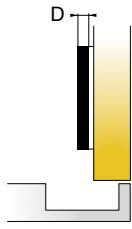

Mounting plate thickness

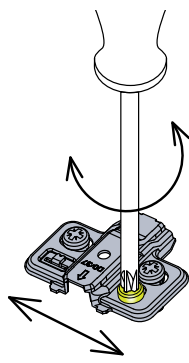

Height adjustment +2/-2mm

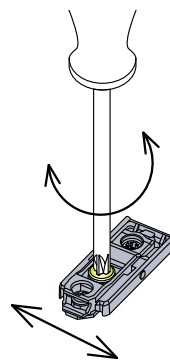

Height adjustment +2/-2mm

Mounting plate type	15		10.5	15	
Mounting plate thickness (D)					
Item number	Item number	Item number	Item number	Item number	
0mm	700-0KC0-054	700-0KB0-054	700-0KF0-054	700-0KA0-054	
1mm	700-0KC1-054	700-0KB1-054	700-0KF1-054	700-0KA1-054	
2mm	700-0KC2-054	700-0KB2-054	700-0KF2-054	700-0KA2-054	
3mm	700-0KC3-054	700-0KB3-054	700-0KF3-054	700-0KA3-054	
4mm	700-0KC4-054	700-0KB4-054	700-0KF4-054	700-0KA4-054	
0mm	700-0LC0-650	700-0LB0-650	700-0LF0-650		
2mm	700-0LC2-650	700-0LB2-650	700-0LF2-650		
3mm	700-0LC3-650	700-0LB3-650	700-0LF3-650		

Legend of mounting plate type symbols



Pre-mounted 15mm euro screws



Machine insertion ready



Pre-mounted 10.5mm expanding dowels



Pre-mounted chipboard screw

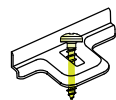
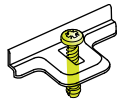
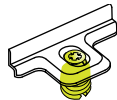
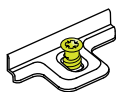

T-type Mounting Plates

3Way snap-on mounting

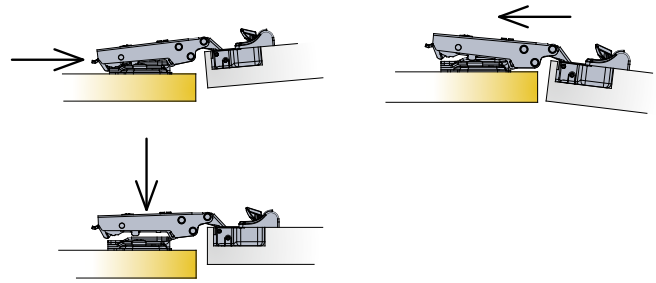

Cruciform mounting plate 37mm

Drilling pattern

Dimensions

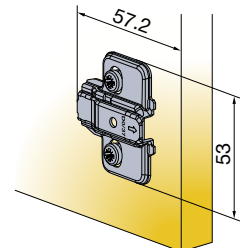
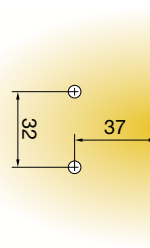

 150 Pcs Made of steel

Cam adjustable
face frame mounting plate

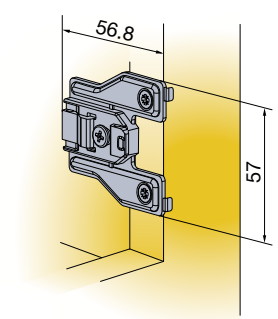
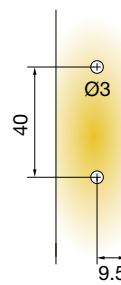

 150 Pcs Made of steel and zinc

Fixing screw for cruciform mounting plate
If not pre-mounted

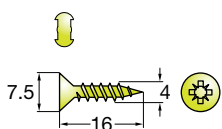

Chipboard screws
820-6328-050

 10000 Pcs

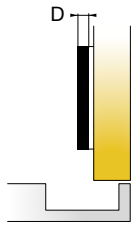

Mounting plate thickness

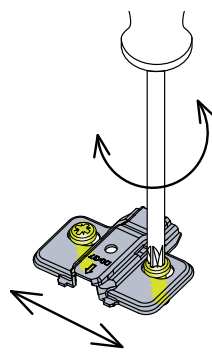



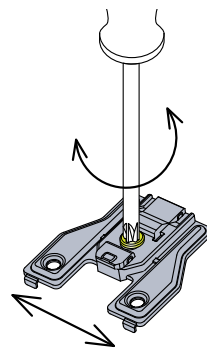







Height adjustment +2/-2mm



Height adjustment +2/-2mm

Mounting plate type		 15		 10.5	 14.5		
Mounting plate thickness (D)							
Item number	Item number	Item number	Item number	Item number	Item number	Item number	Item number
0mm	700-0NA0-054	700-0NC0-054	700-0NB0-054	700-0NF0-054	700-0NE0-054		
1mm	700-0NA1-054	700-0NC1-054	700-0NB1-054	700-0NF1-054	700-0NE1-054		
2mm	700-0NA2-054	700-0NC2-054	700-0NB2-054	700-0NF2-054	700-0NE2-054		
3mm	700-0NA3-054	700-0NC3-054	700-0NB3-054	700-0NF3-054	700-0NE3-054		
4mm	700-0NA4-054	700-0NC4-054	700-0NB4-054	700-0NF4-054	700-0NE4-054		
0mm						700-0KW0-054	
3mm						700-0KW3-054	

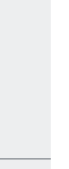
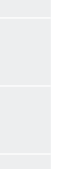
Legend of mounting plate type symbols

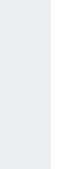
	 15		 10.5	 15	 14.5
Screw-on ready for chipboard screws ← screws	Pre-mounted 15mm euro screws	Machine insertion ready	Pre-mounted 10.5mm expanding dowels	Pre-mounted chipboard screw	Pre-mounted chipboard screw
					

S-type Hinges

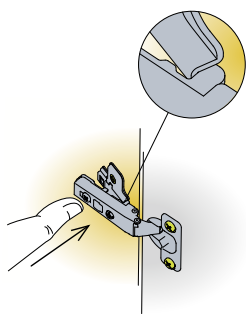

Snap-on mounting system

- Easy and quick assembly and disassembly
- Flexibility for the furniture user
- Tight hinge-to-plate joint improves hinge stability and reduces door sag

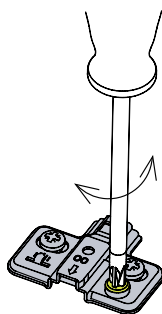

Easily accessible height adjustment with cam

- Intuitive and quick height adjustment
- Consumer friendly

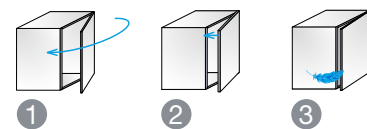

ConfidentClose

- 1 Fast closing
- 2 Late start of deceleration action
- 3 Quiet landing with SoftTouch

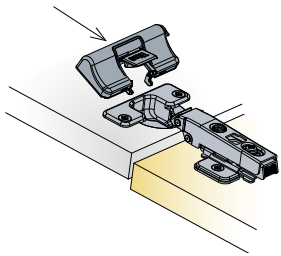
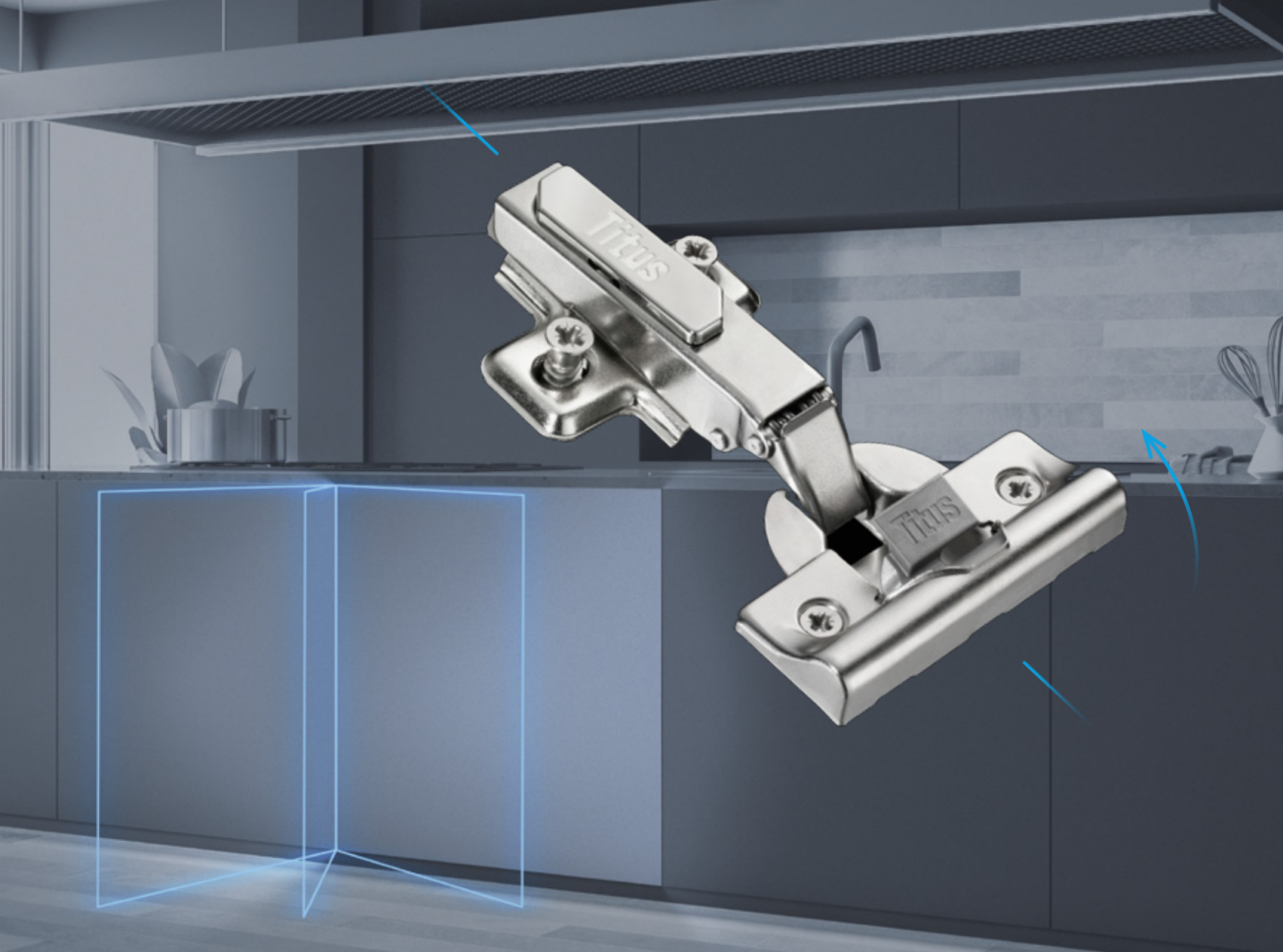

Soft closing options

- Hinge integrated
- Add-on with Glissando ready hinge cup
- Stand-alone

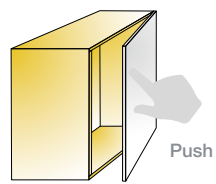

Touch opening

- Guarantees effortless opening
- Elegant cabinet design
- Doors without handles

S-type-i3 110

For wood doors

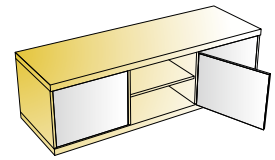
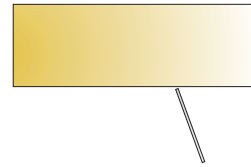
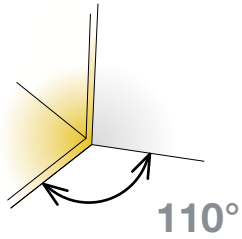

- Opening angle
- Drilling diameter for hinge cup
- Drilling depth
- Hinge on plate mounting system

110°
35mm
min. 11mm
snap-on



Technical details

Cup type	Interaxis 45mm	Interaxis 48mm
	Item number	Item number

Cranking
0mm

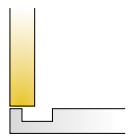

200 Pcs



Made of steel and plastic

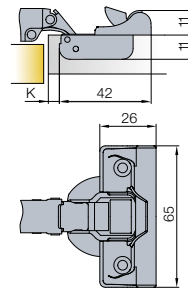

242-0970-054

242-0971-054

Drilling patterns for hinge cups → see page 2.17

Cranking
9mm

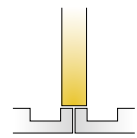

200 Pcs



Made of steel and plastic

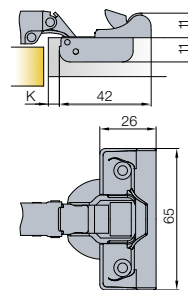

242-0976-054

242-0977-054

Drilling patterns for hinge cups → see page 2.17

Cranking
15mm

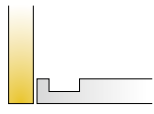

200 Pcs



Made of steel and plastic

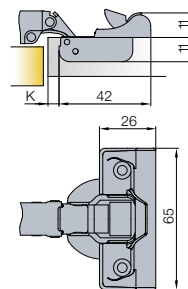

242-0997-054

242-0998-054

Drilling patterns for hinge cups → see page 2.17

Mounting plates



Cam adjustable cruciform mounting plate
→ see page 2.127



Cruciform mounting plate
→ see page 2.129



Face frame adapter
→ see page 2.131

Hinge cup screws If not pre-mounted

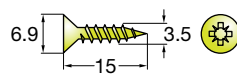

820-6308-050

10000 Pcs

Accessories



Cover caps for hinge arm
→ see page 2.177



Hinge angle restrictor
→ see page 2.175

Legend of hinge cup symbols



Screw-on ready
← screws



Door adjustment

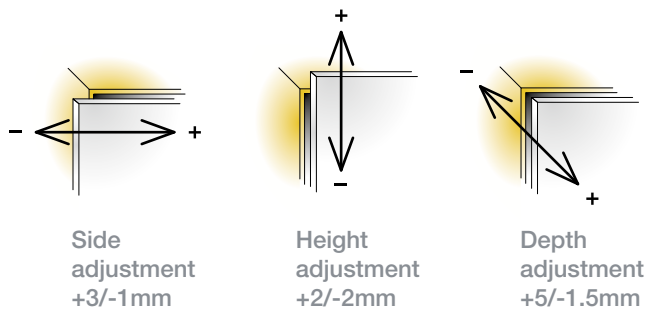

For further explanation → see pages 2.22-2.24

Mounting details

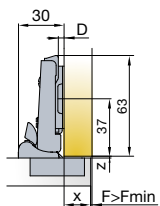
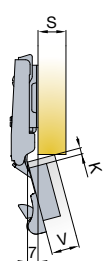

Drawings show application on D=0mm mounting plate

Mounting plate drilling distance

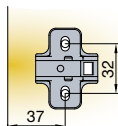

Mounting plate thickness table

For further explanation → see page 2.13

X	13	14	15	16	17	18
3	3	2	1	0		
K	4	3	2	1	0	
5			3	2	1	0

$D=13+K-X$

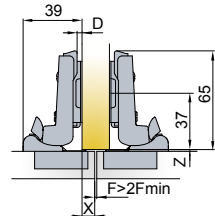
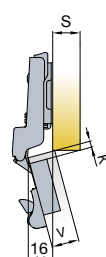

Drawings show application on D=0mm mounting plate

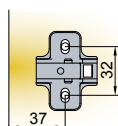

X	4	5	6	7	8	9
3	3	2	1	0		
K	4	3	2	1	0	
5			3	2	1	0

$D=4+K-X$

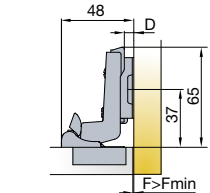
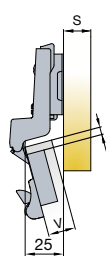

Drawings show application on D=3mm mounting plate

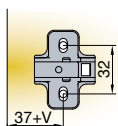

V	16	17	18	19	20	21
3	2	2	2	3	3	3
K	4	3	3	3		
5	3					

$D=-2+K+F$

Touch opening



PushOpen Solutions
→ see pages 2.199-2.204

Door clearance

For further explanation → see page 2.14

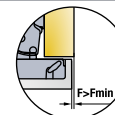

V	16	17	18	19	20	21	22
3	0.3	0.5	0.7	1.0	1.3	1.7	2.5
K	4	0.3	0.5	0.7	0.9	1.2	1.6
5	0.3	0.5	0.7	0.9	1.2	1.5	2.0

Gap $Z_{MIN}=0$

S-type-i3 110/15°

For wood doors

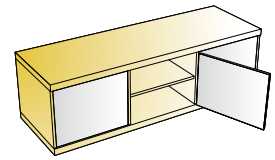
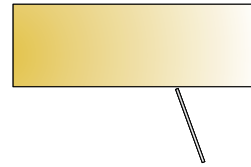
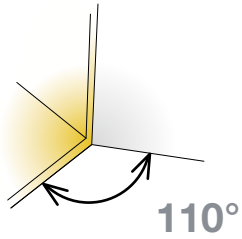

- Opening angle
- Drilling diameter for hinge cup
- Drilling depth
- Hinge on plate mounting system

110°
35mm
min. 11mm
snap-on



Technical details

	Interaxis 45mm	Interaxis 48mm
Cup type		
Item number	242-0W71-650	242-0W72-650

Cranking
9mm

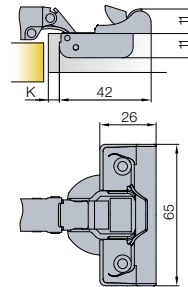
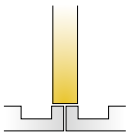

Drilling patterns for hinge cups → see page 2.17

200 Pcs

Made of steel and plastic

Mounting plates



Cam adjustable cruciform mounting plate
→ see page 2.127



Cruciform mounting plate
→ see page 2.129



Face frame adapter
→ see page 2.131

Hinge cup screws
If not pre-mounted

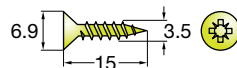

820-6308-050
 10000 Pcs

Accessories



Cover caps for hinge arm
→ see page 2.177



Hinge angle restrictor
→ see page 2.175

Legend of hinge cup symbols

Screw-on ready
← screws

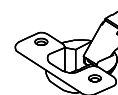

Door adjustment

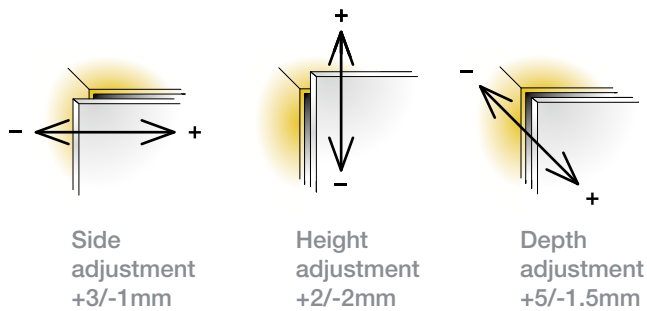

For further explanation → see pages 2.22-2.24

Mounting details

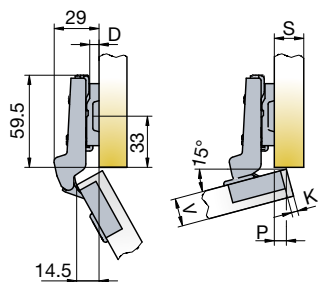

Drawings show application on D=0 and K=4mm mounting plate

Mounting plate drilling distance

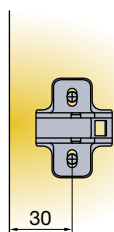

Mounting plate thickness table

For further explanation → see page 2.13

X	4	5	6	7	8	9
3	3	2	1	0		
K 4		3	2	1	0	
5			3	2	1	0

$D=4+K-X$

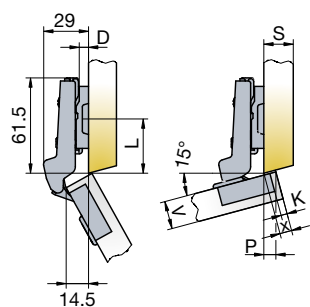

Drawings show application on D=0 and K=4mm mounting plate

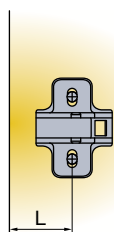

L=37 for thickness D=0
 L=36 for thickness D=1
 L=36 for thickness D=2
 L=35 for thickness D=3
 L=33 for thickness D=9

X, P	1	2	3	7	8	9	10	11	12
3	9			3	2	1	0		
K 4		9			3	2	1	0	
5			9			3	2	1	0

Touch opening



PushOpen Solutions
 → see pages 2.199-2.204

Door clearance

For further explanation → see page 2.14



V	16	17	18	19	20	21	22
3	0.3	0.5	0.7	1.0	1.3	1.7	2.5
K 4	0.3	0.5	0.7	0.9	1.2	1.6	2.1
5	0.3	0.5	0.7	0.9	1.2	1.5	2.0

Gap $Z_{MIN}=0$

S-type-i3 110/24°

For wood doors

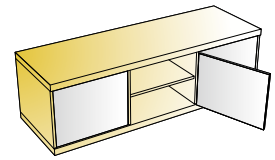
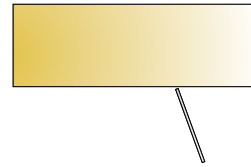
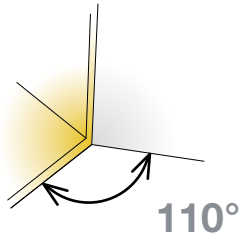

- Opening angle
- Drilling diameter for hinge cup
- Drilling depth
- Hinge on plate mounting system

110°
35mm
min. 11mm
snap-on



Technical details

	Interaxis 45mm	Interaxis 48mm
Cup type		
Item number	242-0W48-650	

Cranking
9mm

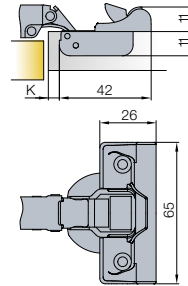
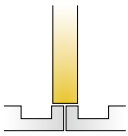

Drilling patterns for hinge cups → see page 2.17

200 Pcs

Made of steel and plastic

Mounting plates



Cam adjustable cruciform mounting plate
→ see page 2.127



Cruciform mounting plate
→ see page 2.129



Face frame adapter
→ see page 2.131

Hinge cup screws
If not pre-mounted

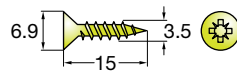

820-6308-050

10000 Pcs

Accessories



Cover caps for hinge arm
→ see page 2.177



Hinge angle restrictor
→ see page 2.175

Legend of hinge cup symbols

Screw-on ready
← screws



Door adjustment

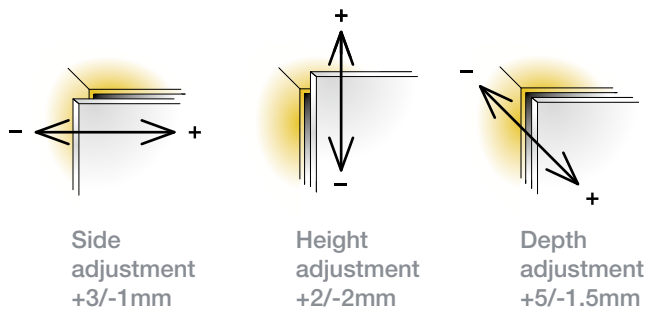

For further explanation → see pages 2.22-2.24

Mounting details

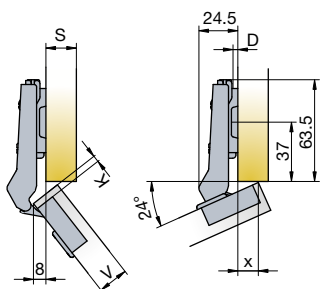

Mounting plate drilling distance

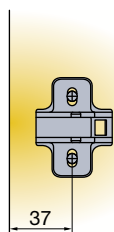

Mounting plate thickness table

For further explanation → see page 2.13

X	3	4	5	9	10	11	12	13	14
3	9			3	2	1	0		
K	4	9			3	2	1	0	
5			9			3	2	1	0

Drawings show application on D=0mm mounting plate

Touch opening



PushOpen Solutions
→ see pages 2.199-2.204

Door clearance

For further explanation → see page 2.14



V	16	17	18	19	20	21	22	
3	0.3	0.5	0.7	1.0	1.3	1.7	2.5	
K	4	0.3	0.5	0.7	0.9	1.2	1.6	2.1
5	0.3	0.5	0.7	0.9	1.2	1.5	2.0	F _{MIN}

Gap Z_{MIN}=0

S-type-i3 110/30°

30° angled application for wood doors

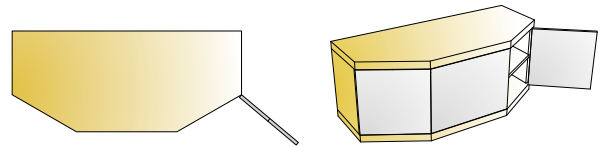
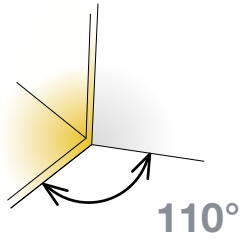

- Opening angle
- Drilling diameter for hinge cup
- Drilling depth
- Hinge on plate mounting system

110°
35mm
min. 11mm
snap-on



Technical details

	Interaxis 45mm	Interaxis 48mm
Cup type		
Item number	242-0885-650	242-0886-650

Cranking
9mm

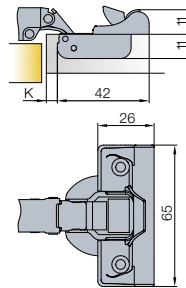
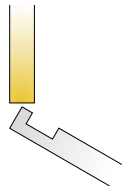

Drilling patterns for hinge cups → see page 2.17

100 Pcs

Cup made of steel and plastic, arm made of zinc

Mounting plates



Cam adjustable cruciform mounting plate
→ see page 2.127



Cruciform mounting plate
→ see page 2.129



Face frame adapter
→ see page 2.131

Hinge cup screws

If not pre-mounted

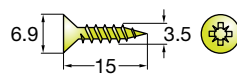

820-6308-050

10000 Pcs

Accessories



Cover caps for hinge arm
→ see page 2.177



Hinge angle restrictor
→ see page 2.175

Legend of hinge cup symbols

Screw-on ready
← screws



Door adjustment

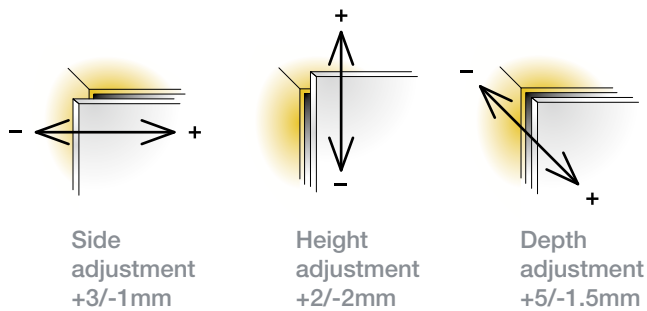

For further explanation → see pages 2.22-2.24

Mounting details

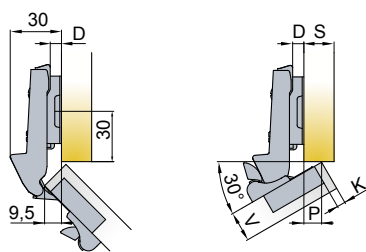

Mounting plate drilling distance

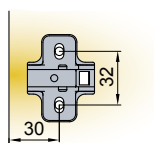

Mounting plate thickness table

For further explanation → see page 2.13

P	2.5	3.5	4.5	8.5	9.5	10.5	11.5	12.5	13.5
3	9			3	2	1	0		
K 4		9			3	2	1	0	
5			9			3	2	1	0 D

Drawings show application on D=3mm mounting plate

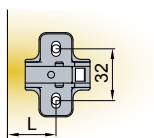
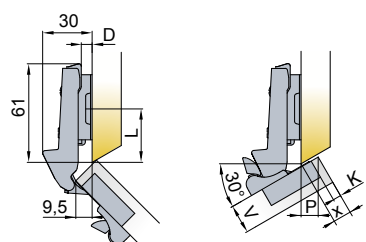

X	2	3	4	9	10	11	12	13	14	15
3	9			3	2			0		
K 4		9			3	2			0	
5			9			3	2			0 D

L=37 for thickness D=0
 L=36 for thickness D=1
 L=35 for thickness D=2
 L=34 for thickness D=3
 L=31 for thickness D=9

Drawings show application on D=3mm mounting plate

Touch opening



PushOpen Solutions
 → see pages 2.199-2.204

Door clearance

For further explanation → see page 2.14

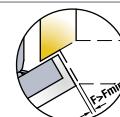

V	16	17	18	19	20	21	22
3	0.3	0.5	0.7	1.0	1.3	1.7	2.5
K 4	0.3	0.5	0.7	0.9	1.2	1.6	2.1
5	0.3	0.5	0.7	0.9	1.2	1.5	2.0 F _{MIN}

Gap Z_{MIN}=0

S-type-i3 110/45°

45° angled application for wood doors

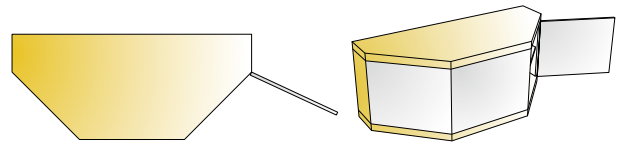
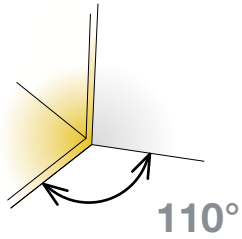

- Opening angle
- Drilling diameter for hinge cup
- Drilling depth
- Hinge on plate mounting system

110°
35mm
min. 11mm
snap-on



Technical details

	Interaxis 45mm	Interaxis 48mm
Cup type		
Item number	242-0P81-650	242-0824-650

Cranking
9mm

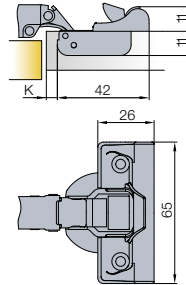
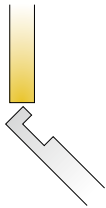

Drilling patterns for hinge cups → see page 2.17

100 Pcs

Cup made of steel and plastic, arm made of zinc

Mounting plates



Cam adjustable cruciform mounting plate
→ see page 2.127



Cruciform mounting plate
→ see page 2.129



Face frame adapter
→ see page 2.131

Hinge cup screws If not pre-mounted

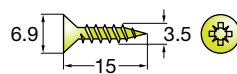

820-6308-050

10000 Pcs

Accessories



Cover caps for hinge arm
→ see page 2.177



Hinge angle restrictor
→ see page 2.175

Legend of hinge cup symbols

Screw-on ready
← screws



Door adjustment

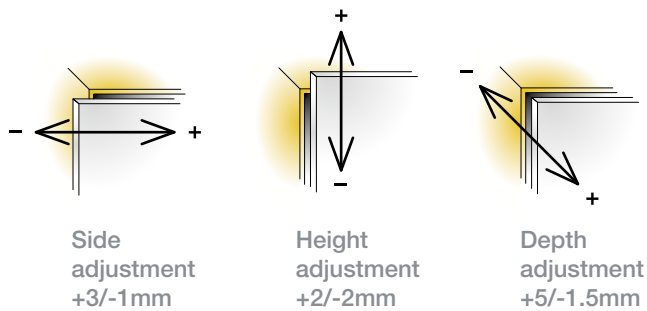

For further explanation → see pages 2.22-2.24

Mounting details

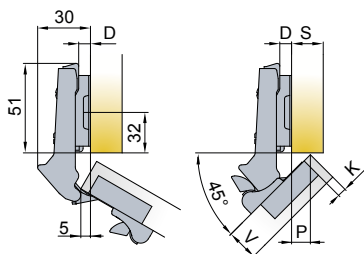

Mounting plate drilling distance

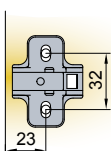

Mounting plate thickness table

For further explanation → see page 2.13

P	9	9.5	10	10.5	11	11.5	12	12.5	13.5
3	3		2		1		0		
K 4		3		2		1		0	
5				3		2		1	0 D

Drawing show application on D=3mm mounting plate

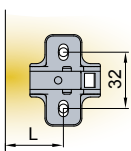
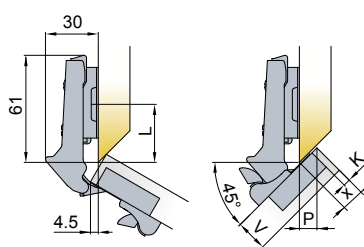

X 11.5 12.5 13 13.5 14 14.5 15 15.5 16 16.5 17 18

3	3		2		1		0					
K 4		3		2		1		0				
5				3		2		1	0	D		

Drawings show application on D=3mm mounting plate

L=36 for thickness D=0
L=35 for thickness D=1
L=34 for thickness D=2
L=33 for thickness D=3

Touch opening



PushOpen Solutions
→ see pages 2.199-2.204

Door clearance

For further explanation → see page 2.14

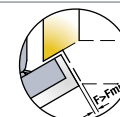

V	16	17	18	19	20	21	22
3	0.3	0.5	0.7	1.0	1.3	1.7	2.5
K 4	0.3	0.5	0.7	0.9	1.2	1.6	2.1
5	0.3	0.5	0.7	0.9	1.2	1.5	2.0 F _{MIN}

Gap Z_{MIN}=0

S-type-i3 110/45°

45° angled application for wood doors

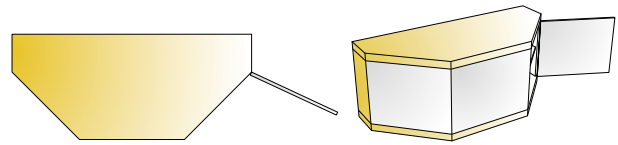
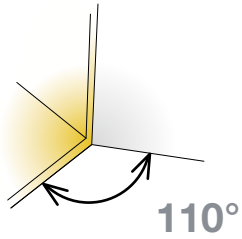

- Opening angle
 - Drilling diameter for hinge cup
 - Drilling depth
 - Hinge on plate mounting system
- 110°
35mm
min. 11mm
snap-on



Technical details

	Interaxis 45mm	Interaxis 48mm
Cup type		
Item number		

Cranking
18mm

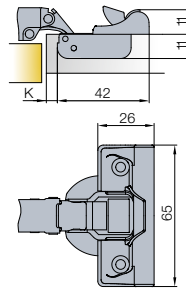
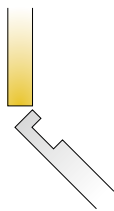

	242-0G76-650	242-0H17-650
--	--------------	--------------

Drilling patterns for hinge cups → see page 2.17

100 Pcs

Cup made of steel and plastic, arm made of zinc

Mounting plates



Cam adjustable cruciform mounting plate
→ see page 2.127



Cruciform mounting plate
→ see page 2.129



Face frame adapter
→ see page 2.131

Hinge cup screws

If not pre-mounted

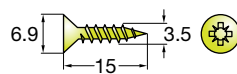

820-6308-050

10000 Pcs

Accessories



Cover caps for hinge arm
→ see page 2.177



Hinge angle restrictor
→ see page 2.175

Legend of hinge cup symbols

Screw-on ready
← screws



Door adjustment

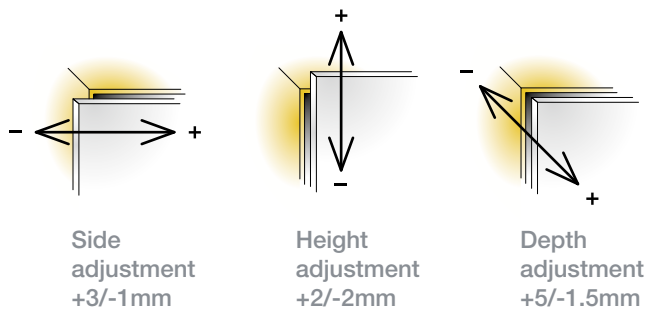

For further explanation → see pages 2.22-2.24

Mounting details

Mounting plate drilling distance

Mounting plate thickness table
For further explanation → see page 2.13

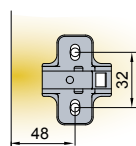
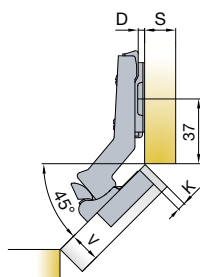
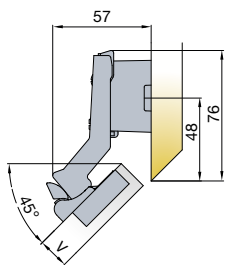

Drawing shows application on D=18mm mounting plate

Drawing shows application on D=0mm mounting plate

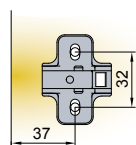
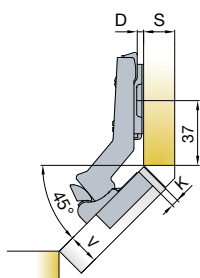
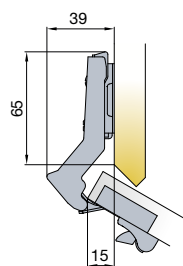

K	3	4	5
D	0	1	2

Drawings show application on D=0mm mounting plate

Touch opening



PushOpen Solutions
→ see pages 2.199-2.204

Door clearance

For further explanation → see page 2.14

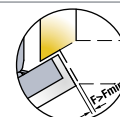

V	16	17	18	19	20	21	22
3	0.3	0.5	0.7	1.0	1.3	1.7	2.5
K 4	0.3	0.5	0.7	0.9	1.2	1.6	2.1
5	0.3	0.5	0.7	0.9	1.2	1.5	2.0

Gap Z_{MIN}=0

S-type-i3 110/90°

For wood door cabinets with blind panels

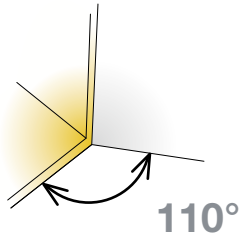
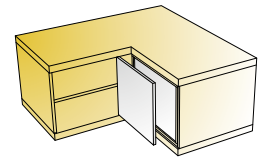

- Opening angle
- Drilling diameter for hinge cup
- Drilling depth
- Hinge on plate mounting system

110°
35mm
min. 11mm
snap-on



Technical details

	Interaxis 45mm	Interaxis 48mm
Cup type		
Item number	242-0Y45-650	242-0Y46-650

Cranking
18mm

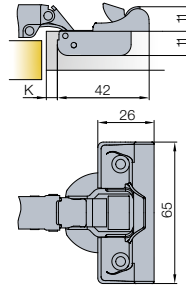
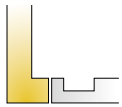

Drilling patterns for hinge cups → see page 2.17



100 Pcs

Cup made of steel and plastic, arm made of zinc

Mounting plates



Cam adjustable cruciform mounting plate
→ see page 2.127



Cruciform mounting plate
→ see page 2.129



Face frame adapter
→ see page 2.131

Hinge cup screws

If not pre-mounted

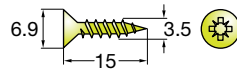

820-6308-050

10000 Pcs

Accessories



Cover caps for hinge arm
→ see page 2.177



Hinge angle restrictor
→ see page 2.175

Legend of hinge cup symbols

Screw-on ready
← screws



Door adjustment

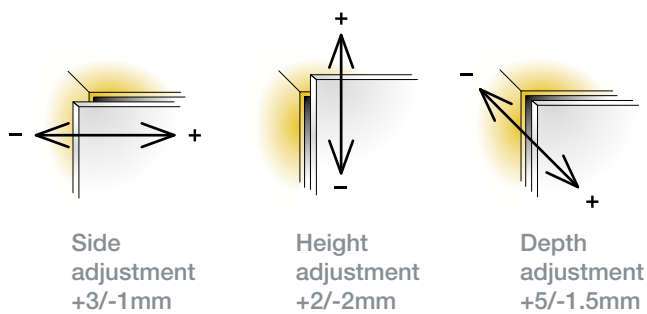

For further explanation → see pages 2.22-2.24

Mounting details

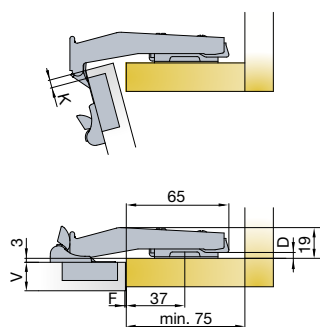

Drawings show application on D=0mm mounting plate

Mounting plate drilling distance

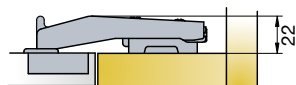
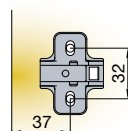

Drawing shows application on D=3mm mounting plate

Touch opening



PushOpen Solutions
→ see pages 2.199-2.204

Door clearance

For further explanation → see page 2.14

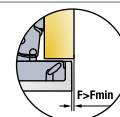

V	16	17	18	19	20	21	22	
3	0.3	0.5	0.7	1.0	1.3	1.7	2.5	
K	4	0.3	0.5	0.7	0.9	1.2	1.6	2.1
5	0.3	0.5	0.7	0.9	1.2	1.5	2.0	F _{MIN}

Gap Z_{MIN}=0

S-type 110

For wood doors

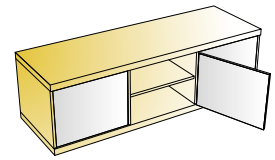
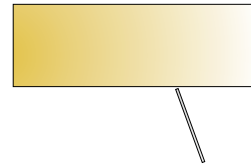
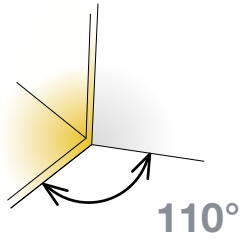

- Opening angle
- Drilling diameter for hinge cup
- Drilling depth
- Hinge on plate mounting system

110°
35mm
11.5mm
snap-on



	Interaxis 45mm	Interaxis 48mm
Cup type	Item number	Item number

Cranking
0mm

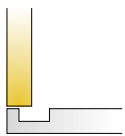

200 Pcs

Made of steel

	248-0535-050	248-0532-050
	248-0171-050	248-0172-050
	248-0186-050	248-0188-050

Drilling patterns for hinge cups → see page 2.17

Cranking
9mm

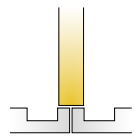

200 Pcs

Made of steel

	248-0536-050	248-0533-050
	248-0279-050	248-0327-050
	248-0482-050	248-0545-050

Drilling patterns for hinge cups → see page 2.17

Cranking
15mm

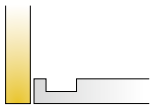

200 Pcs

Made of steel

	248-0537-050	248-0534-050
	248-0280-050	248-0328-050
	248-0487-050	248-0547-050

Drilling patterns for hinge cups → see page 2.17

Mounting plates



Cam adjustable cruciform mounting plate
→ see page 2.127



Cruciform mounting plate
→ see page 2.129



Face frame adapter
→ see page 2.131

Hinge cup screws

If not pre-mounted

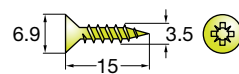

820-6308-050

10000 Pcs

Accessories



Cover caps for hinge arm
→ see page 2.177



Hinge angle restrictor
→ see page 2.175

Legend of hinge cup symbols

Screw-on ready
← screws

Machine insertion ready

EasyFix system

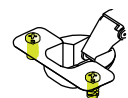
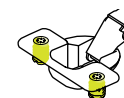

Door adjustment

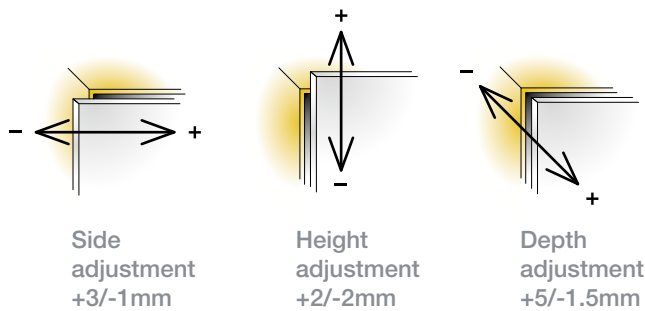

For further explanation → see pages 2.22-2.24

Mounting details

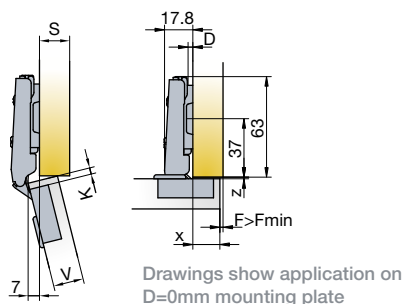

Mounting plate drilling distance

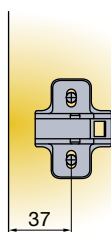

Mounting plate thickness table

For further explanation → see page 2.13

X	13	14	15	16	17	18
3	3	2	1	0		
K	4	3	2	1	0	
5			3	2	1	0

$D=13+K-X$

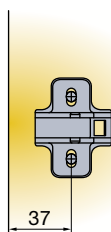
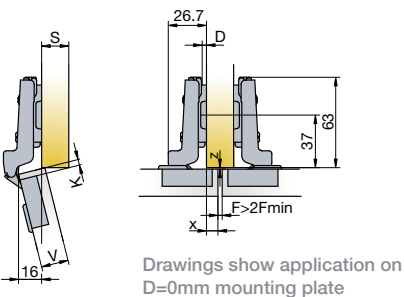

X	4	5	6	7	8	9
3	3	2	1	0		
K	4	3	2	1	0	
5			3	2	1	0

$D=4+K-X$

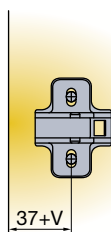
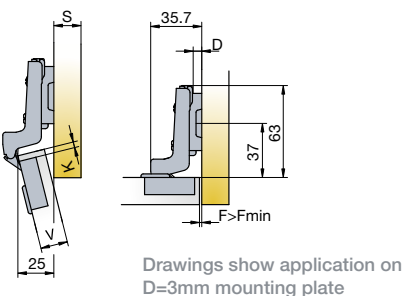

V	16	17	18	19	20	21
3	2	2	2	3	3	3
K	4	3	3	3		
5	3					

$D=-2+K-F$

Soft closing systems



Touch opening

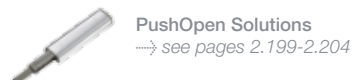

Door clearance

For further explanation → see page 2.14

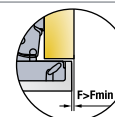

V	16	17	18	19	20	21	22
3	0.3	0.5	0.7	1.0	1.3	1.7	2.5
K	4	0.3	0.5	0.7	0.9	1.2	1.6
5	0.3	0.5	0.7	0.9	1.2	1.5	2.0

Gap Z_{MIN}=0

S-type 110/-15°

-15° angled application for wood doors

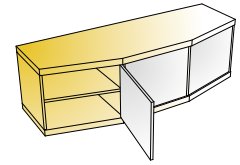
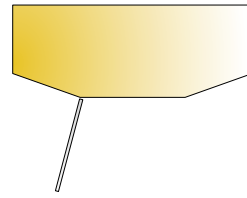
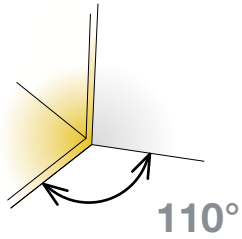

- Opening angle
- Drilling diameter for hinge cup
- Drilling depth
- Hinge on plate mounting system

110°
35mm
11.5mm
snap-on



	Interaxis 45mm	Interaxis 48mm
Cup type	Item number	Item number
	248-0V14-050	248-0V39-050
	248-0V41-050	248-0V42-050

Cranking
0mm

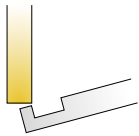

Drilling patterns for hinge cups → see page 2.17

100 Pcs

Cup made of steel, arm made of zinc

Mounting plates



Cam adjustable cruciform mounting plate
→ see page 2.127



Cruciform mounting plate
→ see page 2.129



Face frame adapter
→ see page 2.131

Hinge cup screws

If not pre-mounted

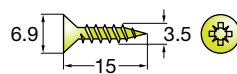

820-6308-050

10000 Pcs

Accessories



Cover caps for hinge arm
→ see page 2.177



Hinge angle restrictor
→ see page 2.175

Legend of hinge cup symbols

Screw-on ready
← screws

Machine insertion ready

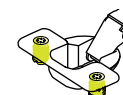

Door adjustment

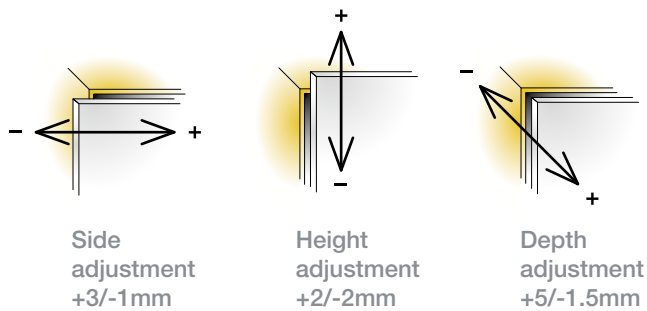

For further explanation → see pages 2.22-2.24

Mounting details

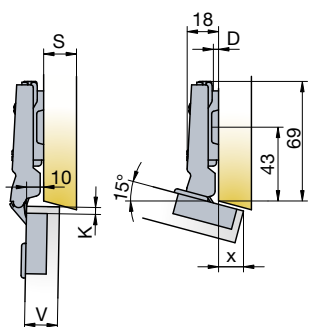

Mounting plate drilling distance

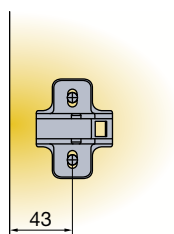

Mounting plate thickness table

For further explanation → see page 2.13

X	4	5	6	10	11	12	13	14	15
3	9			3	2	1	0		
K 4		9			3	2	1	0	
5			9			3	2	1	0 D

Drawings show application on D=0mm mounting plate

Touch opening



PushOpen Solutions
→ see pages 2.199-2.204

Door clearance

For further explanation → see page 2.14

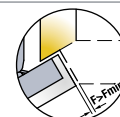

V	16	17	18	19	20	21	22
3	0.3	0.5	0.7	1.0	1.3	1.7	2.5
K 4	0.3	0.5	0.7	0.9	1.2	1.6	2.1
5	0.3	0.5	0.7	0.9	1.2	1.5	2.0 F _{MIN}

Gap Z_{MIN}=0

S-type 110/15°

15° angled application for wood doors

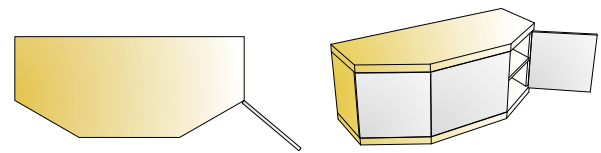
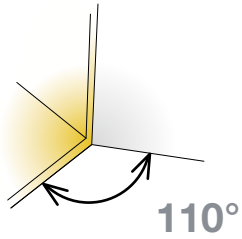

- Opening angle 110°
- Drilling diameter for hinge cup 35mm
- Drilling depth 11.5mm
- Hinge on plate mounting system snap-on



Cup type	Interaxis 45mm	Interaxis 48mm
	Item number	Item number
	248-0080-050	248-0V62-050

Cranking
9mm

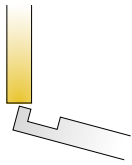

Drilling patterns for hinge cups → see page 2.17

100 Pcs

Cup made of steel, arm made of zinc

Mounting plates



Cam adjustable cruciform mounting plate
→ see page 2.127



Cruciform mounting plate
→ see page 2.129



Face frame adapter
→ see page 2.131

Hinge cup screws

If not pre-mounted

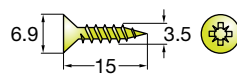

820-6308-050

10000 Pcs

Accessories



Cover caps for hinge arm
→ see page 2.177



Hinge angle restrictor
→ see page 2.175

Legend of hinge cup symbols

Screw-on ready
← screws



Door adjustment

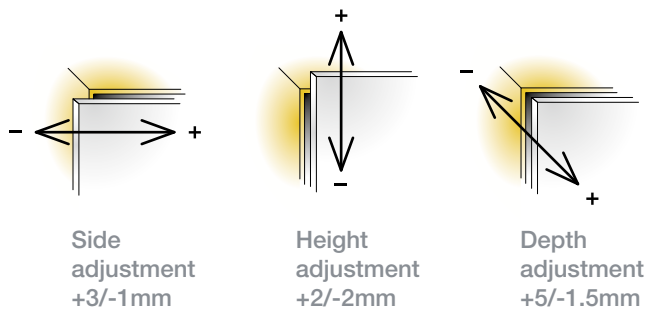

For further explanation → see pages 2.22-2.24

Mounting details

Mounting plate drilling distance

Mounting plate thickness table

For further explanation → see page 2.13

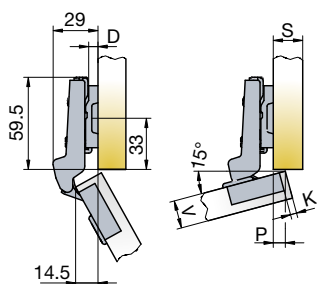

Drawings show application on D=0 and K=4mm mounting plate

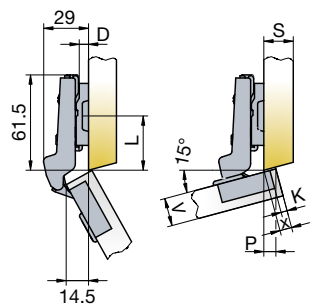
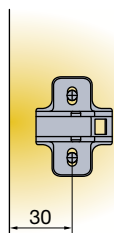

Drawings show application on D=0 and K=4mm mounting plate

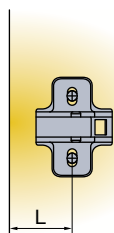

L=37 for thickness D=0
 L=36 for thickness D=1
 L=36 for thickness D=2
 L=35 for thickness D=3
 L=33 for thickness D=9

X, P 1 2 3 7 8 9 10 11 12

3	9		3	2	1	0			
K 4		9		3	2	1	0		
5			9		3	2	1	0	D

Soft closing systems



Glissando TL3
 → see page 2.189

Touch opening



PushOpen Solutions
 → see pages 2.199-2.204

Door clearance

For further explanation → see page 2.14

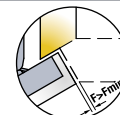

V 16 17 18 19 20 21 22

3	0.3	0.5	0.7	1.0	1.3	1.7	2.5
K 4	0.3	0.5	0.7	0.9	1.2	1.6	2.1
5	0.3	0.5	0.7	0.9	1.2	1.5	2.0 F _{MIN}

Gap Z_{MIN}=0

S-type 110/24°

24° angled application for wood doors

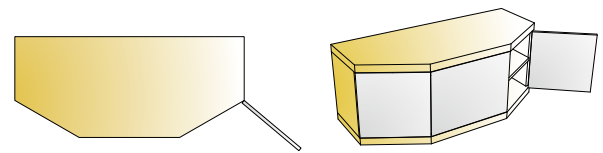
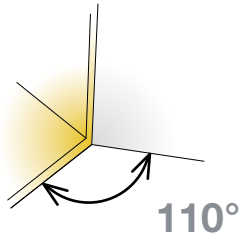

- Opening angle 110°
- Drilling diameter for hinge cup 35mm
- Drilling depth 11.5mm
- Hinge on plate mounting system snap-on



	Interaxis 45mm	Interaxis 48mm
Cup type	Item number	Item number
	248-0V18-050	248-0V45-050
	248-0V47-050	248-0V48-050

Cranking
9mm

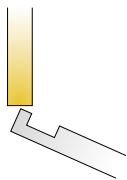

Drilling patterns for hinge cups → see page 2.17

100 Pcs

Cup made of steel, arm made of zinc

Mounting plates



Cam adjustable cruciform mounting plate
→ see page 2.127



Cruciform mounting plate
→ see page 2.129



Face frame adapter
→ see page 2.131

Hinge cup screws If not pre-mounted

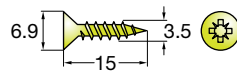

820-6308-050

10000 Pcs

Accessories



Cover caps for hinge arm
→ see page 2.177



Hinge angle restrictor
→ see page 2.175

Legend of hinge cup symbols

Screw-on ready
← screws

Machine insertion ready

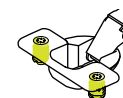

Door adjustment

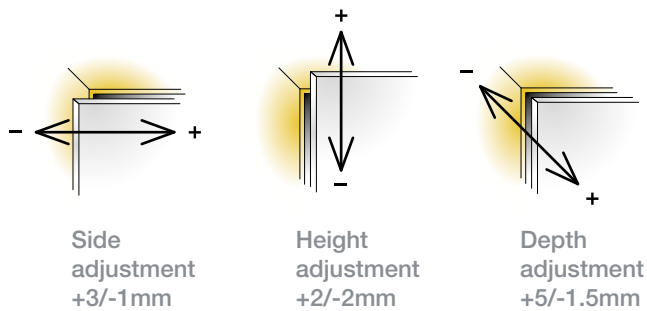

For further explanation → see pages 2.22-2.24

Mounting details

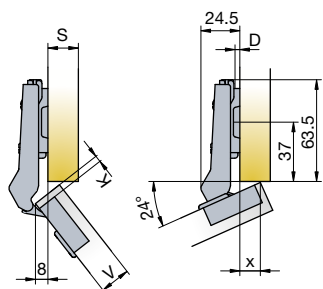

Mounting plate drilling distance

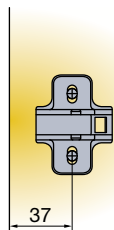

Mounting plate thickness table

For further explanation → see page 2.13

X	3	4	5	9	10	11	12	13	14
3	9			3	2	1	0		
K	4	9			3	2	1	0	
5			9			3	2	1	0

D

Drawings show application on D=0mm mounting plate

Soft closing systems



Glissando TL3
→ see page 2.189

Touch opening



PushOpen Solutions
→ see pages 2.199-2.204

Door clearance

For further explanation → see page 2.14

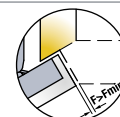

V	16	17	18	19	20	21	22
3	0.3	0.5	0.7	1.0	1.3	1.7	2.5
K	4	0.3	0.5	0.7	0.9	1.2	1.6
5	0.3	0.5	0.7	0.9	1.2	1.5	2.0

F_{MIN}

Gap Z_{MIN}=0

S-type 110/30°

30° angled application for wood doors

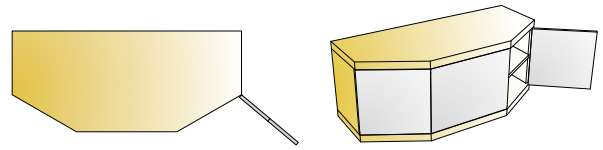
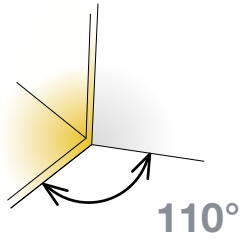

- Opening angle 110°
- Drilling diameter for hinge cup 35mm
- Drilling depth 11.5mm
- Hinge on plate mounting system snap-on



	Interaxis 45mm	Interaxis 48mm
Cup type	Item number	Item number
	248-0675-050	248-0665-050
	248-0N12-050	248-0N13-050

Cranking
9mm

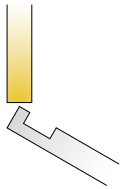

Drilling patterns for hinge cups → see page 2.17

200 Pcs

Cup made of steel, arm made of zinc

Mounting plates



Cam adjustable cruciform mounting plate
→ see page 2.127



Cruciform mounting plate
→ see page 2.129



Face frame adapter
→ see page 2.131

Hinge cup screws

If not pre-mounted

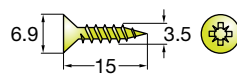

820-6308-050

10000 Pcs

Accessories



Cover caps for hinge arm
→ see page 2.177



Hinge angle restrictor
→ see page 2.175

Legend of hinge cup symbols

Screw-on ready
← screws

Machine insertion ready

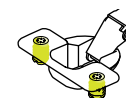
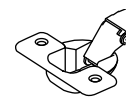

Door adjustment

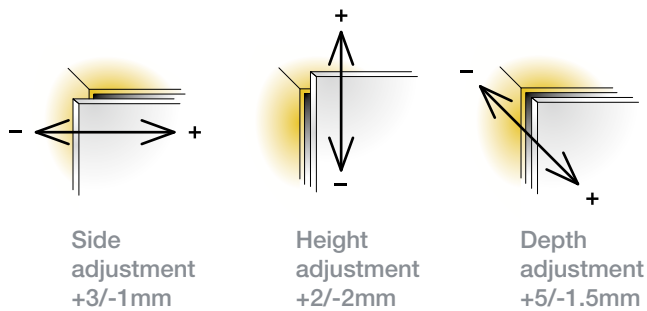

For further explanation → see pages 2.22-2.24

Mounting details

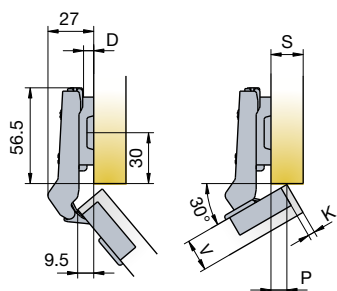

Drawings show application on D=3mm mounting plate

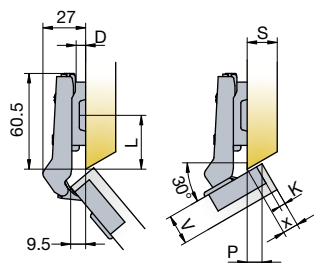

Drawings show application on D=3mm mounting plate

Mounting plate drilling distance

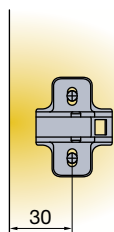

L=37 for thickness D=0
 L=36 for thickness D=1
 L=35 for thickness D=2
 L=34 for thickness D=3
 L=31 for thickness D=9

Mounting plate thickness table

For further explanation → see page 2.13

P	2.5	3.5	4.5	8.5	9.5	10.5	11.5	12.5	13.5
3	9			3	2	1	0		
K	4	9			3	2	1	0	
5			9			3	2	1	0

X	2	3	4	9	10	11	12	13	14	15
3	9			3	2			0		
K	4	9			3	2			0	
5			9			3	2			0

Soft closing systems



Glissando TL3
 → see page 2.189

Touch opening



PushOpen Solutions
 → see pages 2.199-2.204

Door clearance

For further explanation → see page 2.14

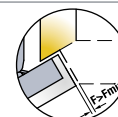

V	16	17	18	19	20	21	22
3	0.3	0.5	0.7	1.0	1.3	1.7	2.5
K	4	0.3	0.5	0.7	0.9	1.2	1.6
5	0.3	0.5	0.7	0.9	1.2	1.5	2.0

Gap Z_{MIN}=0

S-type 110/45°

45° angled application for wood doors

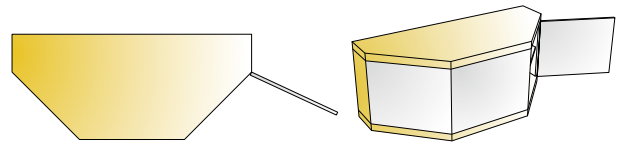
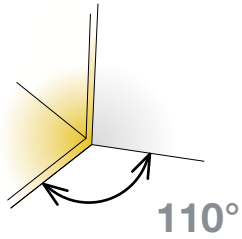

- Opening angle 110°
- Drilling diameter for hinge cup 35mm
- Drilling depth 11.5mm
- Hinge on plate mounting system snap-on



	Interaxis 45mm	Interaxis 48mm
Cup type	Item number	Item number
	248-0433-050	248-0431-050
	248-0N16-050	248-0N17-050

Cranking
9mm

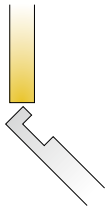

Drilling patterns for hinge cups → see page 2.17

200 Pcs

Cup made of steel, arm made of zinc

Mounting plates



Cam adjustable cruciform mounting plate
→ see page 2.127



Cruciform mounting plate
→ see page 2.129



Face frame adapter
→ see page 2.131

Hinge cup screws If not pre-mounted

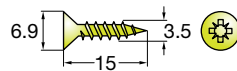

820-6308-050

10000 Pcs

Accessories



Cover caps for hinge arm
→ see page 2.177



Hinge angle restrictor
→ see page 2.175

Legend of hinge cup symbols

Screw-on ready
← screws

Machine insertion ready

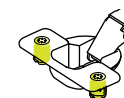

Door adjustment

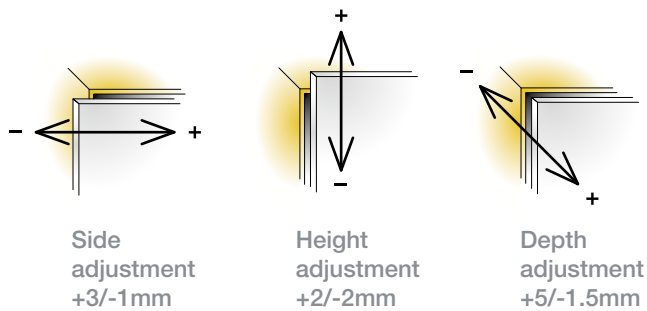

For further explanation → see pages 2.22-2.24

Mounting details

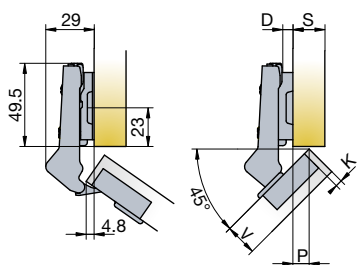

Drawings show application on D=3mm mounting plate

Mounting plate drilling distance

Mounting plate thickness table
For further explanation → see page 2.13

P	9	9.5	10	10.5	11	11.5	12	12.5	13.5
3	3		2		1		0		
K 4		3		2		1		0	
5				3		2		1	0 D

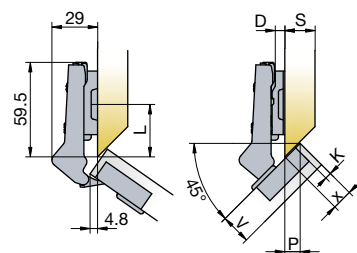

Drawings show application on D=3mm mounting plate

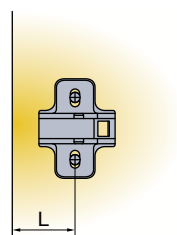

L=36 for thickness D=0
L=35 for thickness D=1
L=34 for thickness D=2
L=33 for thickness D=3

X 11.5 12.5 13 13.5 14 14.5 15 15.5 16 16.5 17 18

3	3		2		1		0					
K 4		3		2		1		0				
5				3		2		1		0	D	

Soft closing systems



Glissando TL3
→ see page 2.189

Touch opening



PushOpen Solutions
→ see pages 2.199-2.204

Door clearance

For further explanation → see page 2.14

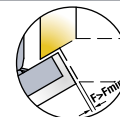

V	16	17	18	19	20	21	22
3	0.3	0.5	0.7	1.0	1.3	1.7	2.5
K 4	0.3	0.5	0.7	0.9	1.2	1.6	2.1
5	0.3	0.5	0.7	0.9	1.2	1.5	2.0 F _{MIN}

Gap Z_{MIN}=0

S-type 110/45°

45° angled application for wood doors

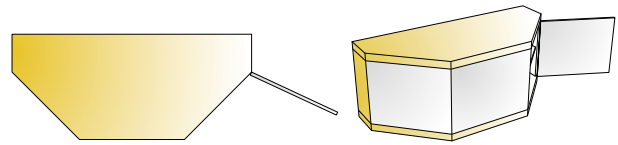
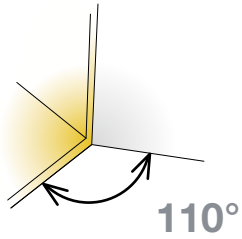

- Opening angle 110°
- Drilling diameter for hinge cup 35mm
- Drilling depth 11.5mm
- Hinge on plate mounting system snap-on



	Interaxis 45mm	Interaxis 48mm
Cup type	Item number	Item number
	248-0285-050	248-0283-050
	248-0N20-050	248-0N21-050

Cranking
18mm

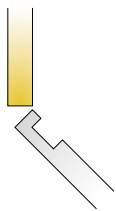

Drilling patterns for hinge cups → see page 2.17

100 Pcs

Cup made of steel, arm made of zinc

Mounting plates



Cam adjustable cruciform mounting plate
→ see page 2.127



Cruciform mounting plate
→ see page 2.129



Face frame adapter
→ see page 2.131

Hinge cup screws

If not pre-mounted

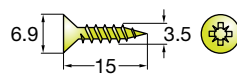

820-6308-050

10000 Pcs

Accessories



Cover caps for hinge arm
→ see page 2.177



Hinge angle restrictor
→ see page 2.175

Legend of hinge cup symbols

Screw-on ready
← screws

Machine insertion ready

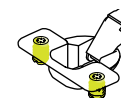

Door adjustment

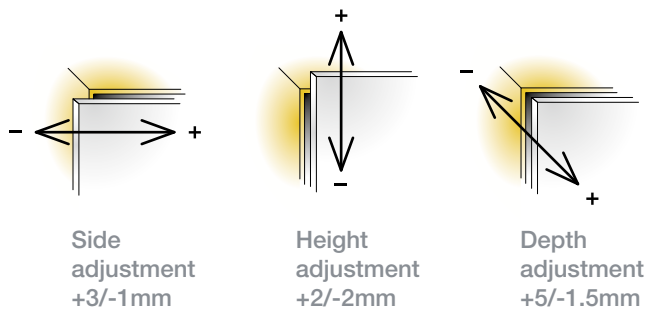

For further explanation → see pages 2.22-2.24

Mounting details

Mounting plate drilling distance

Mounting plate thickness table
For further explanation → see page 2.13

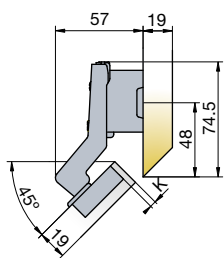

Drawing shows application on D=18mm mounting plate

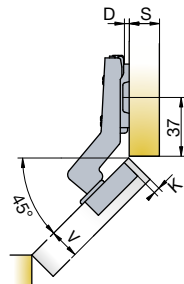

Drawing shows application on D=0mm mounting plate

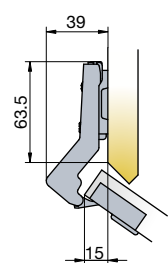
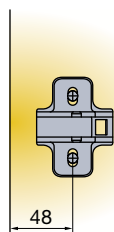

Drawings show application on D=0mm mounting plate

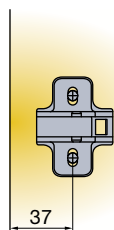
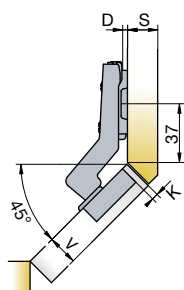

K	3	4	5
D	0	1	2

Soft closing systems



Glissando TL3
→ see page 2.189

Touch opening



PushOpen Solutions
→ see pages 2.199-2.204

Door clearance

For further explanation → see page 2.14

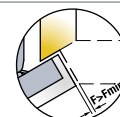

V	16	17	18	19	20	21	22	
3	0.3	0.5	0.7	1.0	1.3	1.7	2.5	
K	4	0.3	0.5	0.7	0.9	1.2	1.6	2.1
5	0.3	0.5	0.7	0.9	1.2	1.5	2.0	F _{MIN}

Gap Z_{MIN}=0

S-type 110/90°

For wood door cabinets with blind panels

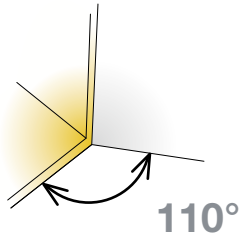
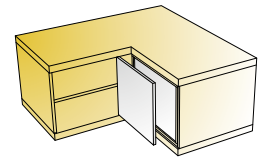

- Opening angle 110°
- Drilling diameter for hinge cup 35mm
- Drilling depth 11.5mm
- Hinge on plate mounting system snap-on



Cup type	Interaxis 45mm	Interaxis 48mm
Item number	Item number	Item number
	248-0745-050	248-0742-050
	248-0N24-050	248-0N25-050
	248-0L61-050	248-0N62-050

Cranking
18mm

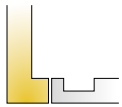

Drilling patterns for hinge cups → see page 2.17

100 Pcs

Cup made of steel, arm made of zinc

Mounting plates



Cam adjustable cruciform mounting plate
→ see page 2.127



Cruciform mounting plate
→ see page 2.129



Face frame adapter
→ see page 2.131

Hinge cup screws If not pre-mounted

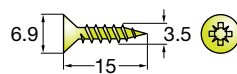

820-6308-050

10000 Pcs

Accessories



Cover caps for hinge arm
→ see page 2.177



Hinge angle restrictor
→ see page 2.175

Legend of hinge cup symbols

Screw-on ready
← screws

Machine insertion ready

EasyFix system

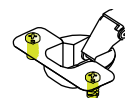
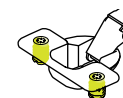

Door adjustment

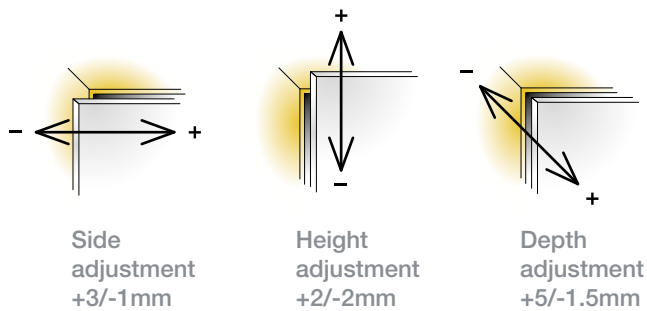

For further explanation → see pages 2.22-2.24

Mounting details

Mounting plate drilling distance

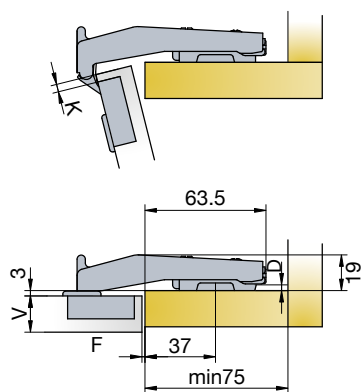

Drawings show application on D=0mm mounting plate

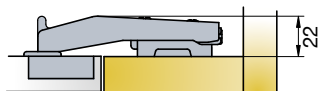

Drawing shows application on D=3mm mounting plate

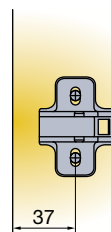

Soft closing systems



Glissando TL3
→ see page 2.189

Touch opening



PushOpen Solutions
→ see pages 2.199-2.204

Door clearance

For further explanation → see page 2.14

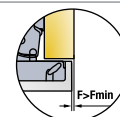

V	16	17	18	19	20	21	22	
3	0.3	0.5	0.7	1.0	1.3	1.7	2.5	
K	4	0.3	0.5	0.7	0.9	1.2	1.6	2.1
5	0.3	0.5	0.7	0.9	1.2	1.5	2.0	F _{MIN}

Gap Z_{MIN}=0

S-type 110 AL

For aluminium frame doors

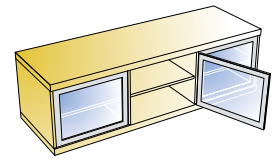
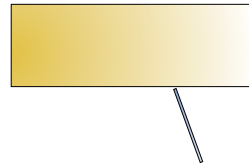
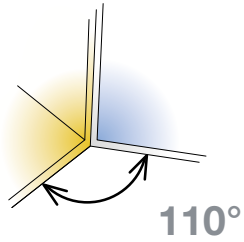

- Opening angle
- Hinge on plate mounting system

110°
snap-on



Interaxis
28mm

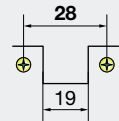

Cup type

Item number

Cranking
0mm

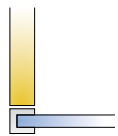

200 Pcs

Cup made of zinc, arm made of steel



950-0T27-050

* Screws included

Cranking
9mm

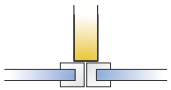

200 Pcs

Cup made of zinc, arm made of steel



950-0T50-050

* Screws included

Cranking
15mm

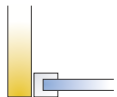

200 Pcs

Cup made of zinc, arm made of steel



950-0T52-050

* Screws included

Mounting plates



Cam adjustable cruciform mounting plate
→ see page 2.127



Cruciform mounting plate
→ see page 2.129



Face frame adapter
→ see page 2.131

Hinge cup screws If not pre-mounted

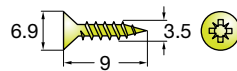

820-6350-050

10000 Pcs

Accessories



Cover caps for hinge arm
→ see page 2.177

Door adjustment

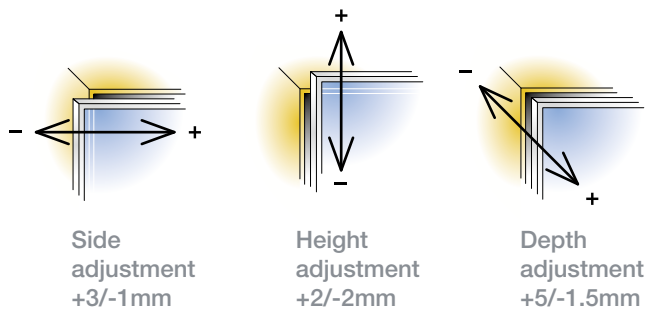

For further explanation → see pages 2.22-2.24

Mounting details

Mounting plate drilling distance

Mounting plate thickness table

For further explanation → see page 2.13

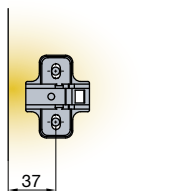
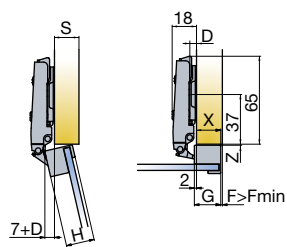

Drawings show application on D=0mm mounting plate

X	12	13	14	15	16	17	18
17	3	2	1	0			
18		3	2	1	0		
19			3	2	1	0	
20				3	2	1	0

D

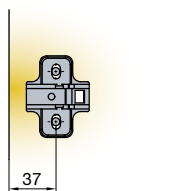
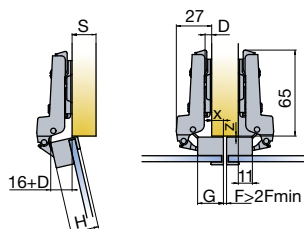

Drawings show application on D=0mm mounting plate

X	3	4	5	6	7	8	9
17	3	2	1	0			
18		3	2	1	0		
19			3	2	1	0	
20				3	2	1	0

D

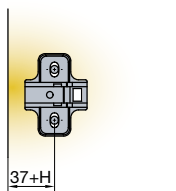
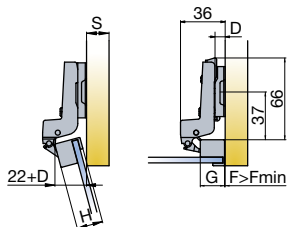

Drawings show application on D=3mm mounting plate

H	17	18	19	20	21	22
17	1	1	2	2	2	3
18	2	2	3	3	3	3
19	3	3	3	3		
20	3	3				

D

Drilling pattern for aluminium frame hinges

Mounting details

Door clearance

For further explanation → see page 2.14

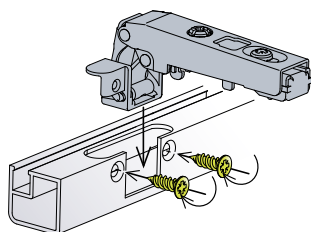
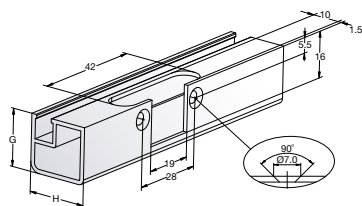

Screws included

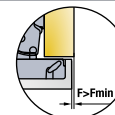

H	17	18	19	20	21	22
17	0.5	0.7	1.1	1.4	1.8	2.9
18	0.5	0.7	1.0	1.3	1.7	2.5
19	0.5	0.7	0.9	1.2	1.6	2.1
20	0.5	0.7	0.9	1.2	1.5	2.0

F_{MIN}

Gap Z_{MIN}=0.5

S-type 110 PushOpen Hinge

For wood doors

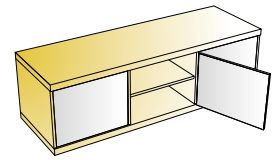
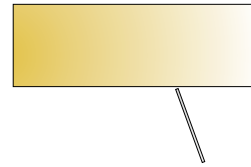
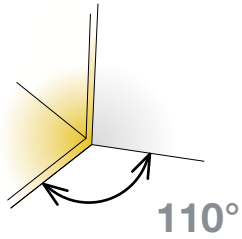

- Opening angle
- Drilling diameter for hinge cup
- Drilling depth
- Hinge on plate mounting system

110°
35mm
11.5mm
snap-on



	Interaxis 45mm	Interaxis 48mm
Cup type		
Item number	915-0Z98-050	915-0Z99-050

Cranking
0mm

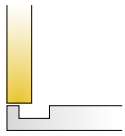

200 Pcs

Made of steel

Cranking
9mm

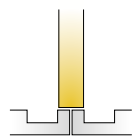

200 Pcs

Made of steel

	915-0Z98-050	915-0Z99-050
--	--------------	--------------

Drilling patterns for hinge cups → see page 2.17

	915-0781-050	915-0896-050
--	--------------	--------------

Drilling patterns for hinge cups → see page 2.17

Mounting plates



Cam adjustable cruciform mounting plate
→ see page 2.127



Steel mounting plate
→ see page 2.129



Face frame adapter
→ see page 2.131

Hinge cup screws

If not pre-mounted

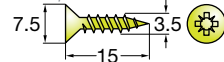

820-6308-050

10000 Pcs

Accessories



Cover caps for hinge arm
→ see page 2.177



Hinge angle restrictor
→ see page 2.175

Legend of hinge cup symbols



Screw-on ready
← screws



- Hinge with reverse spring
- Effortless opening with just a light touch
- Use with PushOpen mechanisms with magnet

→ see pages 2.199-2.204

Door adjustment

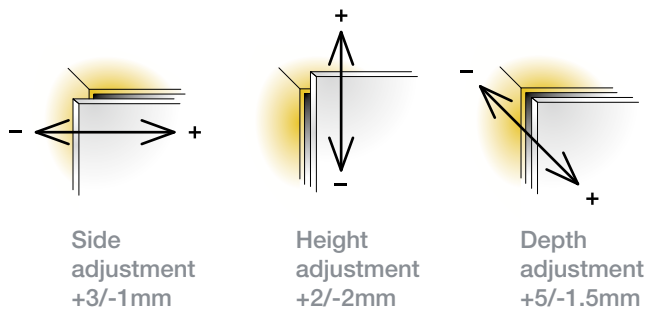

For further explanation → see pages 2.22-2.24

Mounting details

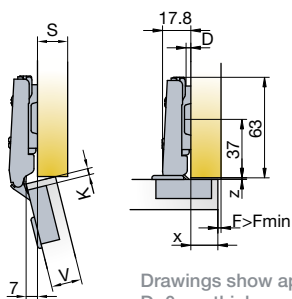

Drawings show application on D=0mm thick mounting plate

Mounting plate drilling distance

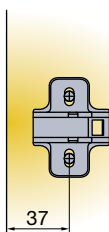

Mounting plate thickness table

For further explanation → see pages 2.13

X	13	14	15	16	17	18
3	3	2	1	0		
K	4	3	2	1	0	
5		3	2	1	0	D

$D=13+K-x$

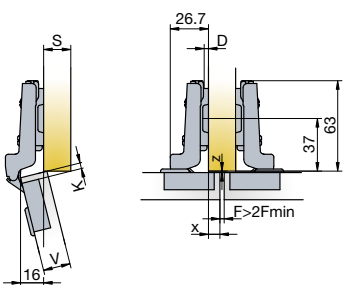

Drawings show application on D=0mm thick mounting plate

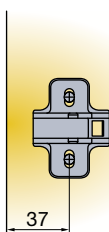

X	4	5	6	7	8	9
3	3	2	1	0		
K	4	3	2	1	0	
5		3	2	1	0	D

$D=4+K-x$

Touch opening



PushOpen Solutions
→ see pages 2.199-2.204

Door clearance at R=1mm

For further explanation → see pages 2.14

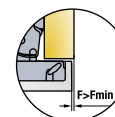

V	16	17	18	19	20	21	22	
3	0.3	0.5	0.7	1.0	1.3	1.7	2.5	
K	4	0.3	0.5	0.7	0.9	1.2	1.6	2.1
5	0.3	0.5	0.7	0.9	1.2	1.5	2.0	F _{MIN}

Gap Z_{MIN}=0

S-type 170

For wood doors

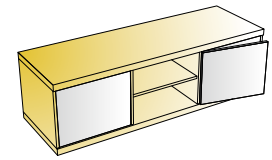
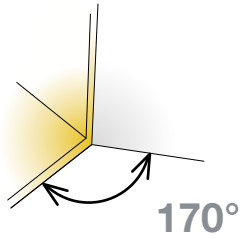

- Opening angle
- Drilling diameter for hinge cup
- Drilling depth
- Hinge on plate mounting system

170°
35mm
12mm
snap-on



Cup type	Interaxis 45mm	Interaxis 48mm
Item number	Item number	Item number
	248-0R14-050	248-0R17-050
	248-0M73-050	248-0R13-050

Drilling patterns for hinge cups → see page 2.17

Cranking
0mm

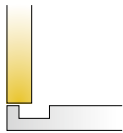

50 Pcs

Made of steel and zinc

Mounting plates



Cam adjustable cruciform mounting plate
→ see page 2.127



Cruciform mounting plate
→ see page 2.129



Face frame adapter
→ see page 2.131

Hinge cup screws If not pre-mounted

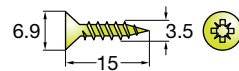

820-6308-050

10000 Pcs

Accessories



Hinge angle restrictor
→ see page 2.175

Legend of hinge cup symbols

Screw-on ready
← screws

Machine insertion ready

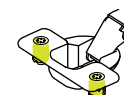

Door adjustment

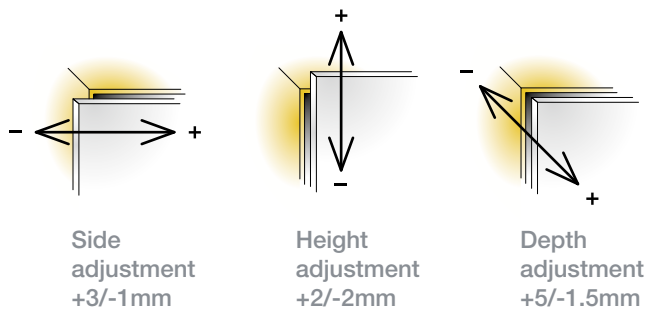

For further explanation → see pages 2.22-2.24

Mounting details

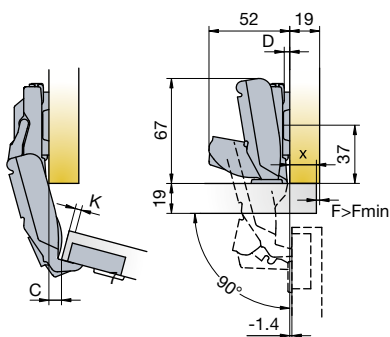

Drawings show application on D=0mm mounting plate
No protrusion in 90° position

Mounting plate drilling distance

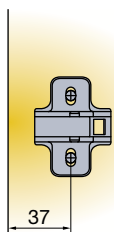

Mounting plate thickness table

For further explanation → see page 2.13

X	10	11	12	13	14	15	16	17	18	19	20
3	6	5	4	3	2	1	0				
4		6	5	4	3	2	1	0			
K 5			6	5	4	3	2	1	0		
6				6	5	4	3	2	1	0	
7					6	5	4	3	2	1	0 D

$D=13+K-X$

C value with D=0 mounting plates

K	3	4	5	6	7
C	-9.0	-8.1	-7.1	-6.1	-5.2 D

Soft closing systems



Glissando TL 170
→ see page 2.191

Glissando CR
→ see page 2.195

Touch opening



PushOpen Solutions
→ see pages 2.199-2.204

Door clearance

For further explanation → see page 2.14

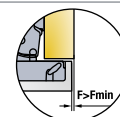

V	16	17	18	19	20	21	22	23	24
3	0.0	0.0	0.0	0.0	0.0	0.0	0.0	0.0	0.0
4	0.0	0.0	0.0	0.0	0.0	0.0	0.0	0.0	0.0
K 5	0.0	0.0	0.0	0.0	0.0	0.0	0.0	0.0	0.0
6	0.0	0.0	0.0	0.0	0.0	0.0	0.0	0.0	2.6
7	0.0	0.0	0.0	0.0	0.0	0.0	0.0	0.0	5.1 F _{MIN}

Gap Z_{MIN}=0.5

S-type 170

For wood doors

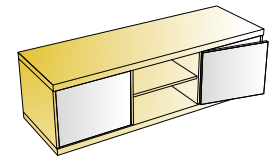
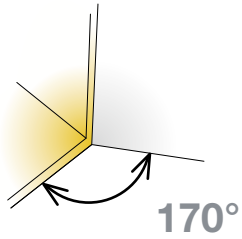

- Opening angle
- Drilling diameter for hinge cup
- Drilling depth
- Hinge on plate mounting system

170°
35mm
12mm
snap-on



	Interaxis 45mm	Interaxis 48mm
Cup type		
Item number	248-0162-050	248-0163-050

Drilling patterns for hinge cups → see page 2.17

Cranking
9mm

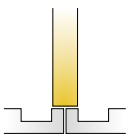

50 Pcs

Made of steel and zinc

Mounting plates



Cam adjustable cruciform mounting plate
→ see page 2.127



Cruciform mounting plate
→ see page 2.129



Face frame adapter
→ see page 2.131

Hinge cup screws

If not pre-mounted

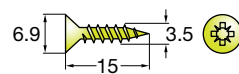

820-6308-050

10000 Pcs

Accessories



Hinge angle restrictor
→ see page 2.175

Legend of hinge cup symbols

Screw-on ready
← screws



Door adjustment

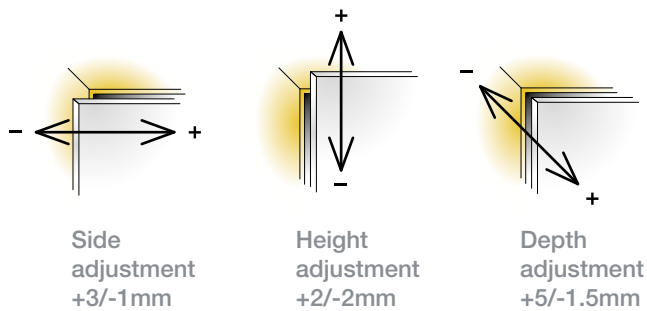

For further explanation → see pages 2.22-2.24

Mounting details

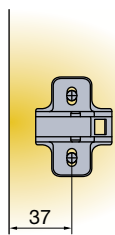
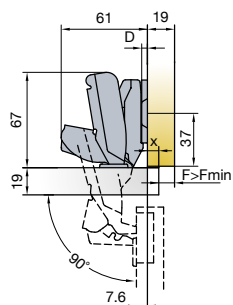
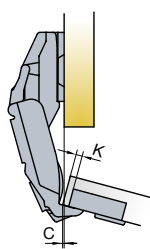

Drawings show application on D=0mm mounting plate

Mounting plate drilling distance

Mounting plate thickness table

For further explanation → see page 2.13

X	1	2	3	4	5	6	7	8	9	10	11
3	6			3	2	1	0				
4		6			3	2	1	0			
K 5			6			3	2	1	0		
6				6			3	2	1	0	
7					6			3	2	1	0

$D=4+K-X$

C value with D=0 mounting plates

K	3	4	5	6	7
C	0	0.9	1.9	2.9	3.8

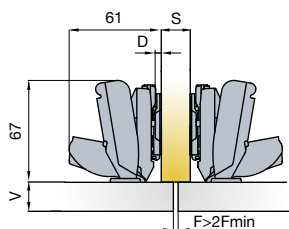

Drawing shows application on D=0mm mounting plate

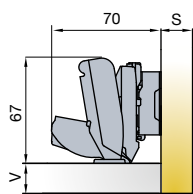

Drawing shows application on D=9mm mounting plate

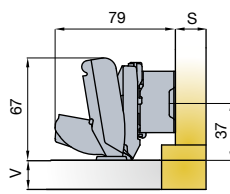

Drawing shows application on D=18mm mounting plate

Soft closing systems



Glissando TL 170
→ see page 2.191



Glissando CR
→ see page 2.195

Touch opening



PushOpen Solutions
→ see pages 2.199-2.204

Door clearance

For further explanation → see page 2.14

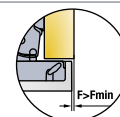

V	16	17	18	19	20	21	22	23	24
3	0.0	0.0	0.0	0.0	0.0	0.0	0.0	0.0	0.0
4	0.0	0.0	0.0	0.0	0.0	0.0	0.0	0.0	0.0
K 5	0.0	0.0	0.0	0.0	0.0	0.0	0.0	0.0	0.0
6	0.0	0.0	0.0	0.0	0.0	0.0	0.0	0.0	2.6
7	0.0	0.0	0.0	0.0	0.0	0.0	0.0	0.0	5.1 F _{MIN}

Gap Z_{MIN}=0.5

S-type

for Pie-cut Corner Cabinet

For wood doors

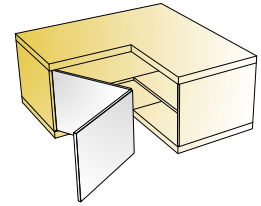

- Opening angle 110°
- Drilling diameter for hinge cup 35mm
- Drilling depth 11.5mm
- Hinge on plate mounting system snap-on



	Interaxis 45mm	Interaxis 48mm
Cup type	Item number	Item number
	248-0U21-050	248-0U16-050
	248-0U22-050	248-0V15-050

Corner cabinet

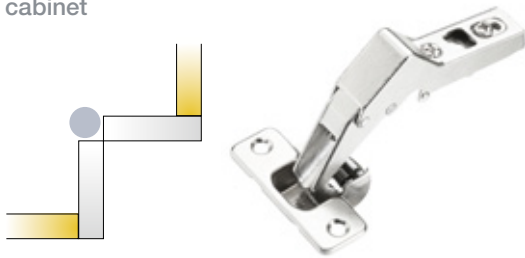

Drilling patterns for hinge cups → see page 2.17

100 Pcs Cup made of steel, arm made of zinc

Mounting plates



Cam adjustable cruciform mounting plate
→ see page 2.127



Cruciform mounting plate
→ see page 2.129

Hinge cup screws

If not pre-mounted

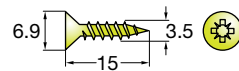

820-6308-050

10000 Pcs

Accessories



Cover caps for hinge arm
→ see page 2.177

Legend of hinge cup symbols

Screw-on ready
← screws

Machine insertion ready

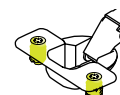

Door adjustment

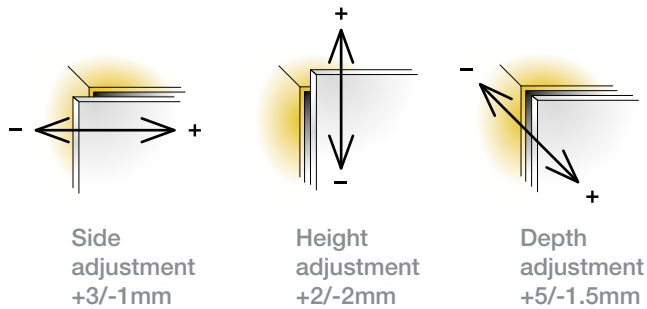

For further explanation → see pages 2.22-2.24

Mounting details

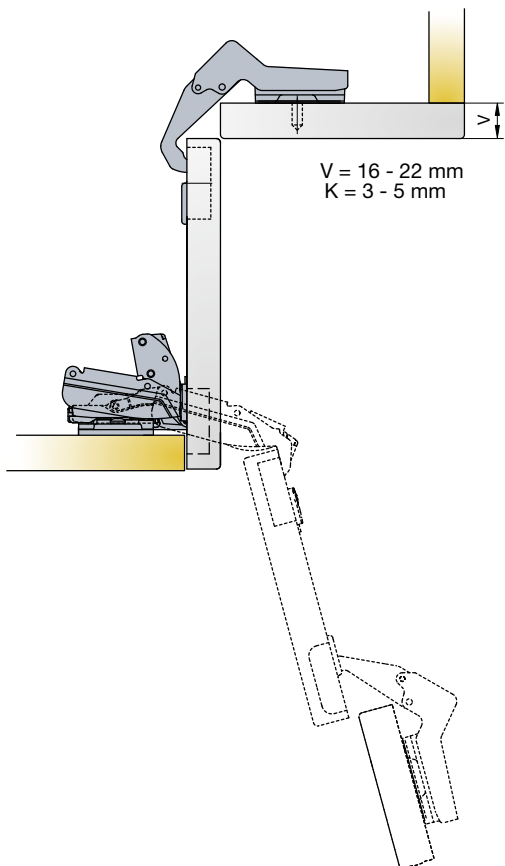

Mounting plate drilling distance

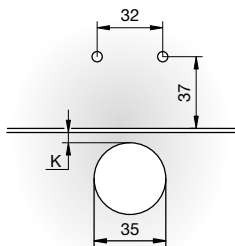

Adjustments

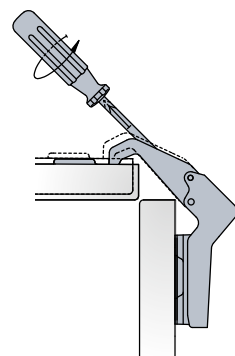

The diagonal adjustment is made by rotating the appropriate screw as shown on the drawing

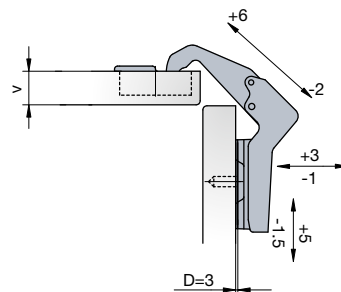

Touch opening



PushOpen Solutions
→ see pages 2.199-2.204

S-type Mounting Plates

S-type snap-on mounting

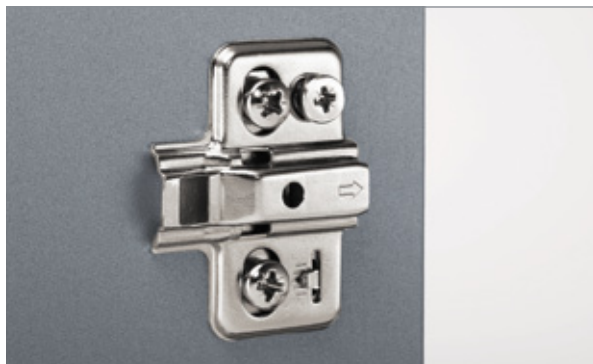
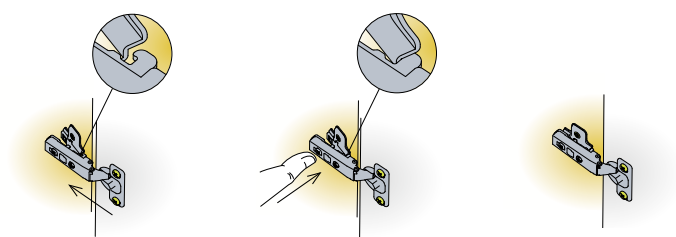

Cam adjustable cruciform
mounting plate 37mm

Drilling pattern

Dimensions

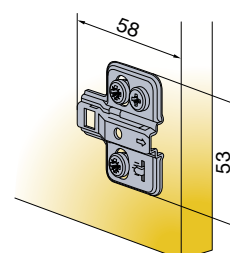
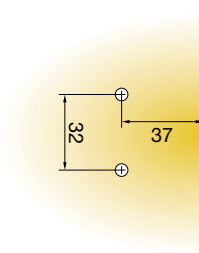

 200 Pcs Made of steel

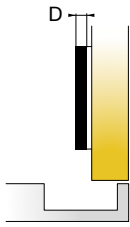

Mounting plate thickness

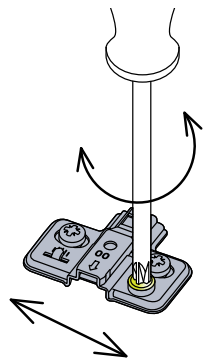

Height adjustment +/- 2mm

Mounting plate type	13	15			10.5	
Mounting plate thickness (D)						
Item number						
0mm	244-0258-050	244-0261-050	*244-0264-050	*244-0342-050	244-0270-050	
2mm	244-0259-050	244-0262-050	*244-0265-050	*244-0343-050	244-0271-050	
3mm	244-0260-050	244-0263-050	*244-0266-050	*244-0344-050	244-0272-050	
* Available upon special request → see page 0.3						

Legend of mounting plate type symbols



13

Pre-mounted
13mm euro screws



15

Pre-mounted
15mm euro screws



Pre-mounted
chipboard screws



Machine
insertion ready



10.5

Pre-mounted
10.5mm
expanding dowels

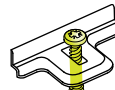
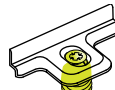
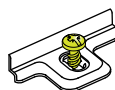
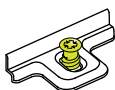
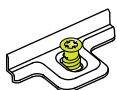

S-type Mounting Plates

S-type snap-on mounting

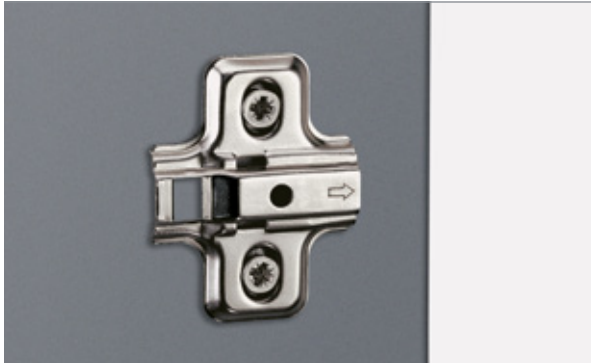
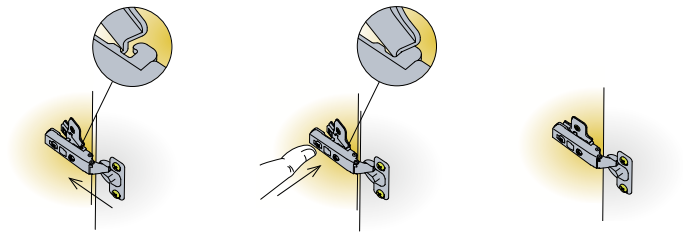

Cruciform mounting plate

Drilling pattern

Dimensions

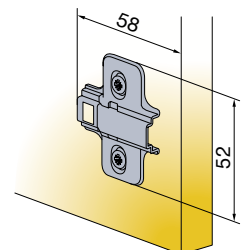
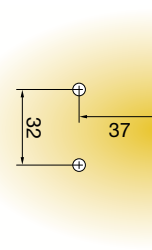

200 Pcs Made of steel

Zinc diecast cruciform mounting plate 37mm

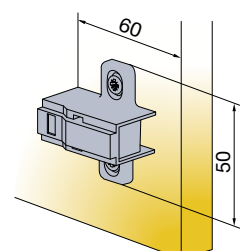
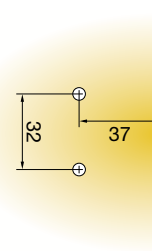

200 Pcs Made of zinc

Fixing screws for mounting plates
If not pre-mounted

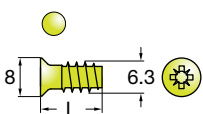

Euro screws
821-6304-050 L=11
821-6323-050 L=13
821-6332-050 L=15

5000 Pcs

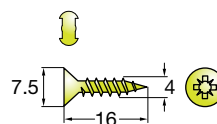

Chipboard screws
820-6328-050

10000 Pcs

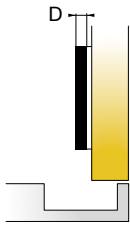

Mounting plate thickness

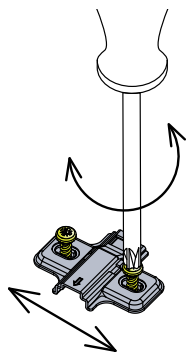

Height adjustment +/- 2mm

Mounting plate type								
Mounting plate thickness (D)								
Item number								
0mm	244-1136-050	*244-1233-050	244-0Z26-050	244-0134-050	244-0118-050	*244-0136-050	*244-0166-050	244-0P26-050
1mm	244-1137-050	*244-1228-050		244-0561-050		*244-0565-050	*244-0567-050	
2mm	244-1138-050	*244-1229-050	244-0Z63-050	244-0562-050	244-0120-050	*244-0566-050	*244-0568-050	244-0V19-050
3mm	244-1139-050	*244-1234-050		244-0135-050	244-0119-050	*244-0137-050	*244-0167-050	244-0P27-050
6mm	244-1645-050				244-0Z51-050			
<p>* Available upon special request → see page 0.3 Mounting plates with pre-mounted 7.5mm expanding dowels available upon special request → see page 0.3</p>								
9mm	244-3651-650			244-0M33-650	244-0P29-650			
18mm	244-3016-650			244-0085-650	244-0095-650			

Legend of mounting plate type symbols

Screw on ready for euro screws ← screws	Screw-on ready for chipboard ← screws	Pre-mounted 11mm euro screws	Pre-mounted 13mm euro screws	Pre-mounted 15mm euro screws	Pre-mounted chipboard screws	Machine insertion ready	Pre-mounted 10.5mm expanding dowels

S-type

Face Frame

Mounting Plates

S-type snap-on mounting

Drilling pattern

Dimensions

Face frame adapter for
S-type hinges

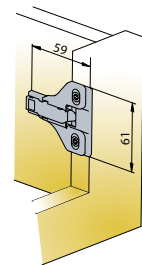
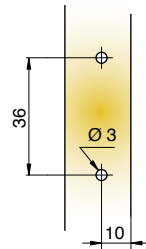

 200 Pcs Made of zinc alloy

Face frame adapter for
S-type hinges
cam adjustable

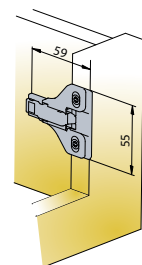
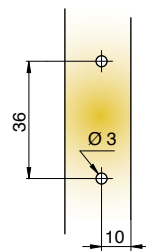

 200 Pcs Made of zinc alloy

Fixing screw for mounting plates
If not pre-mounted

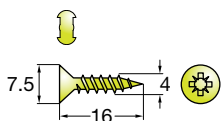

Chipboard screws
820-6328-050

 10000 Pcs

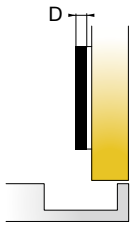

Mounting plate thickness

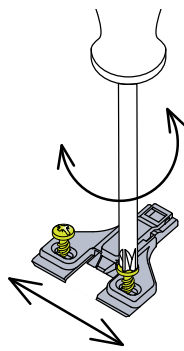

Height adjustment +/- 2mm

Mounting plate type		
		
Mounting plate thickness (D)	Item number	
0mm	244-3653-650	
3mm	244-3654-650	
6mm	244-3655-650	
0mm	244-3600-650	
3mm	244-3603-650	

Legend of mounting plate type symbols



Screw-on ready for chipboard screws
 ← screws

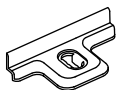



B-type Hinges

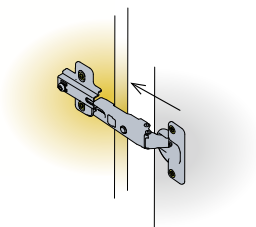

Slide-on mounting system

- Proven and reliable hinge-to-plate mounting solution
- Cost-per-door effectiveness
- Proven solution for RTA furniture, household application and tall cabinets

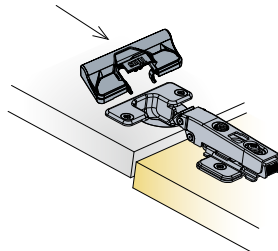

Soft closing options

- Hinge integrated
- Stand-alone
- Add-on with Glissando ready hinge cup
- Fast and simple mounting

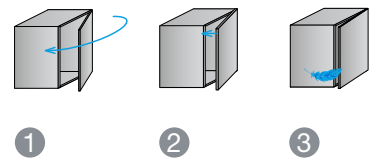

ConfidentClose

- 1 Fast closing
- 2 Late start of deceleration action
- 3 Quiet landing with SoftTouch

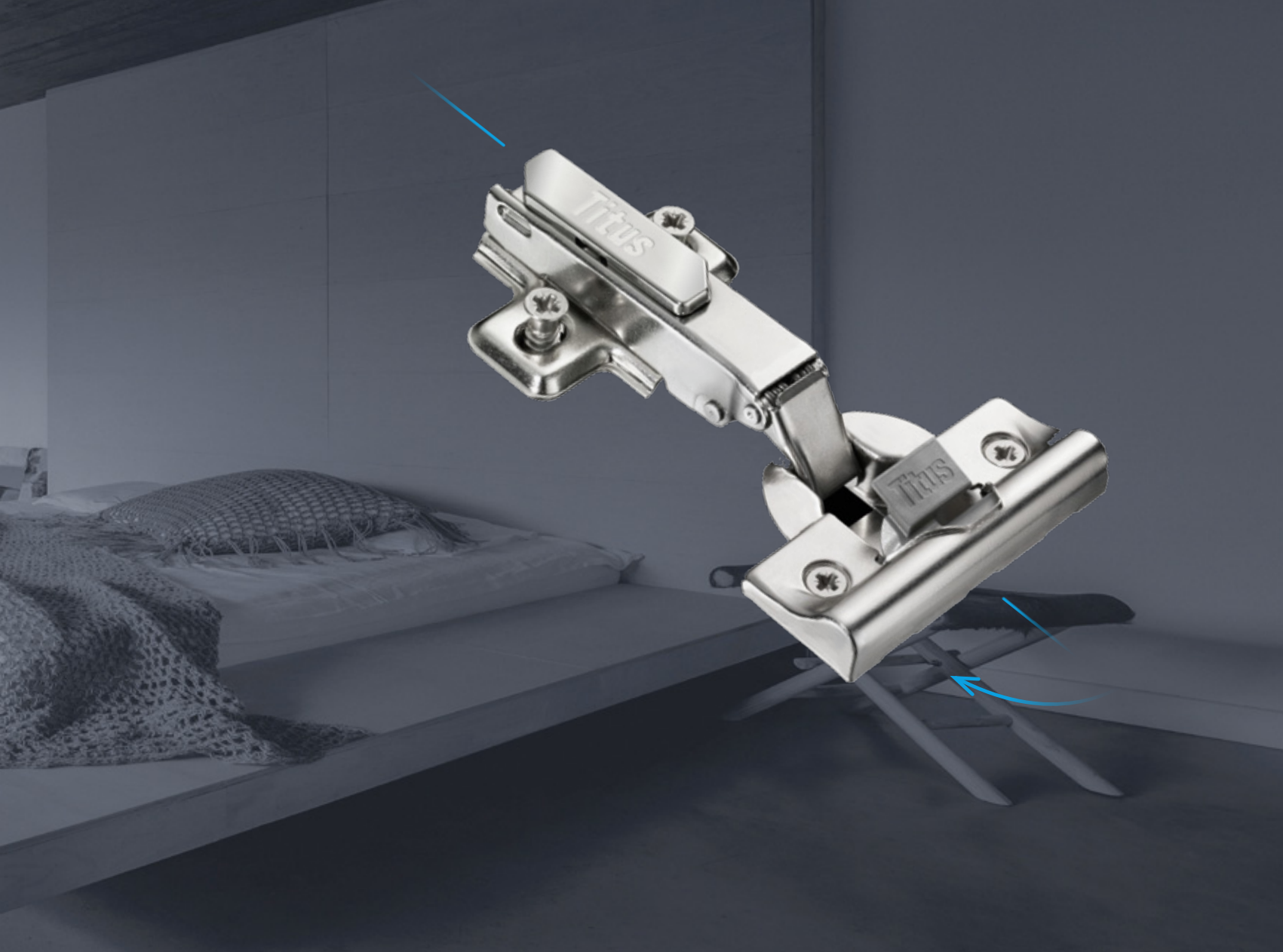

Titus Damper Inside

- Titus proprietary multi-purpose damping technology
- Reliable and consistent life-long damping

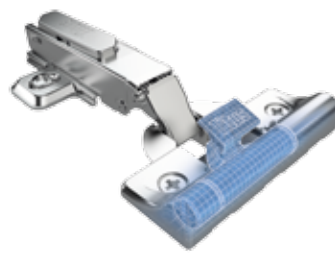

B-type-i3

- Reliable open-close
- Consistent performance
- ConfidentClose
- Low 11mm hinge depth cup

B-type-i3 110

For wood doors

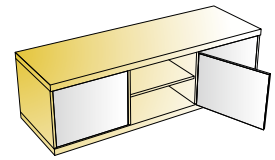
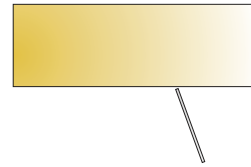
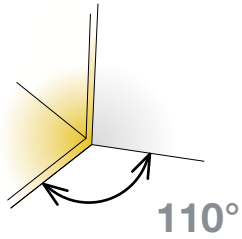

- Opening angle
- Drilling diameter for hinge cup
- Drilling depth
- Hinge on plate mounting system

110°
35mm
min. 11mm
slide-on



Technical details

Cup type

Interaxis
45mm

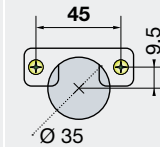

Item number

242-0967-054

Interaxis
48mm

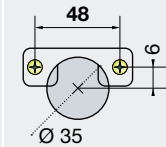

Item number

242-0968-054

Cranking
0mm

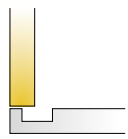

200 Pcs



Made of steel and plastic

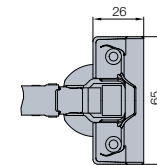
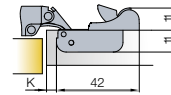

Drilling patterns for hinge cups → see page 2.17

Cranking
9mm

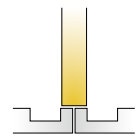

200 Pcs



Made of steel and plastic

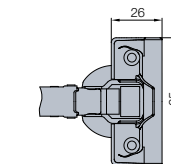
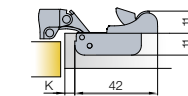

242-0973-054

242-0974-054

Drilling patterns for hinge cups → see page 2.17

Cranking
15mm

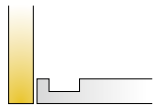

200 Pcs



Made of steel and plastic

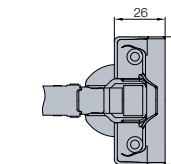
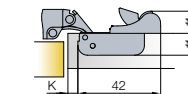

242-0979-054

242-0980-054

Drilling patterns for hinge cups → see page 2.17

Mounting plates



Cruciform mounting plate
→ see page 2.167

Hinge cup screws
If not pre-mounted

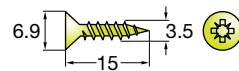

820-6308-050

10000 Pcs

Legend of hinge cup symbols

 Screw-on ready
← screws

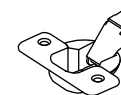

Accessories



Cover caps for hinge arm
→ see page 2.177



Hinge angle restrictor
→ see page 2.175

Door adjustment

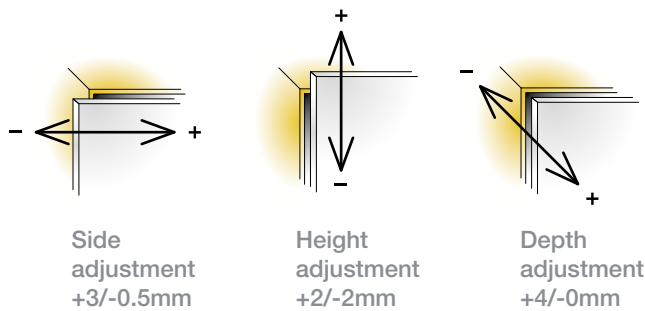

For further explanation → see pages 2.22-2.24

Mounting details

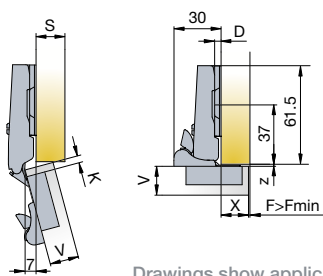

Drawings show application on D=0mm mounting plate

Mounting plate drilling distance

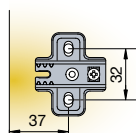

Mounting plate thickness table

For further explanation → see page 2.13

X	10	11	12	13	14	15	16	17	18
3	6	5	4	3	2	1	0	0	
K	4	6	5	4	3	2	1	0	0
5		6	5	4	3	2	1	0	D

$D=13+K-X$

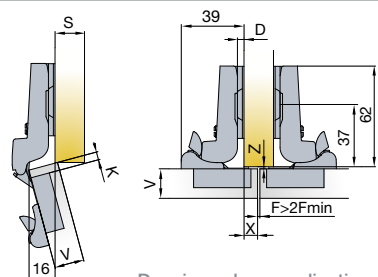

Drawings show application on D=0mm mounting plate

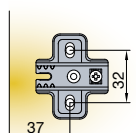

X	0	1	2	3	4	5	6	7	8	9
3		6	5	4	3	2	1	0		
K	4		6	5	4	3	2	1	0	
5	9		6	5	4	3	2	1	0	D

$D=4+K-X$

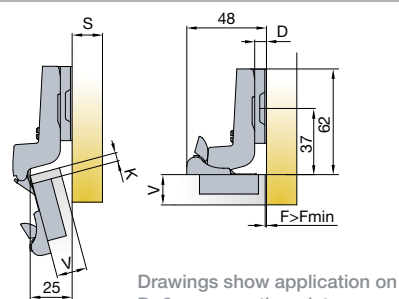

Drawings show application on D=3mm mounting plate

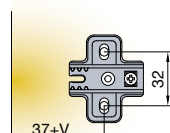

V	16	17	18	19	20	21	22
3	2	2	2	3	3	3	4
K	4	3	3	3	4	4	5
5	4	4	4	5	5	5	6

$D=-2+K+F$

Touch opening



PushOpen Solutions
→ see pages 2.199-2.204

Door clearance

For further explanation → see page 2.14

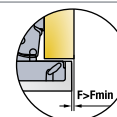

V	16	17	18	19	20	21	22
3	0.3	0.5	0.7	1.0	1.3	1.7	2.5
K	4	0.3	0.5	0.7	0.9	1.2	1.6
5	0.3	0.5	0.7	0.9	1.2	1.5	2.0

Gap $Z_{MIN}=0$

B-type-i3 110/30°

30° angled application for wood doors

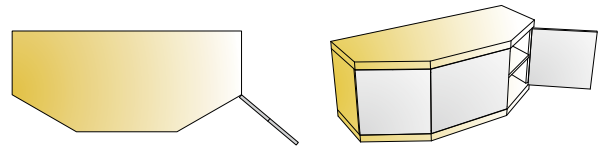
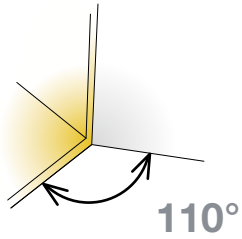

- Opening angle
- Drilling diameter for hinge cup
- Drilling depth
- Hinge on plate mounting system

110°
35mm
min. 11mm
slide-on



Technical details

	Interaxis 45mm	Interaxis 48mm
Cup type		
Item number		

Cranking
9mm

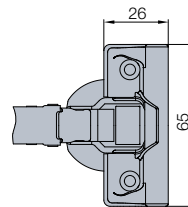
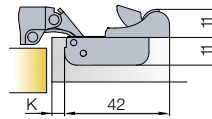
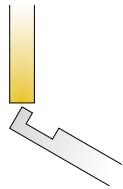

Cup type		
Item number	242-0924-650	242-0H34-650

Drilling patterns for hinge cups → see page 2.17

100 Pcs

Cup made of steel and plastic, arm made of zinc

Mounting plates



Cruciform mounting plate
→ see page 2.167

Hinge cup screws

If not pre-mounted

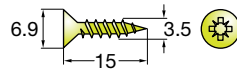

820-6308-050

10000 Pcs

Legend of hinge cup symbols

Screw-on ready
← screws



Accessories



Cover caps for hinge arm
→ see page 2.177



Hinge angle restrictor
→ see page 2.175

Door adjustment

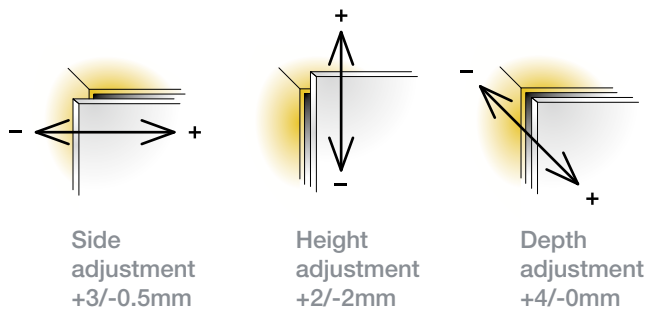

For further explanation → see pages 2.22-2.24

Mounting details

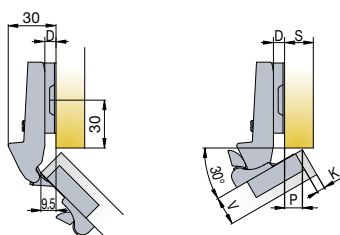

Mounting plate drilling distance

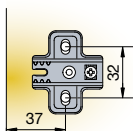

Mounting plate thickness table

For further explanation → see page 2.13

P	2.5	3.5	4.5	8.5	9.5	10.5	11.5	12.5	13.5
3	9			3	2	1	0		
K 4		9			3	2	1	0	
5			9			3	2	1	0 D

Drawings show application on D=3mm mounting plate

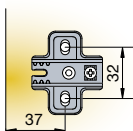
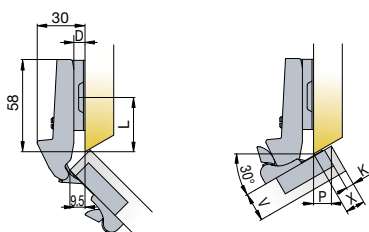

X	2	3	4	9	10	11	12	13	14	15
3	9			3	2			0		
K 4		9			3	2			0	
5			9			3	2			0 D

L=37 for thickness D=0
 L=36 for thickness D=1
 L=35 for thickness D=2
 L=34 for thickness D=3
 L=31 for thickness D=9

Drawings show application on D=3mm mounting plate

Touch opening



PushOpen Solutions
 → see pages 2.199-2.204

Door clearance

For further explanation → see page 2.14

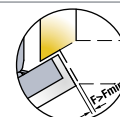

V	16	17	18	19	20	21	22
3	0.3	0.5	0.7	1.0	1.3	1.7	2.5
K 4	0.3	0.5	0.7	0.9	1.2	1.6	2.1
5	0.3	0.5	0.7	0.9	1.2	1.5	2.0 F _{MIN}

Gap Z_{MIN}=0

B-type-i3 110/45°

45° angled application for wood doors

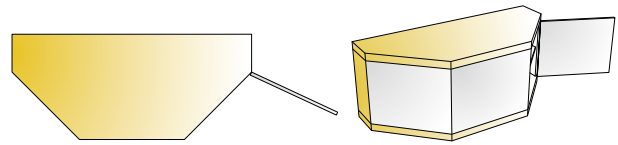
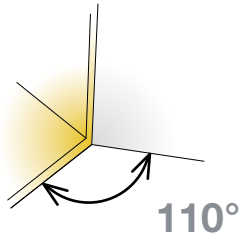

- Opening angle
- Drilling diameter for hinge cup
- Drilling depth
- Hinge on plate mounting system

110°
35mm
min. 11mm
slide-on



Technical details

	Interaxis 45mm	Interaxis 48mm
Cup type		
Item number	242-0C27-650	242-0D14-650

Cranking
9mm

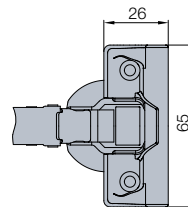
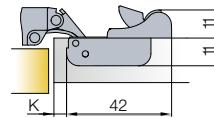
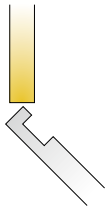

Drilling patterns for hinge cups → see page 2.17

200 Pcs

Cup made of steel and plastic, arm made of zinc

Mounting plates



Cruciform mounting plate
→ see page 2.167

Hinge cup screws

If not pre-mounted

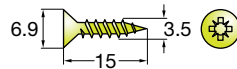

820-6308-050

10000 Pcs

Accessories



Cover caps for hinge arm
→ see page 2.177



Hinge angle restrictor
→ see page 2.175

Legend of hinge cup symbols

Screw-on ready
← screws



Door adjustment

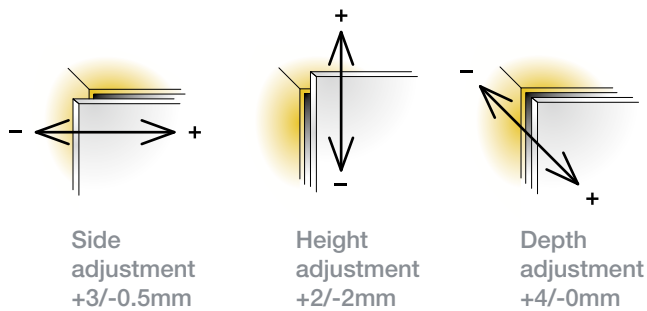

For further explanation → see pages 2.22-2.24

Mounting details

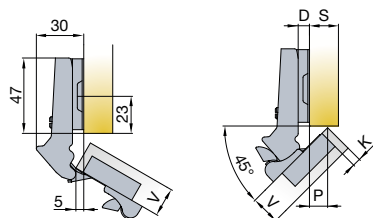

Mounting plate drilling distance

Mounting plate thickness table
For further explanation → see page 2.13

P	9	9.5	10	10.5	11	11.5	12	12.5	13.5
3	3		2		1		0		
K 4		3		2		1		0	
5				3		2		1	0 D

Drawings show application on D=3mm mounting plate

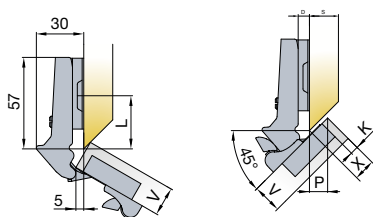

X 11.5 12.5 13 13.5 14 14.5 15 15.5 16 16.5 17 18

X	11.5	12.5	13	13.5	14	14.5	15	15.5	16	16.5	17	18
3	3		2			1			0			
K 4		3			2			1			0	
5				3			2			1		0 D

L=36 for thickness D=0
L=35 for thickness D=1
L=34 for thickness D=2
L=33 for thickness D=3

Drawings show application on D=3mm mounting plate

Touch opening



PushOpen Solutions
→ see pages 2.199-2.204

Door clearance

For further explanation → see page 2.14

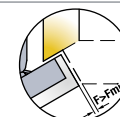

V	16	17	18	19	20	21	22
3	0.3	0.5	0.7	1.0	1.3	1.7	2.5
K 4	0.3	0.5	0.7	0.9	1.2	1.6	2.1
5	0.3	0.5	0.7	0.9	1.2	1.5	2.0 F _{MIN}

Gap Z_{MIN}=0

B-type-i3 110/45°

45° angled application for wood doors

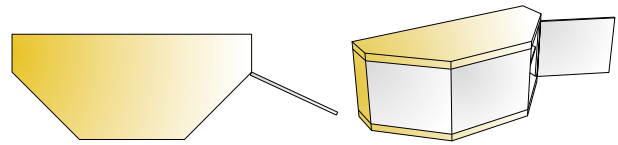
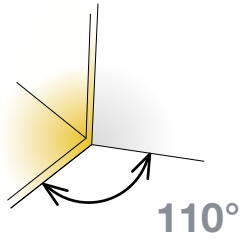

- Opening angle
- Drilling diameter for hinge cup
- Drilling depth
- Hinge on plate mounting system

110°
35mm
min. 11mm
slide-on



Technical details

	Interaxis 45mm	Interaxis 48mm
Cup type		
Item number		

Cranking
18mm

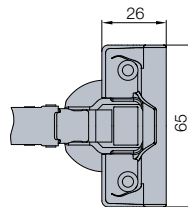
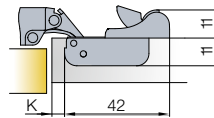
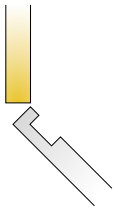

Cup type		
Item number	242-0H48-650	242-0H49-650

Drilling patterns for hinge cups → see page 2.17

200 Pcs

Cup made of steel and plastic, arm made of zinc

Mounting plates



Cruciform mounting plate
→ see page 2.167

Hinge cup screws

If not pre-mounted

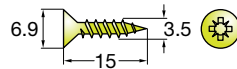

820-6308-050

10000 Pcs

Legend of hinge cup symbols

Screw-on ready
← screws



Accessories



Cover caps for hinge arm
→ see page 2.177



Hinge angle restrictor
→ see page 2.175

Door adjustment

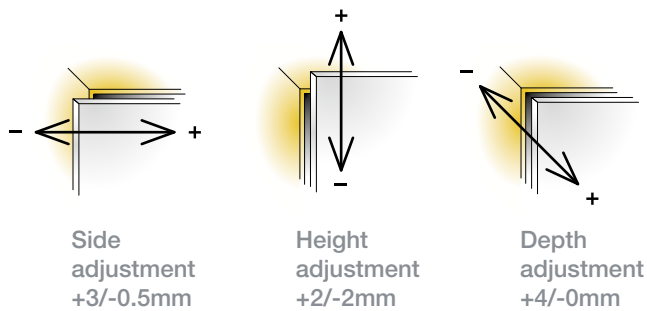

For further explanation → see pages 2.22-2.24

Mounting details

Mounting plate drilling distance

Mounting plate thickness table
For further explanation → see page 2.13

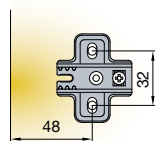
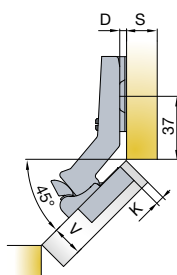
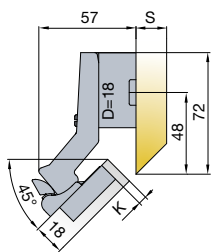

Drawing shows application on D=18mm mounting plate

Drawing shows application on D=0mm mounting plate

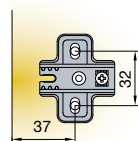
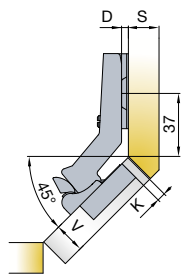
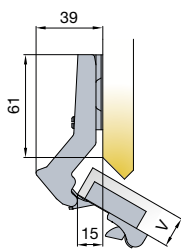

	3	0
K	4	1
	5	2
		D

Drawings show application on D=0mm mounting plate

L=36 for thickness D=0
L=35 for thickness D=1
L=34 for thickness D=2
L=33 for thickness D=3

Touch opening



PushOpen Solutions
→ see pages 2.199-2.204

Door clearance

For further explanation → see page 2.14

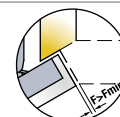

V	16	17	18	19	20	21	22	
3	0.3	0.5	0.7	1.0	1.3	1.7	2.5	
K	4	0.3	0.5	0.7	0.9	1.2	1.6	2.1
5	0.3	0.5	0.7	0.9	1.2	1.5	2.0	F _{MIN}

Gap Z_{MIN}=0

B-type-i3 110/90°

For wood door cabinets with blind panels

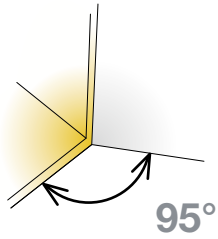
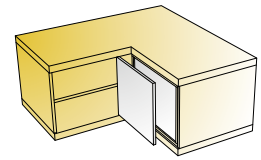

- Opening angle
- Drilling diameter for hinge cup
- Drilling depth
- Hinge on plate mounting system

95°
35mm
min. 11mm
slide-on



Technical details

Cup type	Interaxis 45mm	Interaxis 48mm
	Item number	Item number

Cranking
18mm

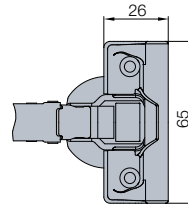
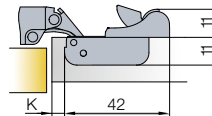
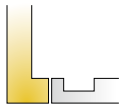

	242-0Y48-650	242-0Y49-650
--	--------------	--------------

Drilling patterns for hinge cups → see page 2.17

200 Pcs

Cup made of steel and plastic, arm made of zinc

Blind panel
mounting
plate



	244-0810-650	
	15 244-0P28-650	
	13 244-0C32-650	

This mounting plate can be only used with B-type-i 110/90° hinges.
Information about mounting plate symbols → see page 2.168

200 Pcs

Made of zinc

Mounting plates



These hinges can only be used with blind panel mounting plates

Hinge cup screws
If not pre-mounted

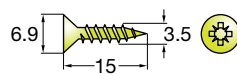

820-6308-050

10000 Pcs

Accessories



Cover caps for hinge arm
→ see page 2.177



Hinge angle restrictor
→ see page 2.175

Legend of hinge cup symbols

Screw-on ready
← screws



Door adjustment

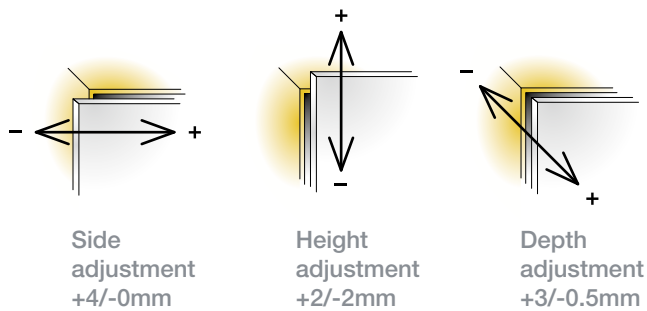

For further explanation → see pages 2.22-2.24

Mounting details

Mounting plate drilling distance

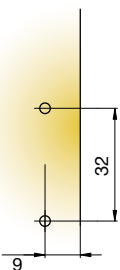
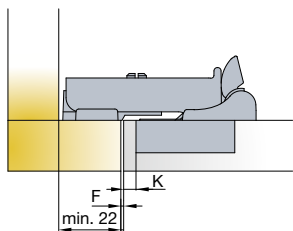

Glissando CR
→ see page 2.195

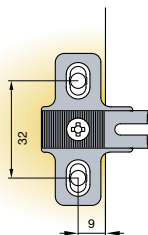

Touch opening



PushOpen Solutions
→ see pages 2.199-2.204

Door clearance

For further explanation → see page 2.14

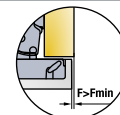

V	16	17	18	19	20	21	22	
3	0.3	0.5	0.7	1.0	1.3	1.7	2.5	
K	4	0.3	0.5	0.7	0.9	1.2	1.6	2.1
5	0.3	0.5	0.7	0.9	1.2	1.5	2.0	F _{MIN}

Gap Z_{MIN}=0

B-type 110

For wood doors

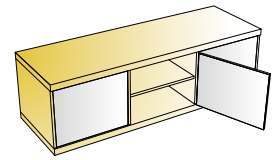
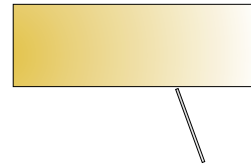
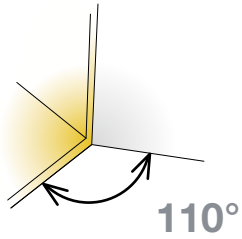

- Opening angle
- Drilling diameter for hinge cup
- Drilling depth
- Hinge on plate mounting system

110°
35mm
min. 11.5mm
slide-on



Technical details

Cup type	Interaxis 45mm	Interaxis 48mm
	Item number 248-0G54-050	Item number 248-0G49-050
	Item number 248-0G79-050	Item number 248-0K40-050

Drilling patterns for hinge cups → see page 2.17

Cranking
0mm

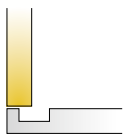

200 Pcs

Made of steel

Cranking
9mm

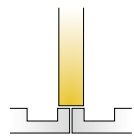

200 Pcs

Made of steel

Cranking
15mm

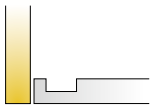

200 Pcs

Made of steel

	248-0G55-050	248-0G50-050
	248-0G80-050	248-0K76-050

Drilling patterns for hinge cups → see page 2.17

	248-0G56-050	248-0G51-050
	248-0G81-050	248-0L04-050

Drilling patterns for hinge cups → see page 2.17

Mounting plates



Cruciform mounting plate
→ see page 2.167

Hinge cup screws

If not pre-mounted

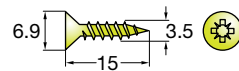

820-6308-050

10000 Pcs

Accessories



Cover caps for hinge arm
→ see page 2.177



Hinge angle restrictor
→ see page 2.175

Legend of hinge cup symbols

Screw-on ready
← screws

Machine insertion ready

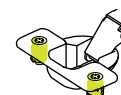

Door adjustment

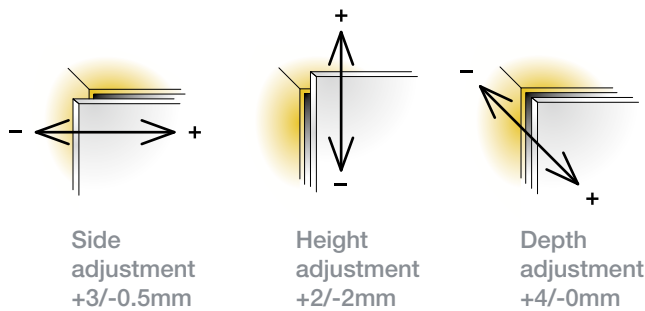

For further explanation → see pages 2.22-2.24

Mounting details

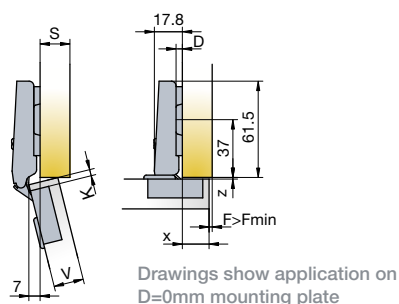

Mounting plate drilling distance

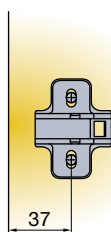

Mounting plate thickness table

For further explanation → see page 2.13

X	10	11	12	13	14	15	16	17	18
3	6	5	4	3	2	1	0	0	
K	4	6	5	4	3	2	1	0	0
5		6	5	4	3	2	1	0	D

$D=13+K-X$

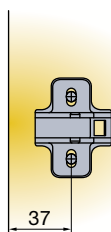
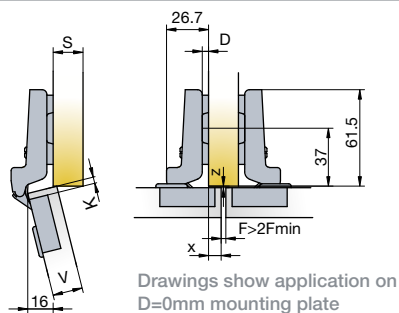

X	0	1	2	3	4	5	6	7	8	9
3		6	5	4	3	2	1	0		
K	4		6	5	4	3	2	1	0	
5	9		6	5	4	3	2	1	0	D

$D=4+K-X$

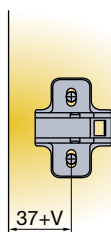
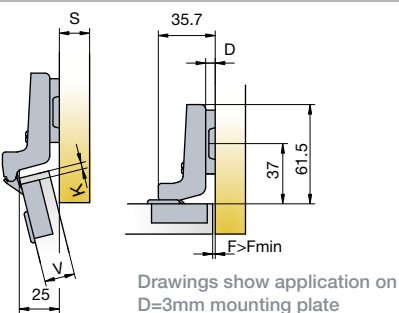

V	16	17	18	19	20	21	22
3	2	2	2	3	3	3	4
K	4	3	3	3	4	4	5
5	4	4	4	5	5	5	6

$D=-2+K+F$

Soft closing systems



Glissando TL3
→ see page 2.189



Glissando CR
→ see page 2.195

Touch opening



PushOpen Solutions
→ see pages 2.199-2.204

Door clearance

For further explanation → see page 2.14

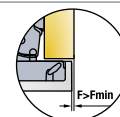

V	16	17	18	19	20	21	22
3	0.3	0.5	0.7	1.0	1.3	1.7	2.5
K	4	0.3	0.5	0.7	0.9	1.2	1.6
5	0.3	0.5	0.7	0.9	1.2	1.5	2.0

Gap $Z_{MIN}=0$

B-type 110/30°

30° angled application for wood doors

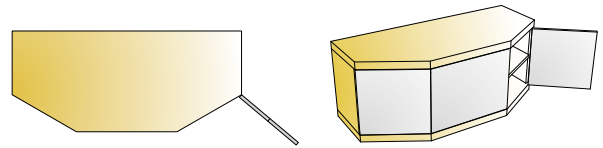
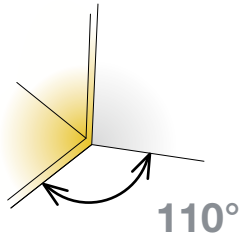

- Opening angle 110°
- Drilling diameter for hinge cup 35mm
- Drilling depth 11.5mm
- Hinge on plate mounting system slide-on



Technical details

Cup type	Interaxis 45mm	Interaxis 48mm
Item number	Item number	Item number
	248-0G57-050	248-0G52-050
	248-0G82-050	248-0L72-050

Drilling patterns for hinge cups → see page 2.17

Cranking
9mm

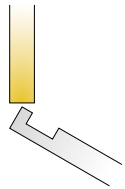

200 Pcs

Cup made of steel, arm made of zinc

Mounting plates



Cruciform mounting plate
→ see page 2.167

Hinge cup screws

If not pre-mounted

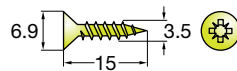

820-6308-050

10000 Pcs

Accessories



Cover caps for hinge arm
→ see page 2.177



Hinge angle restrictor
→ see page 2.175

Legend of hinge cup symbols

Screw-on ready
← screws

Machine insertion ready

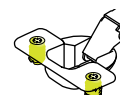

Door adjustment

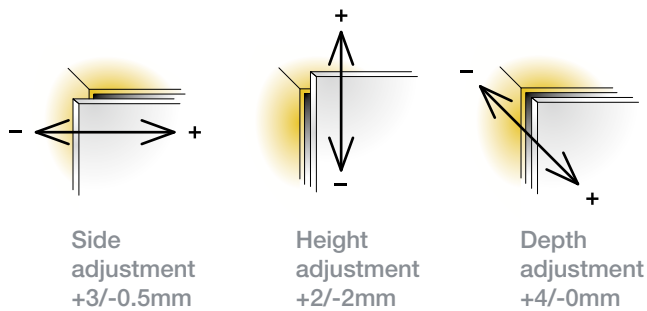

For further explanation → see pages 2.22-2.24

Mounting details

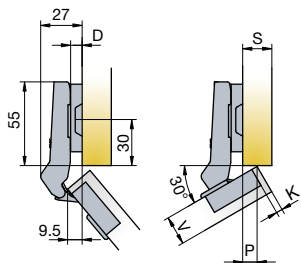

Mounting plate drilling distance

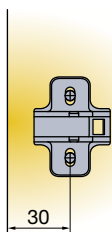

Mounting plate thickness table

For further explanation → see page 2.13

P	2.5	3.5	4.5	8.5	9.5	10.5	11.5	12.5	13.5
3	9			3	2	1	0		
K 4		9			3	2	1	0	
5			9			3	2	1	0

D

Drawings show application on D=3mm mounting plate

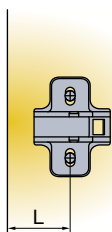
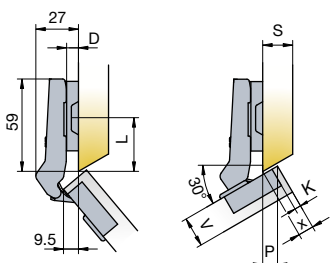

X	2	3	4	9	10	11	12	13	14	15
3	9			3	2			0		
K 4		9			3	2			0	
5			9			3	2			0

D

Drawings show application on D=3mm mounting plate

L=37 for thickness D=0
 L=36 for thickness D=1
 L=35 for thickness D=2
 L=34 for thickness D=3
 L=31 for thickness D=9

Soft closing systems



Glissando TL3
 → see page 2.189

Touch opening



PushOpen Solutions
 → see pages 2.199-2.204

Door clearance

For further explanation → see page 2.14

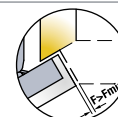

V	16	17	18	19	20	21	22
3	0.3	0.5	0.7	1.0	1.3	1.7	2.5
K 4	0.3	0.5	0.7	0.9	1.2	1.6	2.1
5	0.3	0.5	0.7	0.9	1.2	1.5	2.0

F_{MIN}

Gap Z_{MIN}=0

B-type 110/45°

45° angled application for wood doors

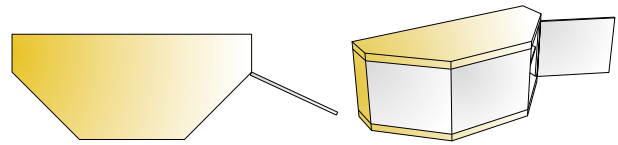
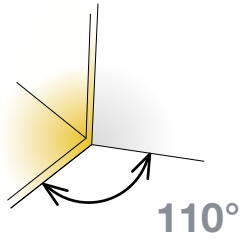

- Opening angle 110°
- Drilling diameter for hinge cup 35mm
- Drilling depth 11.5mm
- Hinge on plate mounting system slide-on



Technical details

Cup type	Interaxis 45mm	Interaxis 48mm
Item number	Item number	Item number
	248-0L32-650	248-0L27-650
	248-0N38-050	248-0L71-050

Drilling patterns for hinge cups → see page 2.17

Cranking
9mm

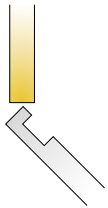

200 Pcs

Cup made of steel, arm made of zinc

Mounting plates



Cruciform mounting plate
→ see page 2.167

Hinge cup screws

If not pre-mounted

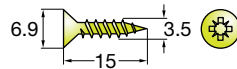

820-6308-050

10000 Pcs

Accessories



Cover caps for hinge arm
→ see page 2.177



Hinge angle restrictor
→ see page 2.175

Legend of hinge cup symbols

Screw-on ready
← screws

Machine insertion ready

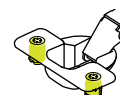

Door adjustment

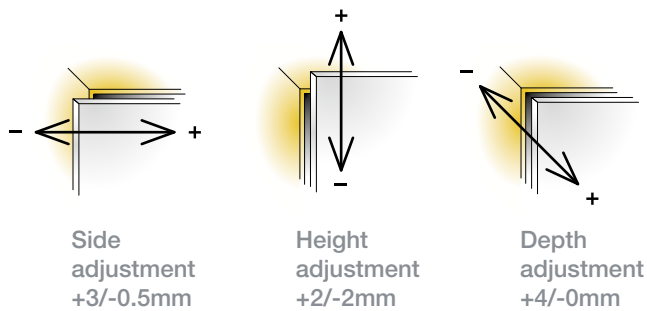

For further explanation → see pages 2.22-2.24

Mounting details

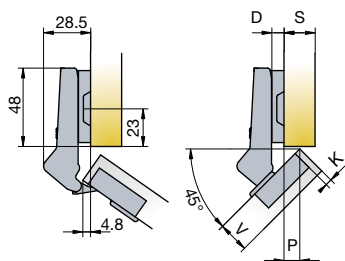

Drawings show application on D=3mm mounting plate

Mounting plate drilling distance

Mounting plate thickness table
For further explanation → see page 2.13

P	9	9.5	10	10.5	11	11.5	12	12.5	13.5
3	3		2		1		0		
K 4		3		2		1		0	
5				3		2		1	0 D

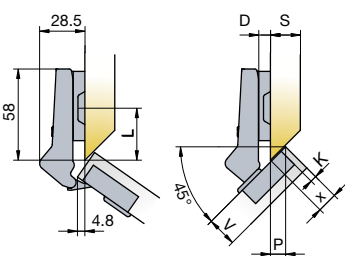

Drawings show application on D=3mm mounting plate

L=36 for thickness D=0
L=35 for thickness D=1
L=34 for thickness D=2
L=33 for thickness D=3

X 11.5 12.5 13 13.5 14 14.5 15 15.5 16 16.5 17 18

3	3		2		1		0					
K 4		3		2		1		0				
5				3		2		1	0	D		

Soft closing systems



Glissando TL3
→ see page 2.189

Touch opening



PushOpen Solutions
→ see pages 2.199-2.204

Door clearance

For further explanation → see page 2.14

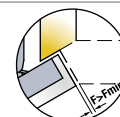

V	16	17	18	19	20	21	22
3	0.3	0.5	0.7	1.0	1.3	1.7	2.5
K 4	0.3	0.5	0.7	0.9	1.2	1.6	2.1
5	0.3	0.5	0.7	0.9	1.2	1.5	2.0 F _{MIN}

Gap Z_{MIN}=0

B-type 110/45°

45° angled application for wood doors

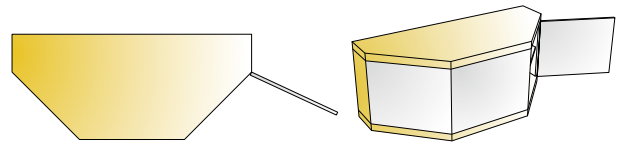
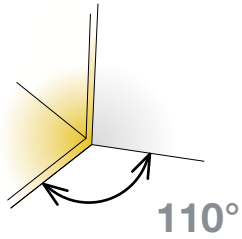

- Opening angle 110°
- Drilling diameter for hinge cup 35mm
- Drilling depth 11.5mm
- Hinge on plate mounting system slide-on



Technical details

Cup type	Interaxis 45mm	Interaxis 48mm
Item number	Item number	Item number
	248-0L33-050	248-0L28-050
	248-0L46-050	248-0L70-050

Drilling patterns for hinge cups → see page 2.17

Cranking
18mm

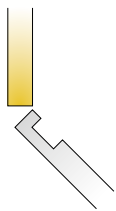

200 Pcs

Cup made of steel, arm made of zinc

Mounting plates



Cruciform mounting plate
→ see page 2.167

Hinge cup screws

If not pre-mounted

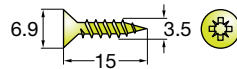

820-6308-050

10000 Pcs

Accessories



Cover caps for hinge arm
→ see page 2.177



Hinge angle restrictor
→ see page 2.175

Legend of hinge cup symbols

Screw-on ready
← screws

Machine insertion ready

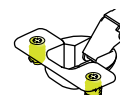

Door adjustment

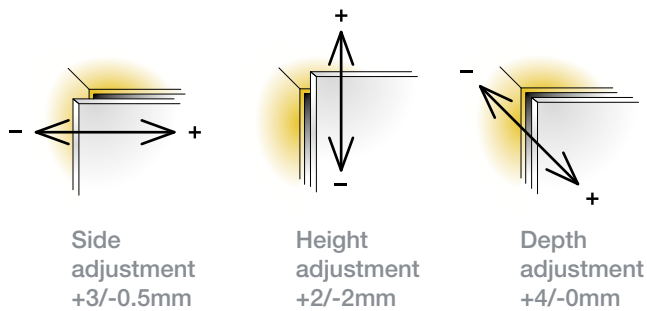

For further explanation → see pages 2.22-2.24

Mounting details

Mounting plate drilling distance

Mounting plate thickness table
For further explanation → see page 2.13

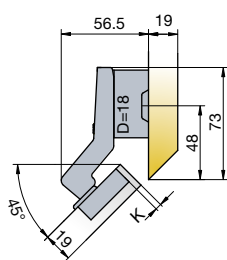

Drawing shows application on D=18mm mounting plate

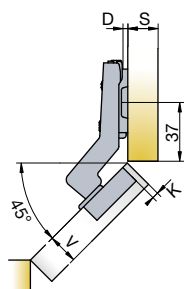

Drawing shows application on D=0mm mounting plate

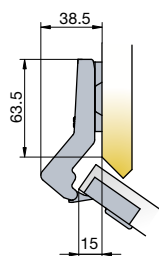
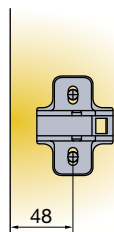

Drawings show application on D=3mm mounting plate

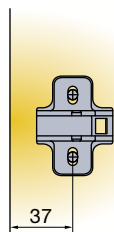
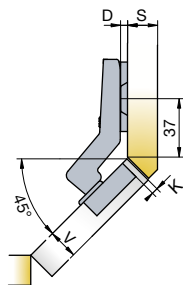

	3	0	
K	4	1	
	5	2	D

Soft closing systems



Glissando TL3
→ see page 2.189

Touch opening



PushOpen Solutions
→ see pages 2.199-2.204

Door clearance

For further explanation → see page 2.14

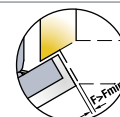

V	16	17	18	19	20	21	22	
3	0.3	0.5	0.7	1.0	1.3	1.7	2.5	
K	4	0.3	0.5	0.7	0.9	1.2	1.6	2.1
5	0.3	0.5	0.7	0.9	1.2	1.5	2.0	F _{MIN}

Gap Z_{MIN}=0

B-type 110/90°

For wood door cabinets with blind panels

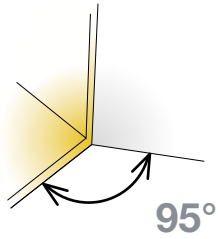
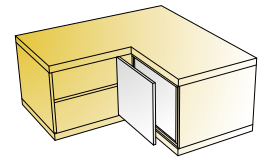

- Opening angle 95°
- Drilling diameter for hinge cup 35mm
- Drilling depth 11.5mm
- Hinge on plate mounting system slide-on



Technical details

	Interaxis 45mm	Interaxis 48mm
Cup type		
Item number	248-0G58-050	248-0G53-050
Item number	248-0G83-050	248-0L73-050

Cranking
18mm

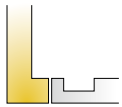

200 Pcs Cup made of steel, arm made of zinc

Cranking
0mm

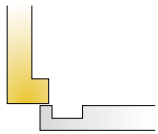

200 Pcs Cup made of steel, arm made of zinc

Blind panel
mounting plate



200 Pcs Made of zinc

	248-0G58-050	248-0G53-050
	248-0G83-050	248-0L73-050

Drilling patterns for hinge cups → see page 2.17

	248-0255-050	248-0V66-050
--	--------------	--------------

Drilling patterns for hinge cups → see page 2.17



Opening angle 110°

	244-0810-650	
	11 244-0813-650	
	13 244-0C32-650	
	15 244-0P28-650	

This mounting plate can be only used with B-type 110/90° hinges. Information about mounting plate symbols → see page 2.168

Mounting plates



These hinges can only be used with blind panel mounting plates

Hinge cup screws
If not pre-mounted

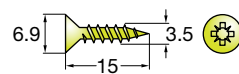

820-6308-050

10000 Pcs

Accessories



Cover caps for hinge arm
→ see page 2.177



Hinge angle restrictor
→ see page 2.175

Legend of hinge cup symbols

Screw-on ready
← screws

Machine insertion ready

Pre-mounted euro screws

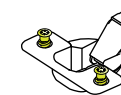
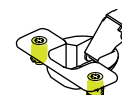

Door adjustment

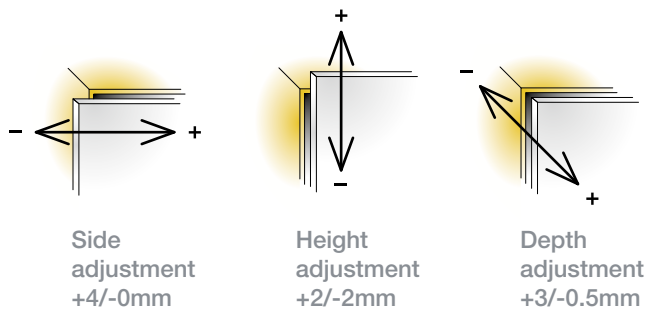

For further explanation → see pages 2.22-2.24

Mounting details

Mounting plate drilling distance

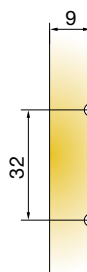
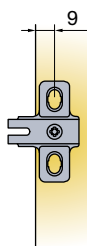
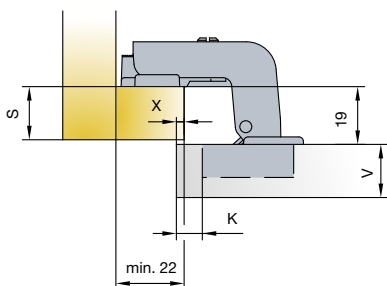
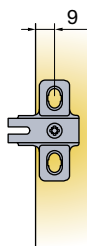
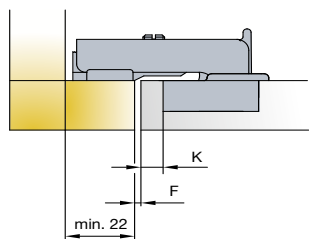

Soft closing systems

Touch opening

Door clearance

For further explanation → see page 2.14

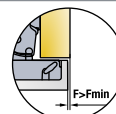

Glissando TL3
→ see page 2.189



PushOpen Solutions
→ see pages 2.199-2.204

V	16	17	18	19	20	21	22	
3	0.3	0.5	0.7	1.0	1.3	1.7	2.5	
K	4	0.3	0.5	0.7	0.9	1.2	1.6	2.1
5	0.3	0.5	0.7	0.9	1.2	1.5	2.0	F _{MIN}

Gap Z_{MIN}=0

B-type 110 AL

For aluminium frame doors

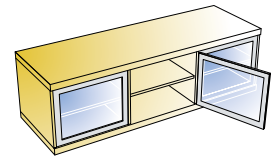
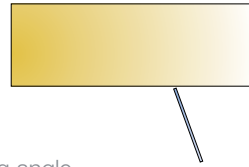
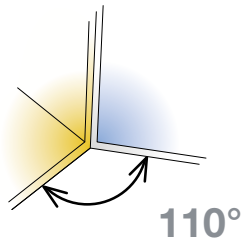

- Opening angle
- Drilling diameter for hinge cup
- Drilling depth
- Hinge on plate mounting system

110°
35mm
11.5mm
slide-on

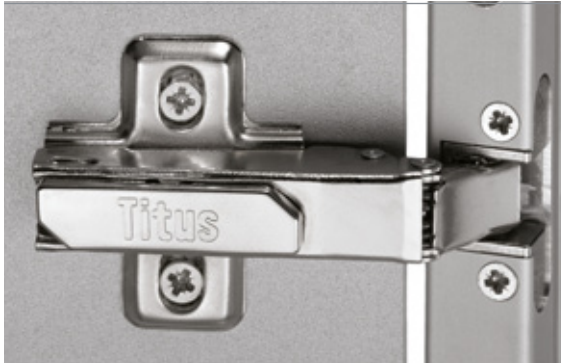

Technical details

Interaxis
28mm

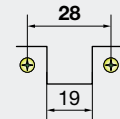

Cup type

Item number

Cranking
0mm



200 Pcs

Cup made of zinc, arm made of steel



950-0T26-050

* Fixing screws included

Cranking
9mm



200 Pcs

Cup made of zinc, arm made of steel



950-0T49-050

* Fixing screws included

Cranking
15mm

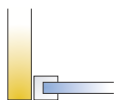

200 Pcs

Cup made of zinc, arm made of steel



950-0T51-050

* Fixing screws included

Mounting plates



Cruciform mounting plate
→ see page 2.167

Hinge cup screws

If not pre-mounted

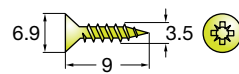

820-6350-050

10000 Pcs

Legend of hinge cup symbols



Screw-on ready
← screws

Accessories



Cover caps for hinge arm
→ see page 2.177



Hinge angle restrictor
→ see page 2.175



Opening angle
Hinge on plate mounting system

110°
SLIDE-ON

Door adjustment

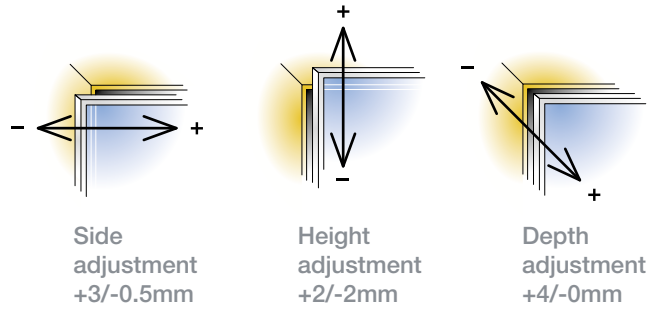

For further explanation → see pages 2.22-2.24

Mounting details

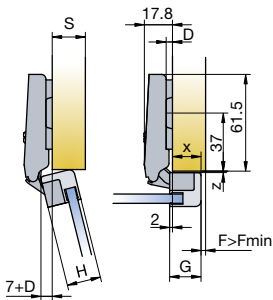

Mounting plate drilling distance

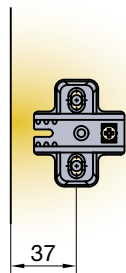

Mounting plate thickness table

For further explanation → see page 2.13

X	12	13	14	15	16	17	18		
17	3	2	1	0					
18	4	3	2	1	0				
G	19	5	4	3	2	1	0		
	20	6	5	4	3	2	1	0	D

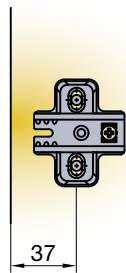
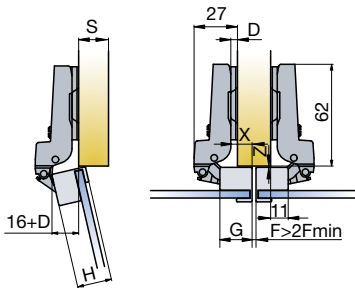

X	3	4	5	6	7	8	9		
17	3	2	1	0					
18	4	3	2	1	0				
G	19	5	4	3	2	1	0		
	20	6	5	4	3	2	1	0	D

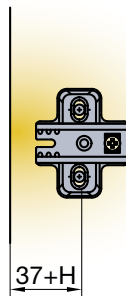
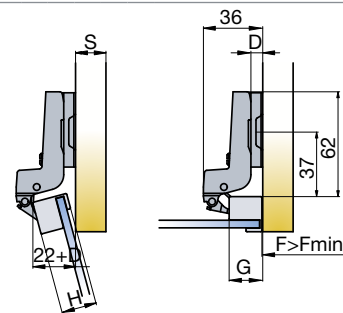

H	17	18	19	20	21	22	
17	1	1	2	2	2	3	
18	2	2	3	3	3	3	
G	19	3	3	3	3		
	20	2	2				D

Drilling pattern for aluminium frame hinges

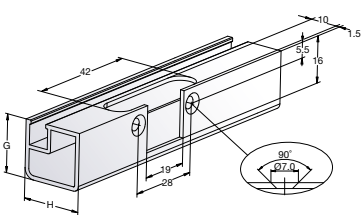

Mounting details

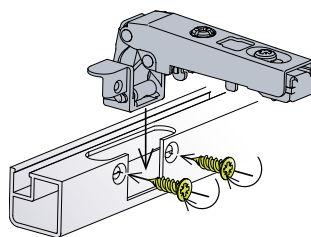

Screws included

Door clearance

For further explanation → see page 2.14

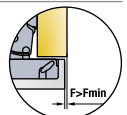

H	17	18	19	20	21	22		
17	0.5	0.7	1.1	1.4	1.8	2.9		
18	0.5	0.7	1.0	1.3	1.7	2.5		
G	19	0.5	0.7	0.9	1.2	1.6	2.1	
	20	0.5	0.7	0.9	1.2	1.5	2.0	F _{MIN}

Gap Z_{MIN}=0.5

B-type 110 AL

For aluminium frame doors
Glissando AL soft closing ready

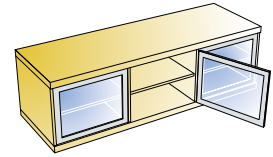
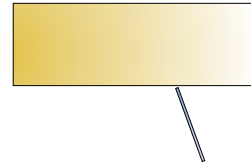
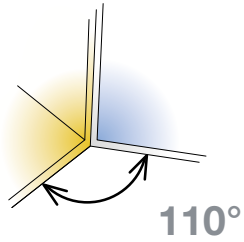

- Opening angle
- Drilling diameter for hinge cup
- Drilling depth
- Hinge on plate mounting system

110°
35mm
11.5mm
slide-on



Interaxis
28mm

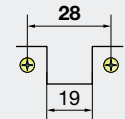

Cup type

Item number

Cranking
0mm

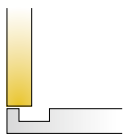

200 Pcs

Made of steel



950-0464-050

* Fixing screws included

Cranking
9mm

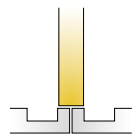

200 Pcs

Made of steel



950-0465-050

* Fixing screws included

Cranking
15mm

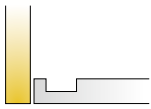

200 Pcs

Made of steel



950-0466-050

* Fixing screws included

Mounting plates



Cruciform mounting plate
→ see page 2.167

Hinge cup screws If not pre-mounted

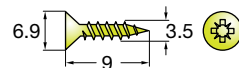

820-6350-050

10000 Pcs

Legend of hinge cup symbols



Screw-on ready
← screws

Accessories



Cover caps for hinge arm
→ see page 2.177



Hinge angle restrictor
→ see page 2.175



· Hinge for aluminium frame door which can be used with Glissando AL for soft closing solution

Door adjustment

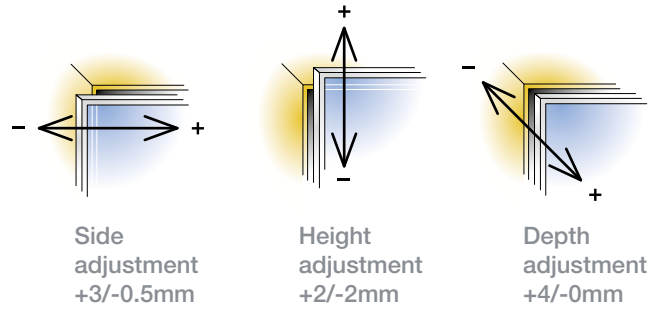

For further explanation → see pages 2.22-2.24

Mounting details

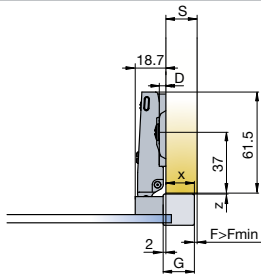
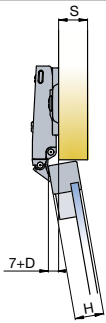

Mounting plate drilling distance

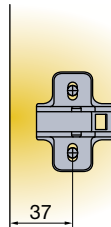

Mounting plate thickness table

For further explanation → see page 2.13

X	12	13	14	15	16	17	18		
17	3	2	1	0					
18	4	3	2	1	0				
G	19	5	4	3	2	1	0		
	20	6	5	4	3	2	1	0	D

$D=13+K-X$

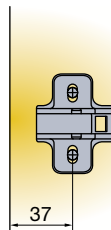
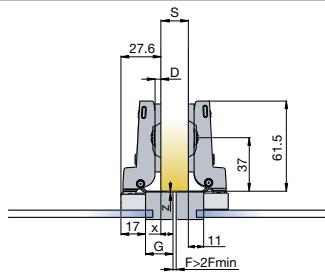
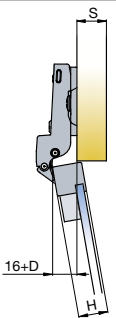

X	3	4	5	6	7	8	9		
17	3	2	1	0					
18	4	3	2	1	0				
G	19	5	4	3	2	1	0		
	20	6	5	4	3	2	1	0	D

$D=4+K-X$

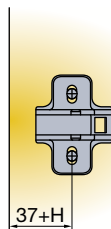
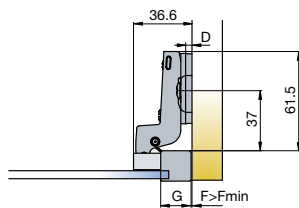
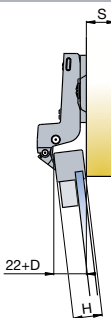

X	17	18	19	20	21	22	
17	1	1	2	2	3	3	
18	2	2	3	3	3	3	
G	19	3	3	3			
	20	3	3				D

$D=-2+K+F$

Soft closing systems



Glissando AL
→ see page 2.193

Door clearance

For further explanation → see page 2.14

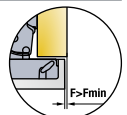

H	17	18	19	20	21	22		
17	0.5	0.7	1.1	1.4	1.8	2.9		
18	0.5	0.7	1.0	1.3	1.7	2.5		
G	19	0.5	0.7	0.9	1.2	1.6	2.1	
	20	0.5	0.7	0.9	1.2	1.5	2.0	F _{MIN}

Gap Z_{MIN}=0.5

B-type 170

For wood doors

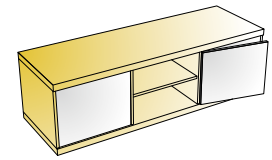
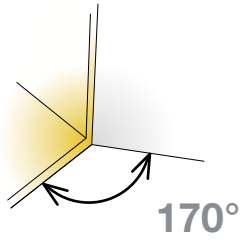

- Opening angle
- Drilling diameter for hinge cup
- Drilling depth
- Hinge on plate mounting system

170°
35mm
12mm
slide-on

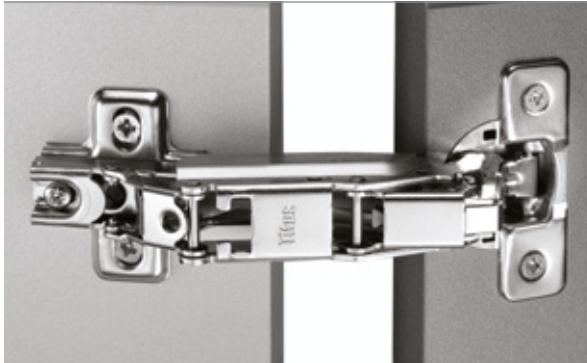

Cup type	Interaxis 45mm	Interaxis 48mm
Item number	Item number	Item number
	248-0R10-050	248-0P43-050
	248-0L51-050	248-0R12-050

Drilling patterns for hinge cups → see page 2.17

Cranking
0mm

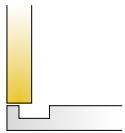

50 Pcs

Made of steel and zinc

Mounting plates



Cruciform mounting plate
→ see page 2.167

Hinge cup screws

If not pre-mounted

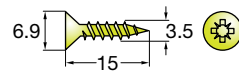

820-6308-050

10000 Pcs

Accessories



Hinge angle restrictor
→ see page 2.175

Legend of hinge cup symbols

Screw-on ready
← screws

Machine insertion ready

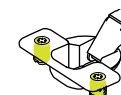

Door adjustment

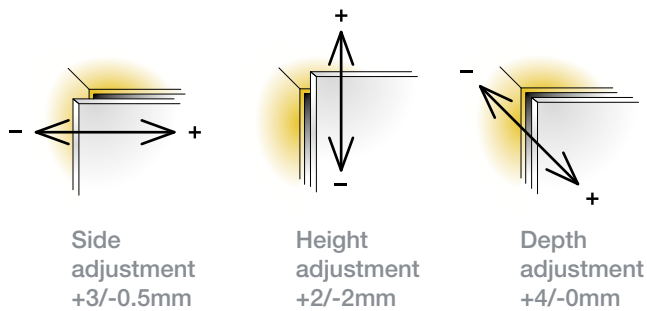

For further explanation → see pages 2.22-2.24

Mounting details

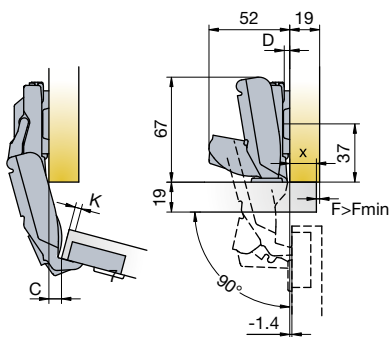

Drawings show application on D=0mm mounting plate

Mounting plate drilling distance

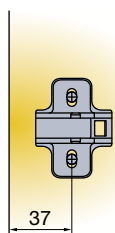

Mounting plate thickness table

For further explanation → see page 2.13

X	10	11	12	13	14	15	16	17	18	19	20
3	6	5	4	3	2	1	0				
4		6	5	4	3	2	1	0			
K 5			6	5	4	3	2	1	0		
6				6	5	4	3	2	1	0	
7					6	5	4	3	2	1	0

$D=13+K-X$

C value with D=0 mounting plates

K	3	4	5	6	7	
C	-9.0	-8.1	-7.1	-6.1	-5.2	D

Soft closing systems



Touch opening

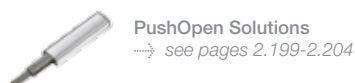

Door clearance

For further explanation → see page 2.14

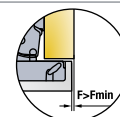

V	16	17	18	19	20	21	22	23	24
3	0.0	0.0	0.0	0.0	0.0	0.0	0.0	0.0	0.0
4	0.0	0.0	0.0	0.0	0.0	0.0	0.0	0.0	0.0
K 5	0.0	0.0	0.0	0.0	0.0	0.0	0.0	0.0	0.0
6	0.0	0.0	0.0	0.0	0.0	0.0	0.0	0.0	2.6
7	0.0	0.0	0.0	0.0	0.0	0.0	0.0	0.0	5.1 F _{MIN}

Gap Z_{MIN}=0

B-type 170

For wood doors

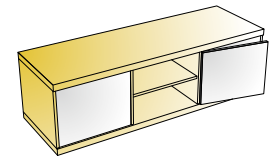
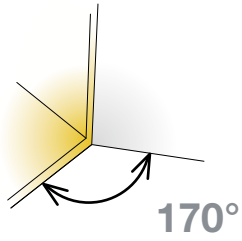

- Opening angle
- Drilling diameter for hinge cup
- Drilling depth
- Hinge on plate mounting system

170°
35mm
12mm
slide-on

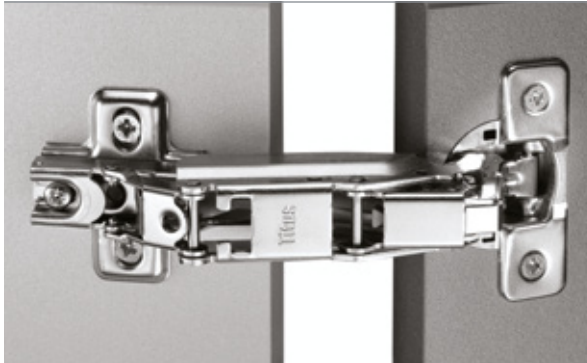

	Interaxis 45mm	Interaxis 48mm
Cup type		
Item number	248-0160-050	248-0161-050

Drilling patterns for hinge cups → see page 2.17

Cranking
9mm

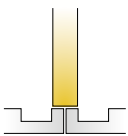

50 Pcs

Made of steel and zinc

Mounting plates



Cruciform mounting plate
→ see page 2.167

Hinge cup screws

If not pre-mounted

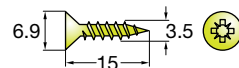

820-6308-050

10000 Pcs

Accessories



Hinge angle restrictor
→ see page 2.175

Legend of hinge cup symbols



Screw-on ready
← screws



Door adjustment

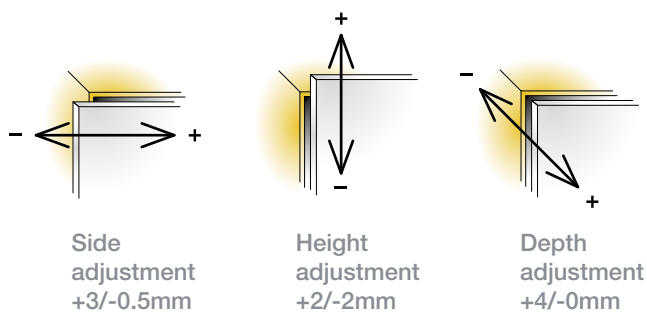

For further explanation → see pages 2.22-2.24

Mounting details

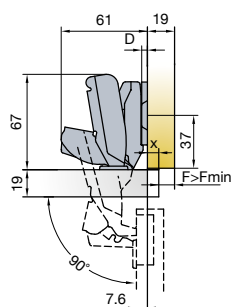
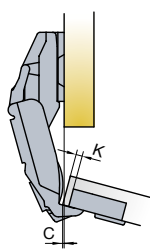

Mounting plate drilling distance

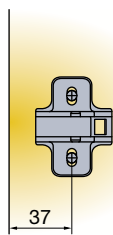

Mounting plate thickness table

For further explanation → see page 2.13

X	1	2	3	4	5	6	7	8	9	10	11
3	6	5	4	3	2	1	0				
4		6	5	4	3	2	1	0			
K 5			6	5	4	3	2	1	0		
6				6	5	4	3	2	1	0	
7					6	5	4	3	2	1	0

$D=4+K-X$

C value with D=0 mounting plates

K	3	4	5	6	7
C	0	0.9	1.9	2.9	3.8

Drawings show application on D=0mm mounting plate

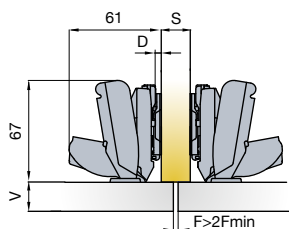

Drawing shows application on D=0mm mounting plate

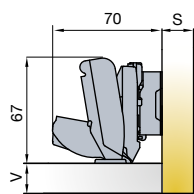

Drawing shows application on D=9mm mounting plate

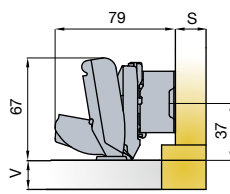

Drawing shows application on D=18mm mounting plate

Soft closing systems



Glissando TL 170
→ see page 2.191



Glissando CR
→ see page 2.195

Touch opening



PushOpen Solutions
→ see pages 2.199-2.204

Door clearance

For further explanation → see page 2.14

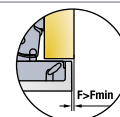

V	16	17	18	19	20	21	22	23	24
3	0.0	0.0	0.0	0.0	0.0	0.0	0.0	0.0	0.0
4	0.0	0.0	0.0	0.0	0.0	0.0	0.0	0.0	0.0
K 5	0.0	0.0	0.0	0.0	0.0	0.0	0.0	0.0	0.0
6	0.0	0.0	0.0	0.0	0.0	0.0	0.0	0.0	2.6
7	0.0	0.0	0.0	0.0	0.0	0.0	0.0	0.0	5.1 F _{MIN}

Gap Z_{MIN}=0

B-type for Pie-cut Corner Cabinet

For wood doors

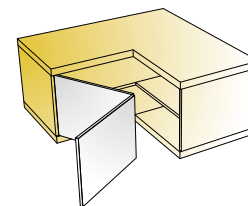

- Drilling diameter for hinge cup 35mm
- Drilling depth 11.5mm
- Hinge on plate mounting system slide-on



Corner cabinet

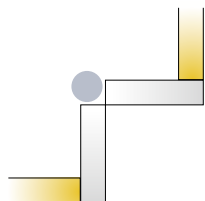

Cup type	Interaxis 45mm	Interaxis 48mm
	Item number	Item number
	248-0T81-050	248-0T80-050
	248-0U13-050	248-0U14-050

Drilling patterns for hinge cups → see page 2.17

100 Pcs

Cup made of steel, arm made of zinc

Mounting plates



Cruciform mounting plate
→ see page 2.167

Hinge cup screws If not pre-mounted

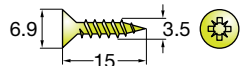

820-6308-050

10000 Pcs

Accessories



Cover caps for hinge arm
→ see page 2.177

Legend of hinge cup symbols

Screw-on ready
← screws

Machine insertion ready

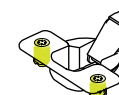

Door adjustment

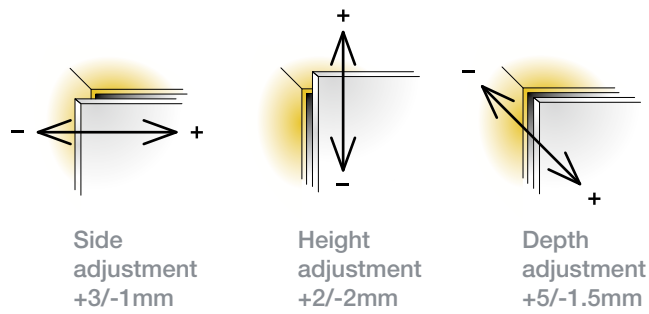

For further explanation → see pages 2.22-2.24

Mounting details

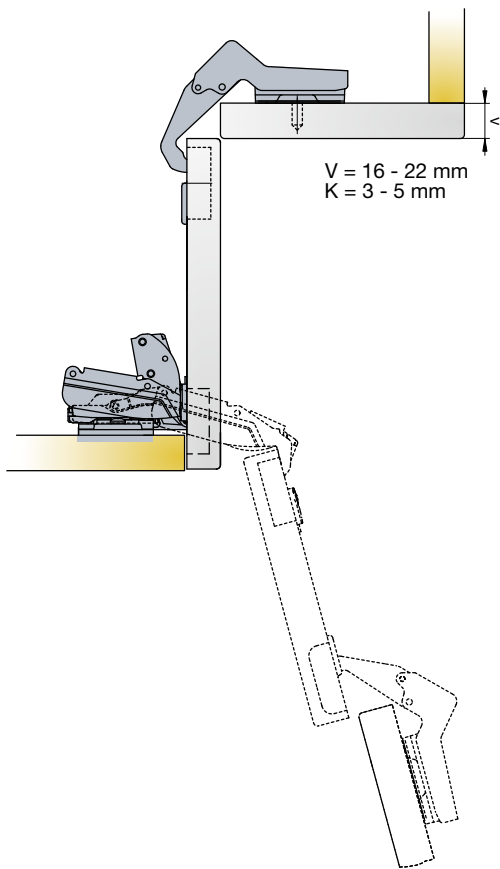

Mounting plate drilling distance

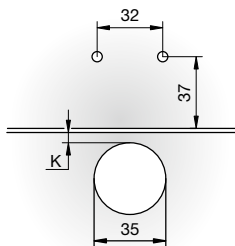

Adjustments

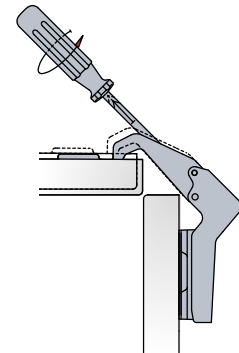

The diagonal adjustment is made by rotating the appropriate screw as shown on the drawing.

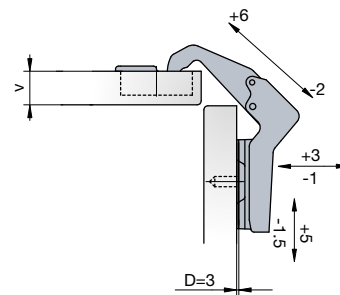

Touch opening



PushOpen Solutions
→ see pages 2.199-2.204

B-type

Flap door hinge

For wood doors

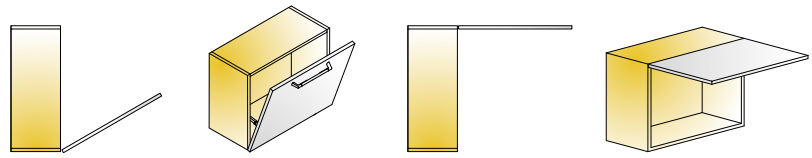

- Opening angle
- Drilling diameter for hinge cup
- Drilling depth
- Hinge on plate mounting system

90°
35mm
11.5mm
slide-on



Interaxis
24mm

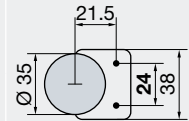

Cup type

Item number

Cranking
0mm

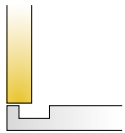

left



926-0A26-050

right



926-0A27-050

* For application it is mandatory to order left and right hinge

200 Pcs

Cup made of steel

Mounting plates



Cruciform mounting plate
→ see page 2.167

Hinge cup screws
If not pre-mounted

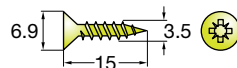

820-6308-050

10000 Pcs

Legend of hinge cup symbols



Screw-on ready
← screws

Accessories



Cover caps for hinge arm
→ see page 2.177





Use with flap stay mechanisms

Door adjustment

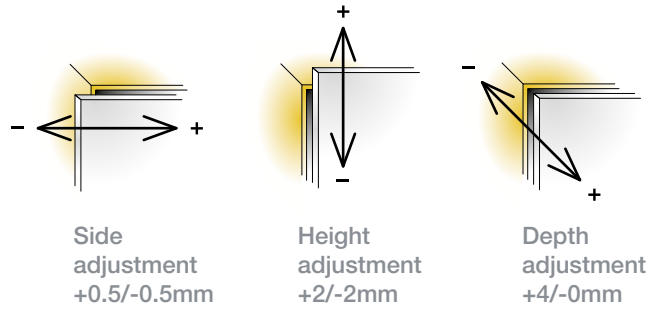

For further explanation → see pages 2.22-2.24

Mounting details

Mounting plate thickness table

For further explanation → see page 2.13

D	0	1	2	3
B (mm)	20	21	22	23

D=mounting plate height
 $X = 22.5 + K - A$

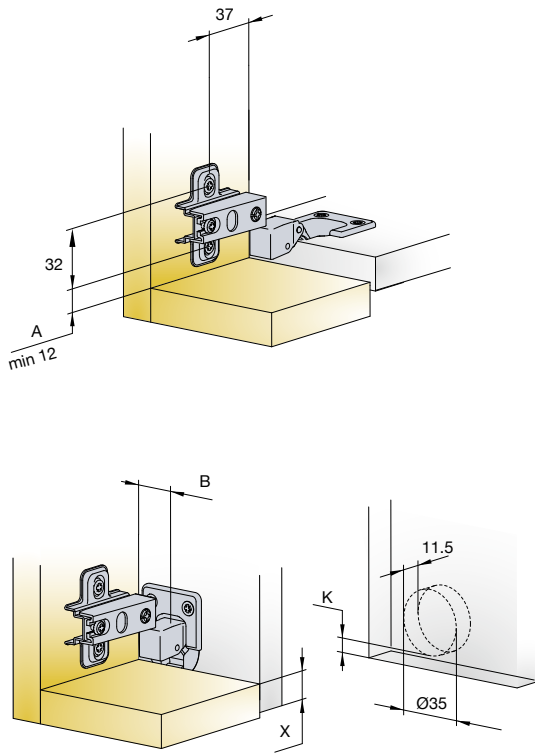

B = distance between two holes center for fixing screws on the hinge cup

Touch opening



PushOpen Solutions
 → see pages 2.199-2.204

Door clearance

For further explanation → see page 2.14

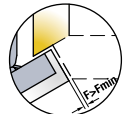

V	16	17	18	19	20	21	22
3	0.3	0.5	0.7	1.0	1.3	1.7	2.5
K	0.3	0.5	0.7	0.9	1.2	1.6	2.1
5	0.3	0.5	0.7	0.9	1.2	1.5	2.0

Gap Z_{MIN}=0

B-type Mounting Plates

B-type slide-on mounting

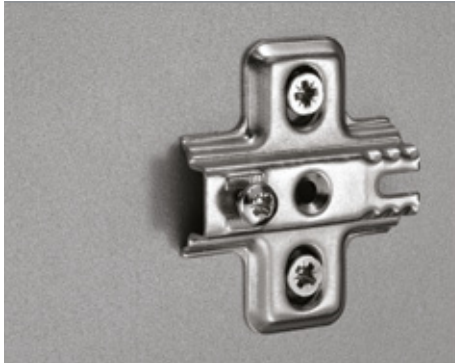
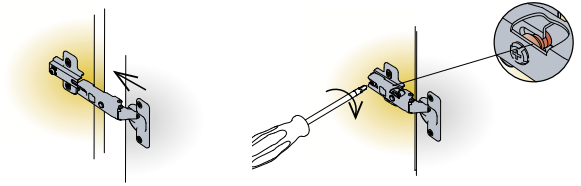

Cruciform mounting plate

Drilling pattern

Dimensions

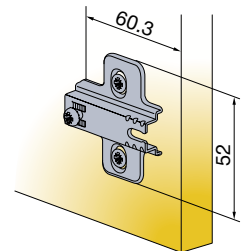
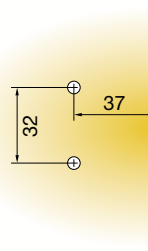

200 Pcs Made of steel

Zinc diecast cruciform mounting plate

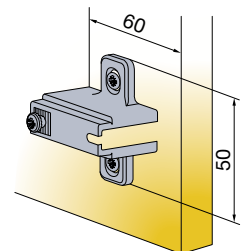
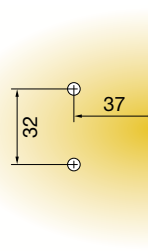

200 Pcs Made of zinc

Fixing screws for mounting plates
If not pre-mounted

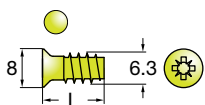

Euro screws
821-6304-050 L=11
821-6323-050 L=13
821-6332-050 L=15

10000 Pcs

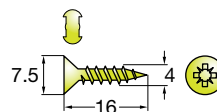

Chipboard screws
820-6328-050

10000 Pcs

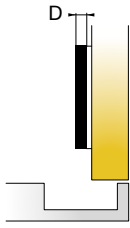

Mounting plate thickness

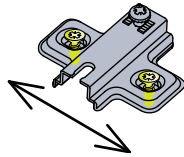

Height adjustment +/- 2mm

Mounting plate type								
Mounting plate thickness (D)								
Item number								
0mm	244-0866-050	*244-0L29-050	244-0965-050	244-0929-050	*244-0L26-050	*244-0L50-050	244-0H64-050	244-0P24-050
1mm	244-0T40-050		244-0K95-050		*244-0S65-050		244-0S67-050	
2mm	244-0T28-050		244-0K96-050		*244-0S66-050	*244-0V64-050	244-0S68-050	
3mm	244-0867-050	*244-0L39-050	244-0G19-050	244-0930-050	*244-0L98-050	*244-0L40-050	244-0H65-050	244-0P25-050
* Available upon special request → see page 0.3								
4mm	244-0L37-650		244-0K97-650				244-0M28-650	
5mm	244-0L38-650		244-0K98-650	244-0T14-650			244-0M29-650	
6mm	244-0232-650		244-0914-650			*244-0B12-650		
9mm	244-0062-650		244-0067-650	244-0P41-650				
18mm	244-0063-650		244-0068-650	244-0175-650				
* Available upon special request → see page 0.3								

Legend of mounting plate type symbols

Screw-on ready for euro screws ← screws	Screw-on ready for chipboard ← screws	Pre-mounted 13mm euro screws	Pre-mounted 15mm euro screws	Pre-mounted chipboard screws	Machine insertion ready	Pre-mounted 7.5mm expanding dowels	Pre-mounted 10.5mm expanding dowels

B-type Mounting Plates

B-type slide-on mounting

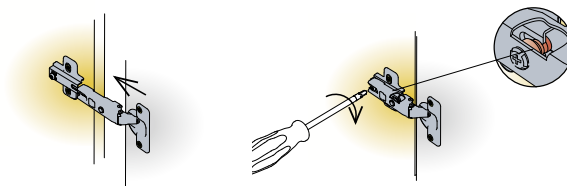

Drilling pattern

Dimensions

Cruciform mounting plate

· Back-to-back application

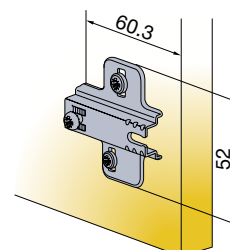
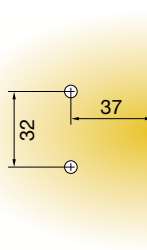

 200 Pcs Made of steel

Zinc diecast cruciform mounting plate

· For 18mm inset doors

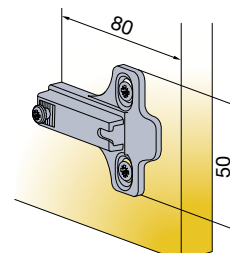
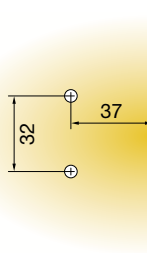

 200 Pcs Made of zinc

Fixing screws for mounting plates

If not pre-mounted

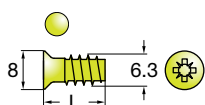

Euro screws
821-6304-050 L=11
821-6323-050 L=13
821-6332-050 L=15

 10000 Pcs

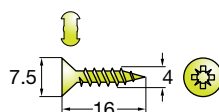

Chipboard screws
820-6328-050

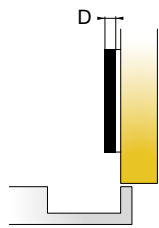

 10000 Pcs



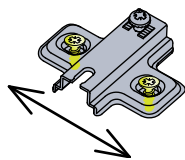

Mounting plate thickness

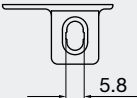
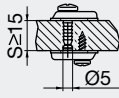
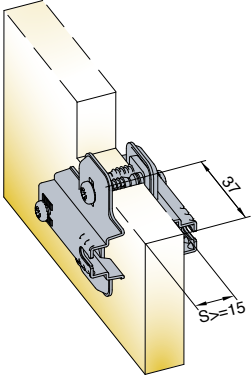
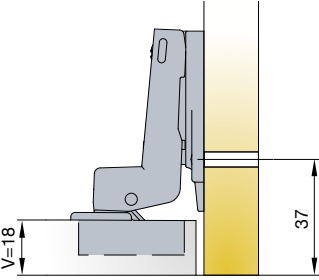

Height adjustment +/- 2mm

	Mounting plate type		
		 10.5	
	 Item number	 Item number	
	3mm		244-0V50-050
 Minimum panel thickness is 15mm			
	2mm	244-0036-650	
 Fits standard 37mm drilling			

Legend of mounting plate type symbols

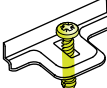
	 10.5
Screw-on ready for euro screws ← screws	Pre-mounted 10.5mm expanding dowels
	

Wide Angle Hinge 270

For wood doors

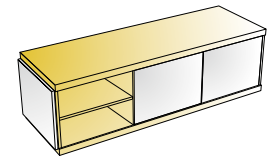
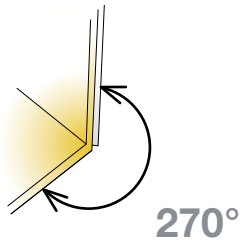

- Opening angle
- Drilling diameter for hinge cup
- Drilling depth
- Hinge on plate mounting system

270°
35mm
12.5mm
key-hole



Wide angle hinge 270



200 Pcs

Made of zinc

Cruciform mounting plate



200 Pcs

Made of zinc

Mounting plates



This hinge can be only used with above cruciform mounting plate

Hinge cup screws
If not pre-mounted

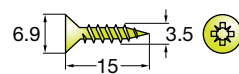

820-6308-050

10000 Pcs

Legend of hinge cup symbols

Screw-on ready
← screws

Machine insertion ready

Pre-mounted euro screws

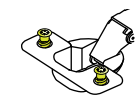
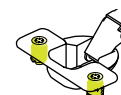

Technical details

Cup type

With spring

Item number



241-0043-650



241-0050-650

D=0mm



244-0907-650



13

244-0848-650

D=2mm



244-0D99-650



13

244-0E02-650

D=6mm



244-0D47-650



13

244-0D46-650

This mounting plate can be only used with Wide angle hinge 270. Information about mounting plate symbols → see page 2.168

Door adjustment

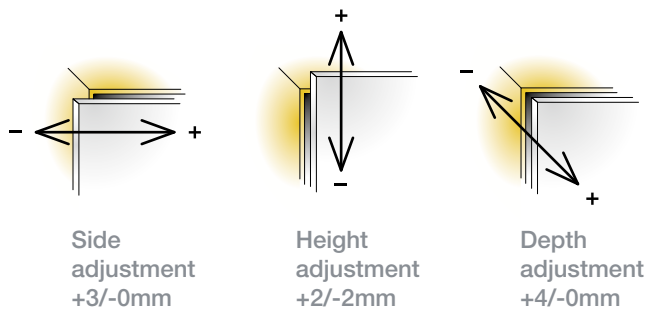

For further explanation → see pages 2.22-2.24

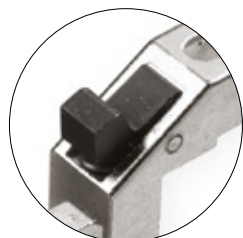

With spring

Mounting details

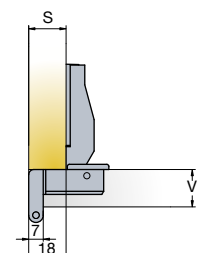

Drawing shows application on D=0 mounting plate and S=18 side panel.

Mounting plate drilling distance

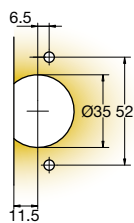
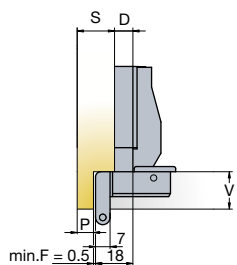

Drawing shows application on D=6mm mounting plate

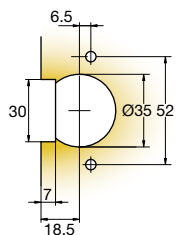

Mounting plate drilling distance

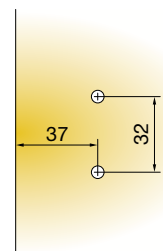

Mounting plate thickness table

For further explanation → see page 2.13

S	16	17	18	19	20	21	22	23	24
0	2		0						
1		2		0					
2			2		0				
3				2		0			
4	6				2		0		
5		6				2		0	
P 6			6				2		0
7				6				2	
8					6				2
9						6			
10							6		
11								6	
12									6

Door thickness



For correct opening, door thickness has to be (V_{MAX}) 21mm

Refrigerator Cabinet Door Hinge 100

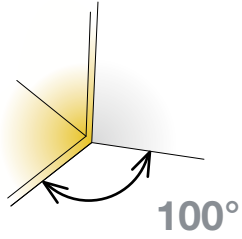

- Opening angle 100°
- Drilling diameter for hinge cup 35mm
- Drilling depth 11mm
- Hinge on plate mounting system key-hole



Technical details

Cup type	Interaxis 45mm	Interaxis 48mm
Item number	248-0R09-050	248-0K10-050
		248-0M41-050

Drilling patterns for hinge cups → see page 2.17

Cranking 0mm

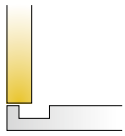

200 Pcs Cup made of steel, arm made of zinc

Cruciform mounting plate



244-0655-050

13 244-0846-050

This mounting plate can be only used with Refrigerator cabinet door hinge 100. Information about mounting plate symbols → see page 2.168

500 Pcs Made of steel

Mounting plates



This hinge can be mounted only with above cruciform mounting plates.

Hinge cup screws
If not pre-mounted

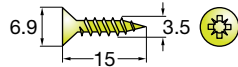

820-6308-050

10000 Pcs

Legend of hinge cup symbols

Screw-on ready
← screws

Machine insertion ready

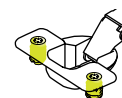

Door adjustment

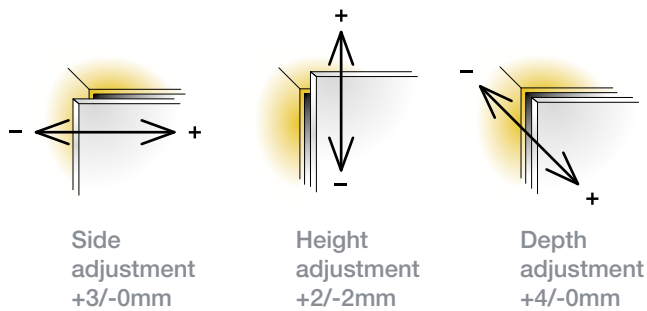

For further explanation → see pages 2.22-2.24

Mounting details

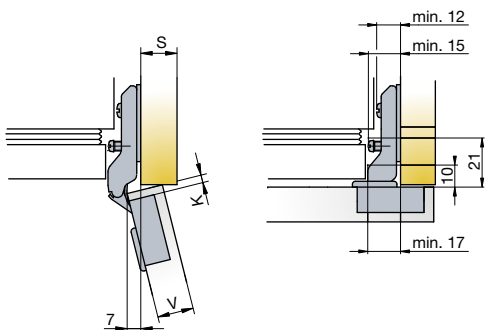

Drawings show application on mounting plate

Mounting plate drilling distance

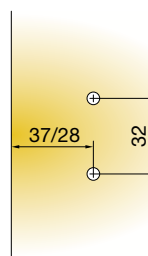
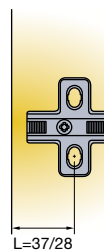

Door clearance

For further explanation → see page 2.14

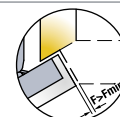

V	16	17	18	19	20	21	22	
3	0.3	0.5	0.7	1.0	1.3	1.7	2.5	
K	4	0.3	0.5	0.7	0.9	1.2	1.6	2.1
5	0.3	0.5	0.7	0.9	1.2	1.5	2.0	F _{MIN}

Gap Z_{MIN}=0

Hinge Angle Restrictors

For all Titus Hinges with 110° and 170° opening angle

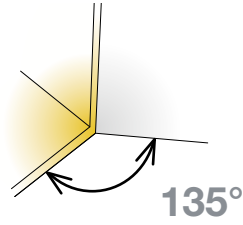
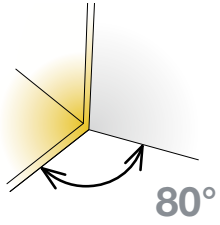

Technical details

Item number

Light grey

80° Hinge Angle Restrictor T-type

For all T-type 110°

728-4669 →

380

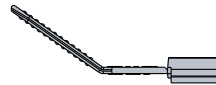
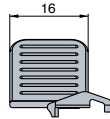

200 Pcs

Made of plastic

80° Hinge Angle Restrictor S-type, B-type

For all S-type 110° and B-type 110°

248-4668 →

380

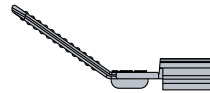
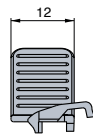

200 Pcs

Made of plastic

135° Hinge Angle Restrictor

For all 170° hinges

248-4672 →

380

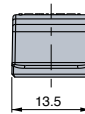

200 Pcs

Made of plastic

- Hinge angle restrictor limits opening angle
- Prevents door damage
- Easy and quick mounting and dismounting

Mounting details

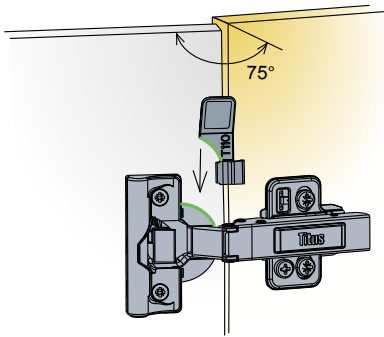

Open the door to approximately 75° and position angle restrictor to follow the hinge cup form

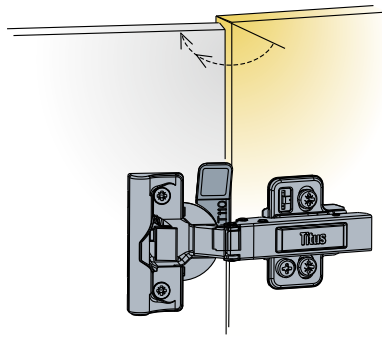

Slightly open the door to hear the click meaning angle restrictor is in the right position

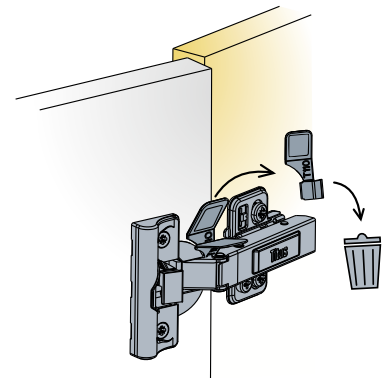

Close the door to remove the restrictor holder (cracks by itself while closing the door)

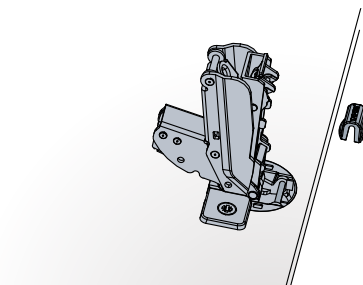

Hinge has to be in closed position

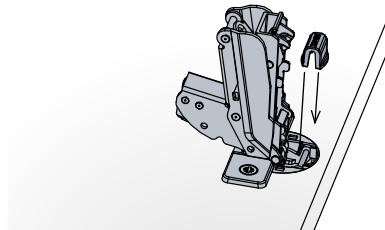

Insert angle restrictor into the hinge cup

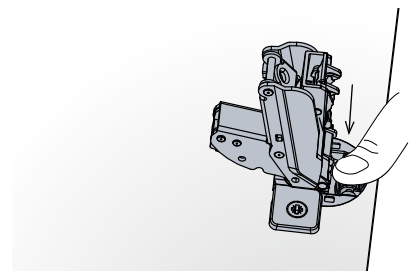







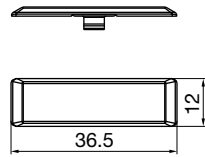

When angle restrictor is in the right position push it down

Recommended to insert angle restrictor while doors are not mounted on the cabinet

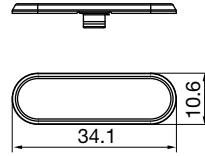
Cover Caps

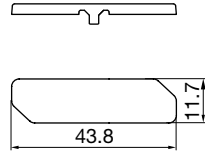
For hinge arms

		Technical details	Plate type	Material/surface	Item number	Nickel plated
T-type  	 5000 Pcs Made of steel	Titus	steel	728-1286 →	054	
		neutral	steel	728-1283 →	054	
Only for T-type 110 0mm, 120 0mm, 110/15°, 110/30°, 110/45° 9mm, 17mm and 23mm, 110/90° 17mm						
T-type  	 5000 Pcs Made of steel	Titus	steel	728-1287 →	054	
		neutral	steel	728-1284 →	054	
For all T-type range						
S-type B-type  	 4000 Pcs Made of steel	Titus	steel	248-1646 →	050	
		neutral	steel	248-1712 →	050	

Glissando Soft Closing Systems for Hinges

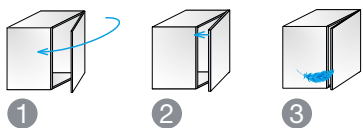

ConfidentClose

- 1 Fast closing
- 2 Late start of deceleration action
- 3 Quiet landing with 'SoftTouch'

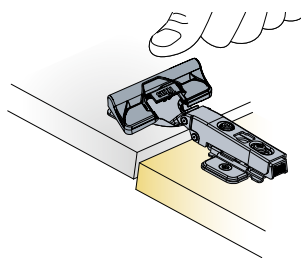

Tool-less mounting

- Reduced assembly time
- Flexible usage also as a retrofit option

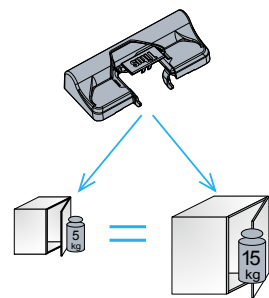

Consistent Performance

- Only one Glissando for two to three hinges
- Allows for consistent performance on a wide range of door dimensions and weights

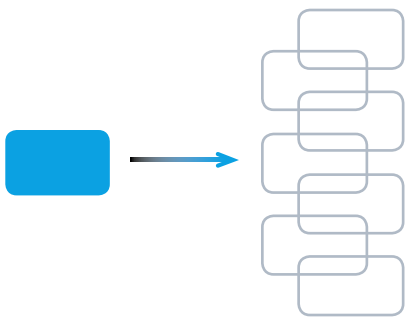

One-for-all

- One item fits multiple applications
- Same item can be used on all crankings and angled hinges



Titus Damper Inside

- Titus proprietary multi-purpose damping technology
- Reliable and consistent damping

Glissando Add-on

Soft Closing Range

How to Choose the Right Glissando?

Glissando TT
 Glissando TL3
 Glissando TL 170
 Glissando CR
 Glissando AL

Titus Glissando soft closing system is available for the whole range of hinge applications. The user can choose between add-on or stand-alone solutions.

Concealed hinges	Add-on hinge soft closing solutions			Stand-alone door soft closing solution	
	Glissando TT	Glissando TL3	Glissando TL 170	Glissando CR	Glissando AL
T-type 95	X			X	X
T-type 110	X			X	X
T-type 110/15°	X				
T-type 110/30°	X				
T-type 110/45°	X				
T-type 110/90°	X				
T-type 120	X			X	X
T-type 170			X	X	X
S-type 110		X		X	X
S-type 110/15°		X			
S-type 110/24°		X			
S-type 110/30°		X			
S-type 110/45°		X			
S-type 110/90°		X			
S-type 170			X	X	X
S-type 110 AL					X
B-type 110		X		X	X
B-type 110/30°		X			
B-type 110/45°		X			
B-type 110/90°		X			
B-type 170			X	X	X
B-type 110 AL					X



Titus Glissando soft closing devices can not be used with unsprung and reverse spring hinges.
→ for details check page 2.24

Glissando TT 'One-for-all'

T-type

- One item fits multiple applications
- Same item can be used on all crankings and angled hinges
- Designed to fit the concealed hinge cup
- Tool-less mounting
- Suitable for different types of cabinets for kitchens, living rooms, bathrooms and other furniture

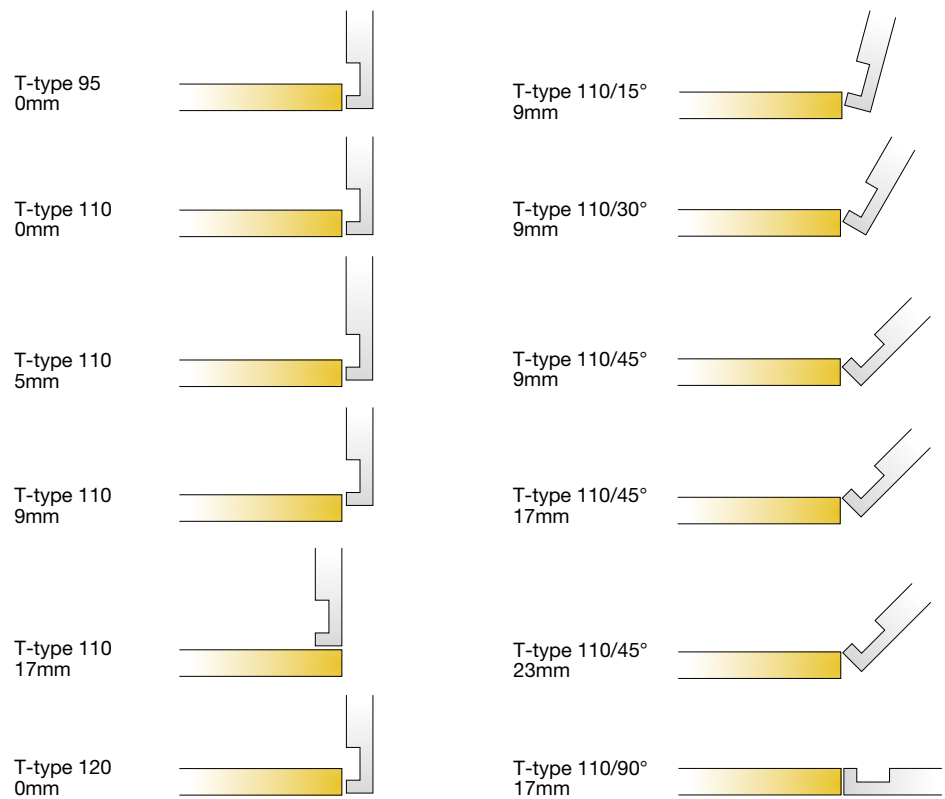
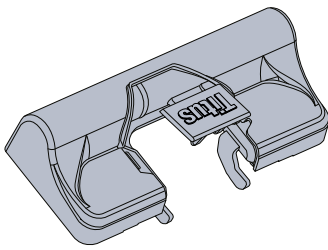

Glissando

Application

Glissando TL3 'One-for-all'

S-type B-type

- One item fits multiple applications
- Same item can be used on all crankings and angled hinges
- Adjustable damping enables perfect functioning on every door
- Designed to fit the concealed hinge cup
- Tool-less mounting
- Suitable for different types of cabinets for kitchens, living rooms, bathrooms and other furniture

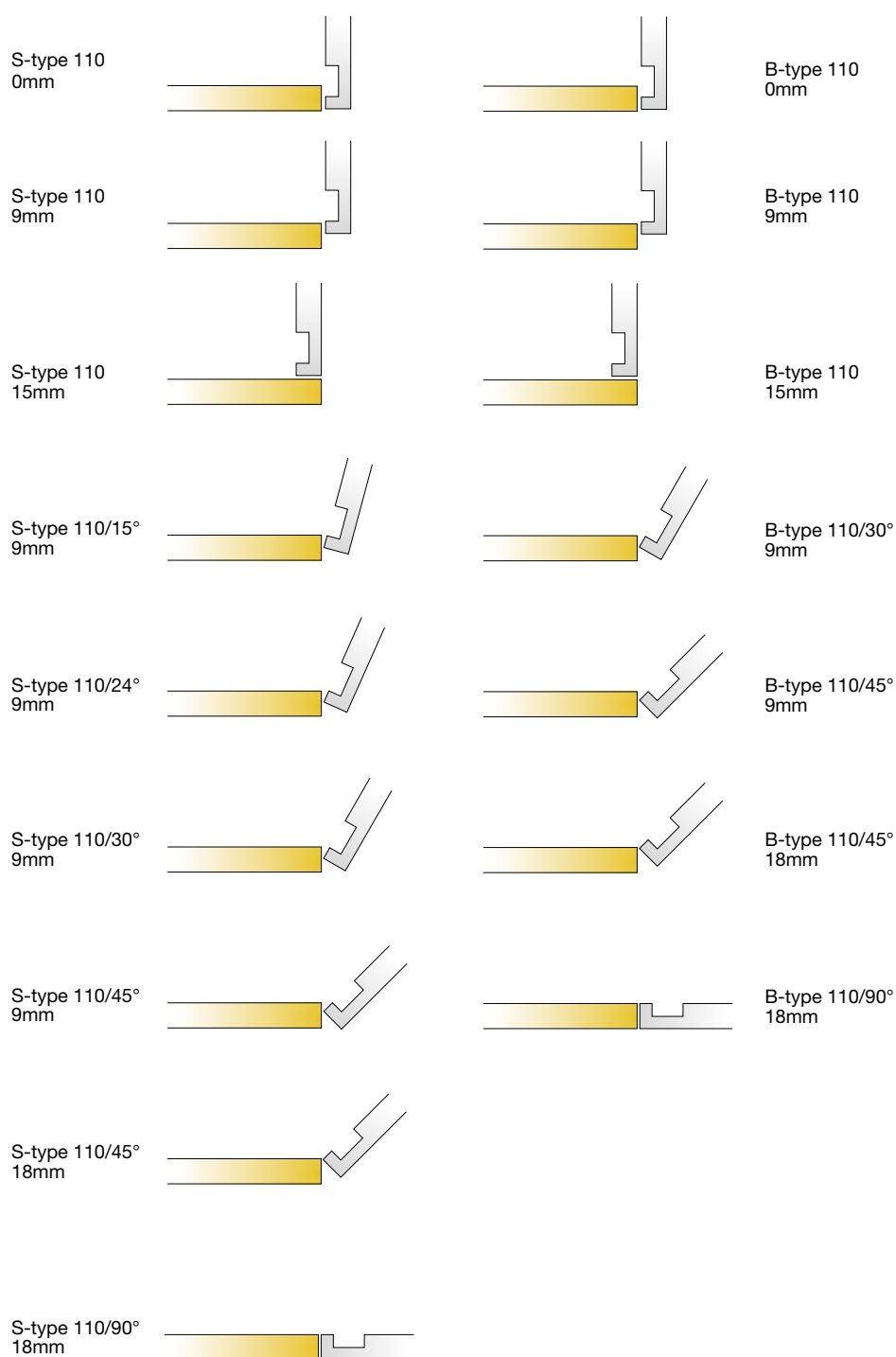
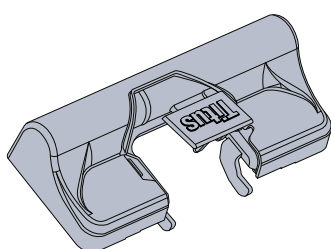

Glissando

Number per Door and Positioning

How Many Glissandos per Door?

Add-on hinge soft closing solution

Glissando TT
Glissando TL3
Glissando TL 170

Number of Glissando per door depends on door dimensions, door weight, hinge arrangement. Trial mounting is recommended.

Glissando TT

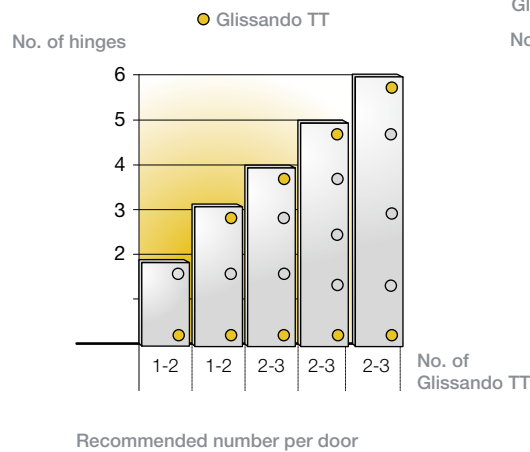

Glissando TL3
Glissando TL170

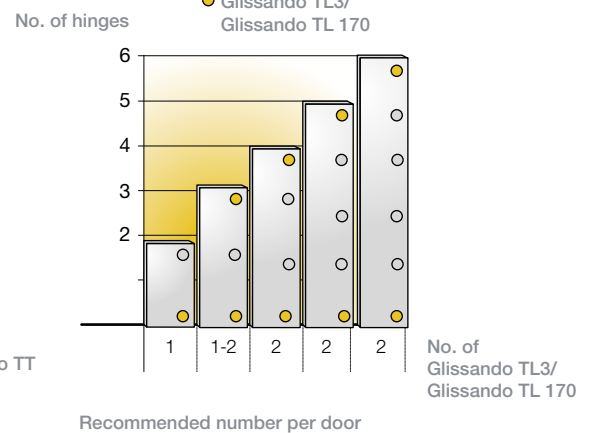

Stand-alone soft closing solution

Glissando CR
Glissando AL

Mount Glissando CR/AL on the hinged side of the cabinet on the top or bottom.

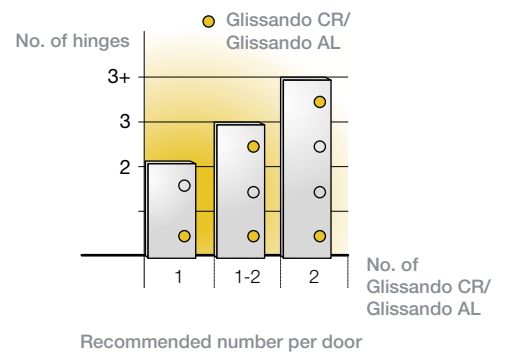

Glissando Mounting

How to Mount Glissando?

Tool-less mounting

Glissando TL3
Glissando TT
Glissando TL 170

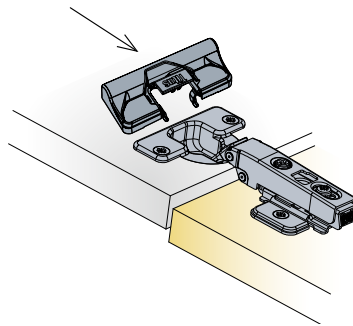

Simple tool-less assembly: Insert Glissando into the holes on the hinge and press down with hand.

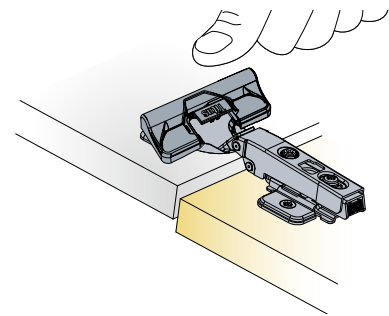

The tool-less 'snap on' version for reduced assembly time and flexibility of application. Glissando TL can be mounted at any time after furniture assembly so can be offered as a retro fit option by the installer.

Screw-on into the cabinet corner

Glissando CR

Glissando CR is mounted into the cabinet corner by using chipboard screws 20mm long.

Glissando dampers' discreet design enhances the look of the door and occupies minimal space in the cabinet interior.

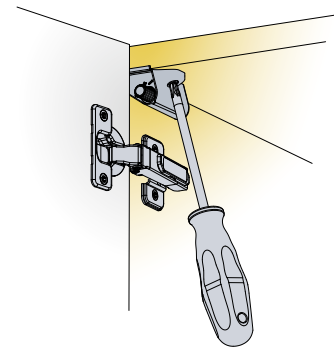

Screw-on onto the mounting plate

Glissando AL

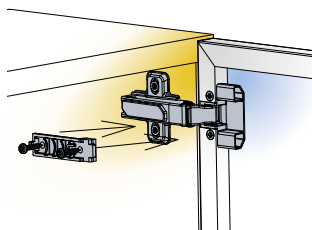

Position the mounting plate below the hinge arm and fix with two screws. Use hinge mounting plate as a reference.

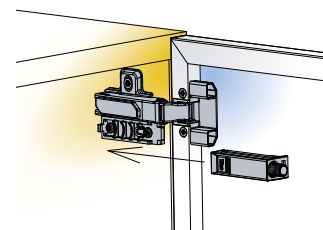

Slide Glissando AL onto the mounting plate

Glissando

Damping Adjustment

How to Adjust Damping?

Add-on hinge soft closing solution

Glissando TL 170

Glissando features quarter turn adjustment to provide optimal closing speed for any door dimensions and weight.

The damping function can be adjusted to fit different door weights which enables

- perfect door functioning
- use of the same type of Glissando for various doors

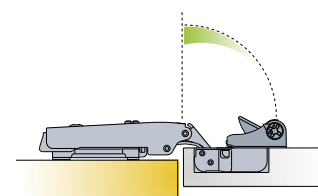

Adjustable damping zone

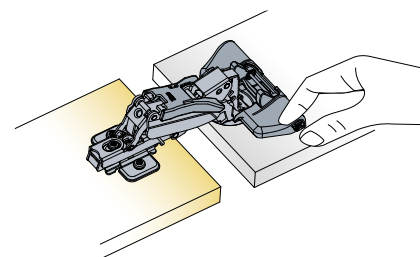

Turn towards '+' to increase and '-' to decrease the damping

Stand-alone soft closing solution

Glissando CR
Glissando AL

Turn towards '+' to increase or towards '-' to decrease the damping.

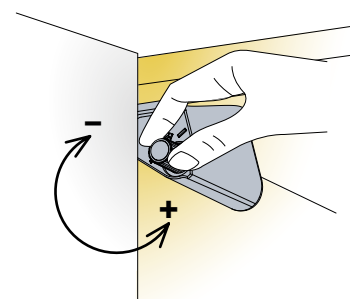

Damping adjustment

- Simple mounting
- Intuitive damping adjustment

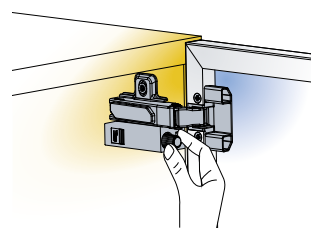

Turn towards '+' to increase and '-' to decrease the damping

Glissando

Titus Damper Inside

Titus Hydraulic Damper

Efficient modular design

- Low number of assembly parts enables quick development of customised solutions
- Engineered for efficient and high precision manufacturing
- Wide range of applications



Wide operating scope

- High coefficient γ of Titus damper assures efficient damping at any closing speed
- Damping force can be easily adapted to customer needs

$$\gamma = \frac{F_H}{F_L}$$

F_H – damping force at slam speed (12mm/s)
 F_L – damping force at slow speed (1mm/s)

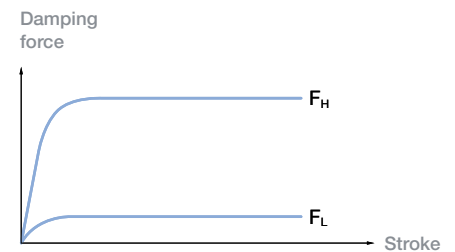

Reliable damping and closing at any speed

Higher coefficient γ means reliable damping at high speed and ensures that the system will reach its final position even at very slow speed

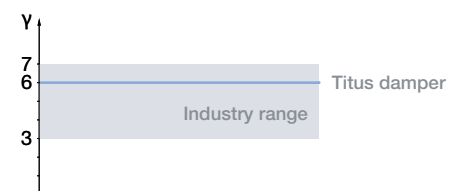





Glissando TT

Glissando TL3

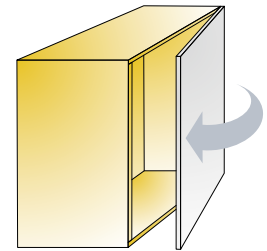
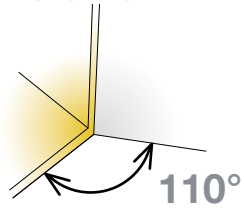
Add-on Hinge Damper

For 95°, 110° and 120° hinges

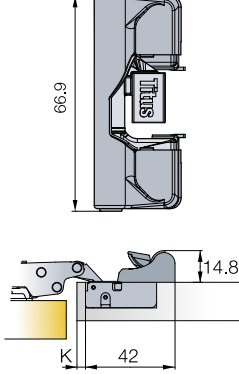

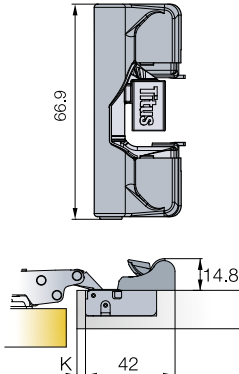
Technical details		Hinge opening angle	Item number
<p>Glissando TT</p> <ul style="list-style-type: none"> · T-type 95 · T-type 110 · T-type 120  <p>200 Pcs Made of steel and plastic</p>		95°, 110°, 120°	729-0K71-054
<p>Glissando TL3</p> <ul style="list-style-type: none"> · S-type 110 · B-type 110  <p>200 Pcs Made of steel and plastic</p>		110°	951-0D45-054

- Same item can be used on most of crankings and angled hinges
- Intuitive snap-on mounting
- Low protrusion in cabinet interior
- Consistent performance across a broad range of furniture doors

Mounting details

Tool-less mounting

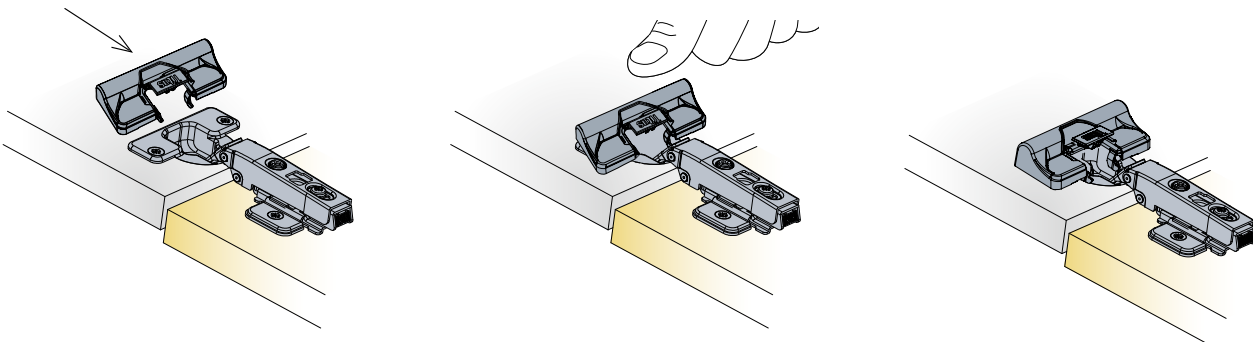

Insert Glissando TL into the holes on the hinge

Press down

Dismounting details

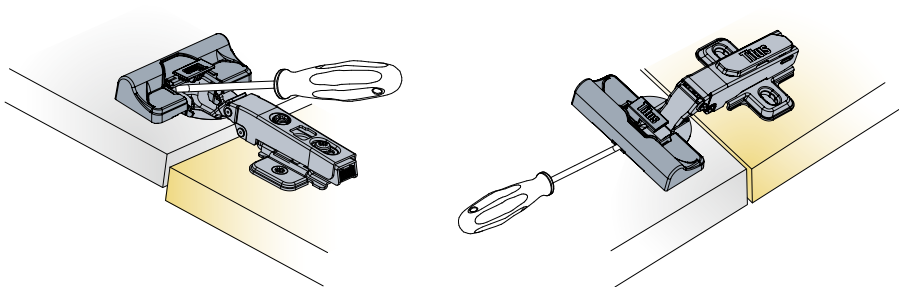

Use flat screwdriver

A trial mounting is always recommended.

Recommended number of Glissandos per door

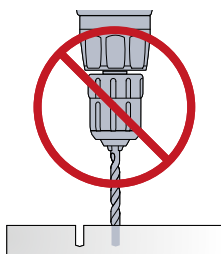

No additional drilling is required

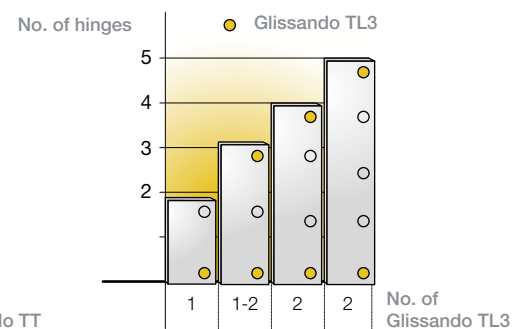
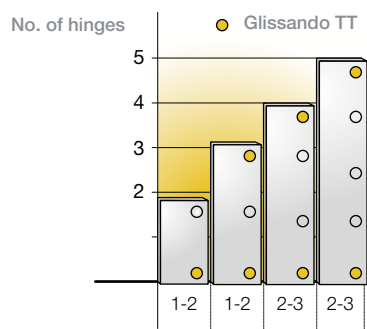

Glissando TL 170

Add-on Hinge
Door Soft Close

For T-type 170, S-type 170 and B-type 170

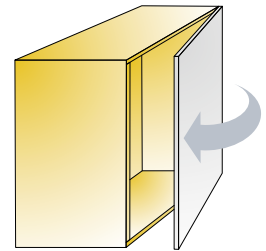
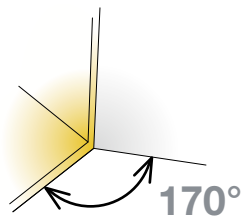

Technical details

Hinge
opening angle

Item
number

Glissando TL 170

170°

951-0F15-650



Soft closing mechanism

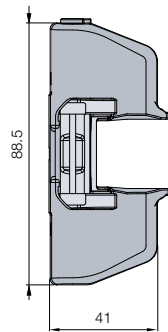

Box content
100 pcs soft closing
mechanisms
100 pcs striking plates



Striking plate

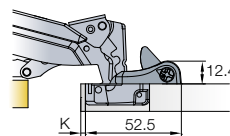

 100 Pcs Made of steel and plastic

- Gentle and reliable soft closing on doors with wider opening angle
- Fits perfectly 45/9.5mm, 48/6mm and 52/5.5mm hinge cups
- ConfidentClose
- Tool-less mounting

Damping adjustment

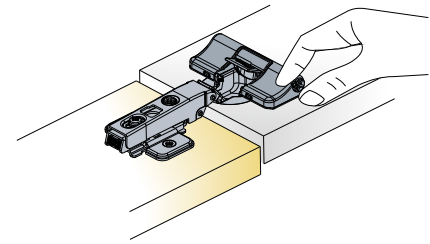

Turn towards '+' to increase and '-' to decrease the damping

Mounting details

Tool-less mounting

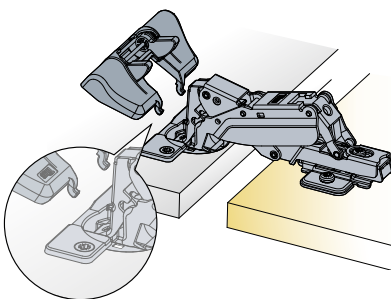

Insert Glissando TL 170 into the holes on the hinge cup

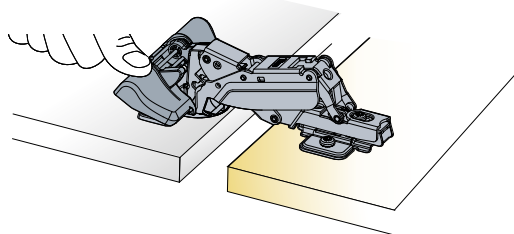

Press down

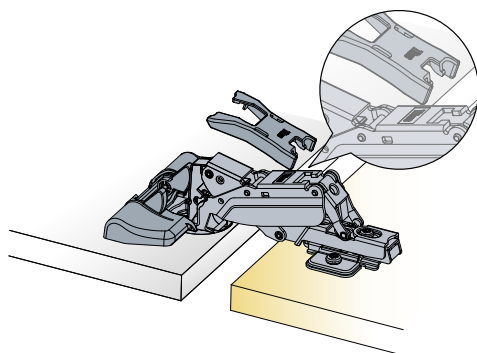

Place the striking plate into the hole on the hinge arm

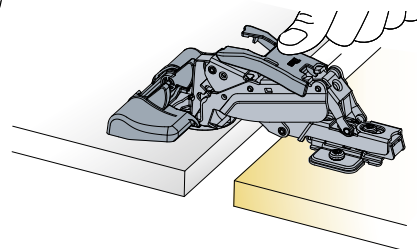

Press down

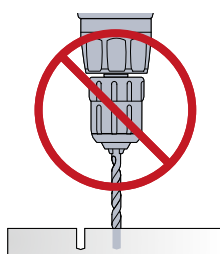
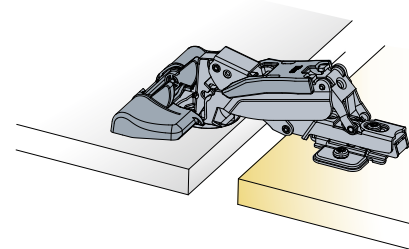

No additional drilling is required

Recommended number of Glissandos per door

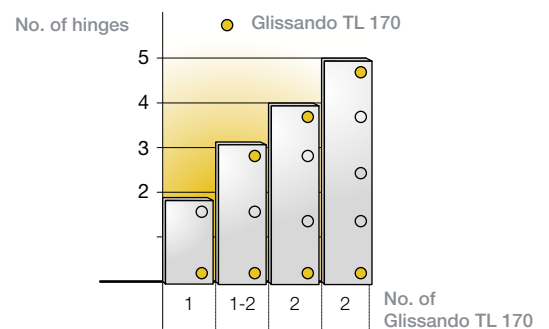

Glissando AL

Add-on Hinge

Door Soft Close

For 20mm aluminium frame doors

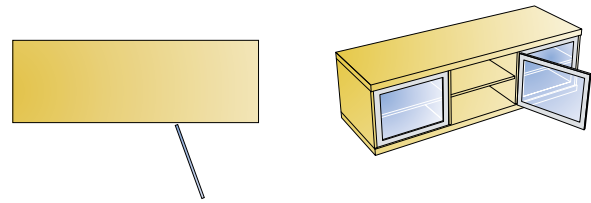

- Simple mounting
- Intuitive damping adjustment

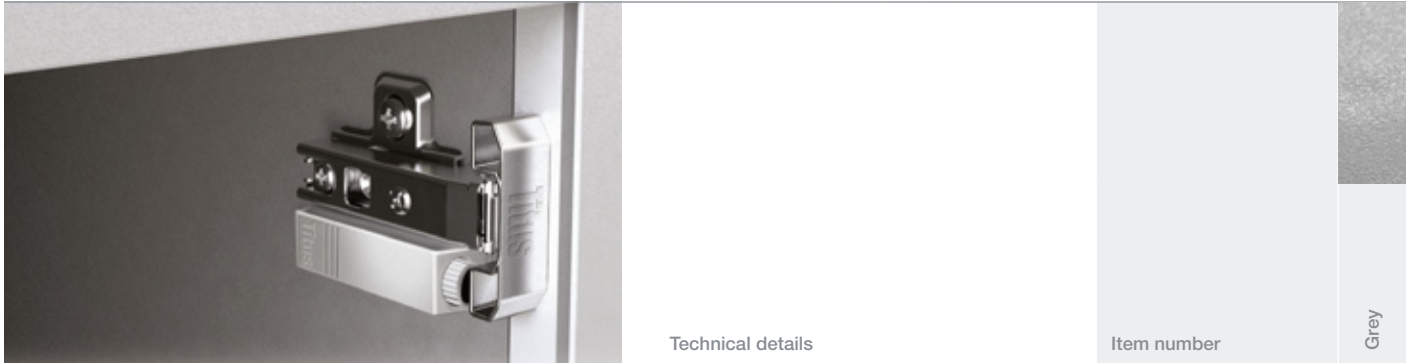

Technical details

Item number

Grey

Glissando AL

972-0420 →

380

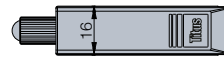
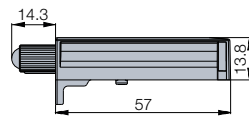

200 Pcs

Full overlay mounting plate

972-4564 →

380

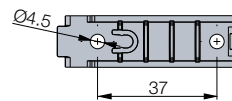
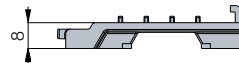

200 Pcs

Half overlay mounting plate

972-4565 →

380

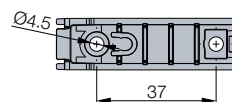
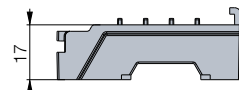

200 Pcs

Inset door mounting plate

972-4566 →

380

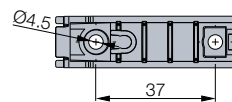
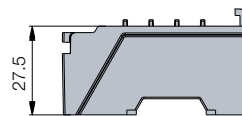

200 Pcs

Hinge cup screws
If not pre-mounted

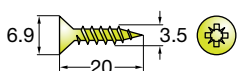

972-6344-042

1000 Pcs

- Simple mounting
- Intuitive damping adjustment

Damping adjustment

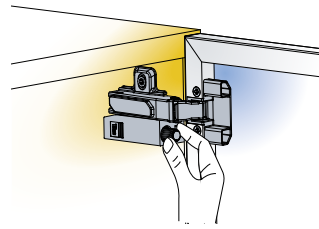

Turn towards '+' to increase and '-' to decrease the damping

Mounting procedure

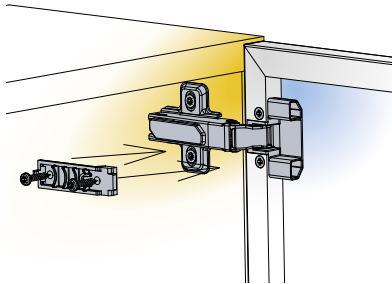

Position the mounting plate below the hinge arm and fix it with two screws. Use hinge mounting plate as a reference.

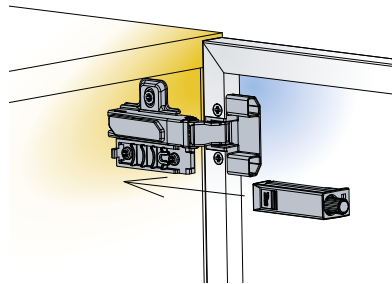

Slide Glissando AL onto the mounting plate.

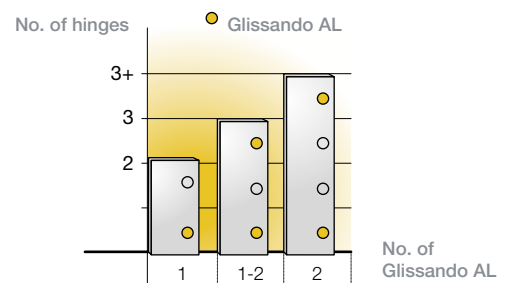
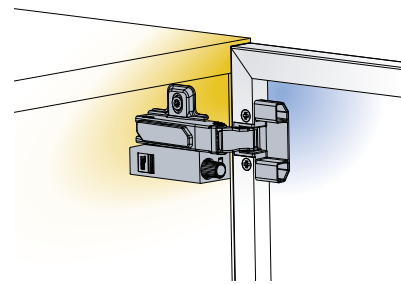

Recommended number per door

Glissando CR

Stand-alone Door Soft Close

For full overaly and half overaly
concealed hinges

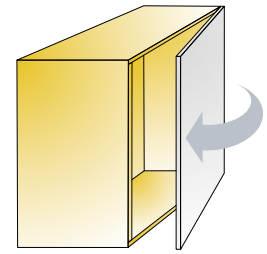

Technical details

Hinge opening angle	Cranking	Item number	White housing	Grey housing	Beige housing
---------------------	----------	-------------	---------------	--------------	---------------

Glissando CR
for full overlay
hinges



Nominal 11
(Adjustment: Nominal + 5mm)

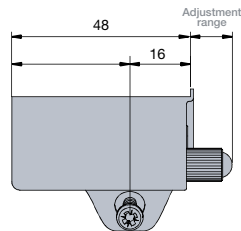

110°	0mm, 5mm	972-0X19 →	350	380	360
------	-------------	------------	-----	-----	-----

*Fixing screw included in a set

100 Pcs Made of plastic

Glissando CR
for half overlay
hinges



Nominal 10
(Adjustment: Nominal + 5mm)

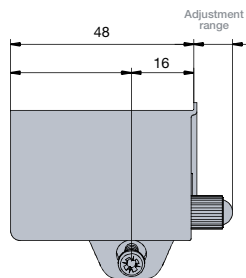

110°	9mm, 17mm	972-0X34 →		380	
------	--------------	------------	--	-----	--

*Fixing screw included in a set

100 Pcs Made of plastic

- Intuitive 'place and fix' installation in the corner of the cabinet
- Tool-less damping adjustment
- One item for a wide range of doors
- Reliable performance

Damping adjustment

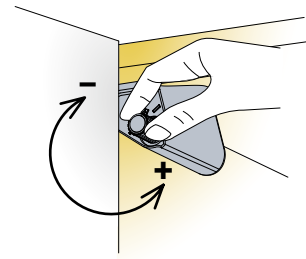

Turn towards '+' to increase and towards '-' to decrease the damping

Mounting details

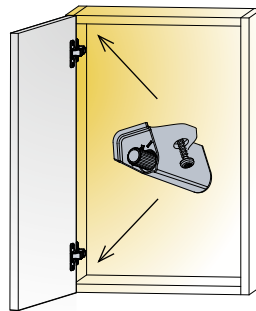
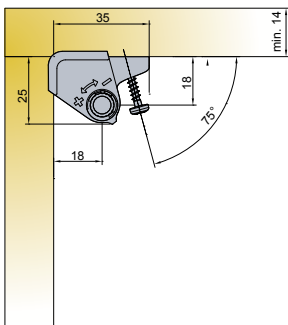

Mount Glissando CR on the hinged side of the cabinet

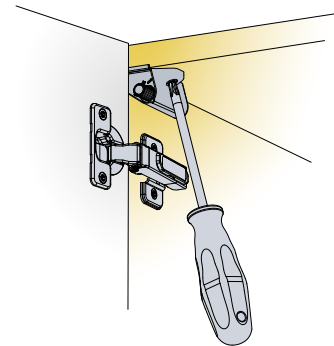

One screw fixing

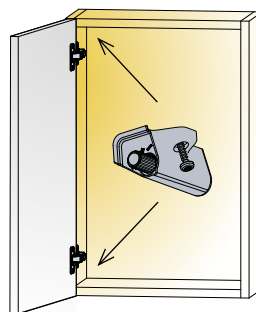
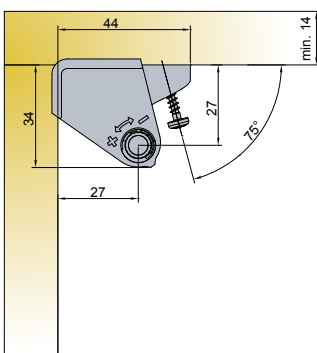

Mount Glissando CR on the hinged side of the cabinet

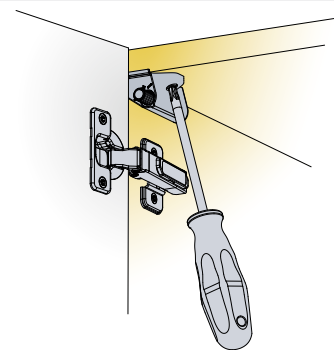

One screw fixing



The functioning of Glissando CR depends of the hinge's closing force. A trial mounting is always recommended.

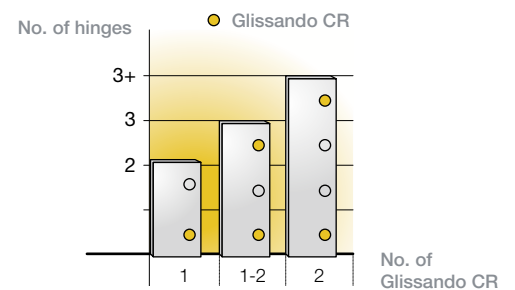

Recommended number per door

PushOpen Solutions



A comprehensive range of solutions for handleless cabinets

- For doors and drawers
- Surface mounted or built-in
- With or without magnet

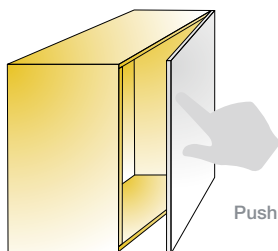

Effortless touch opening

- Easy opening with minimum effort
- Gentle, reliable closing with just a light touch

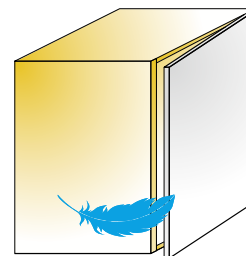

Reliable performance

- Reliable door opening and closing throughout the life-time

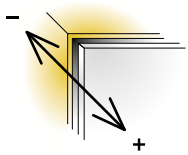
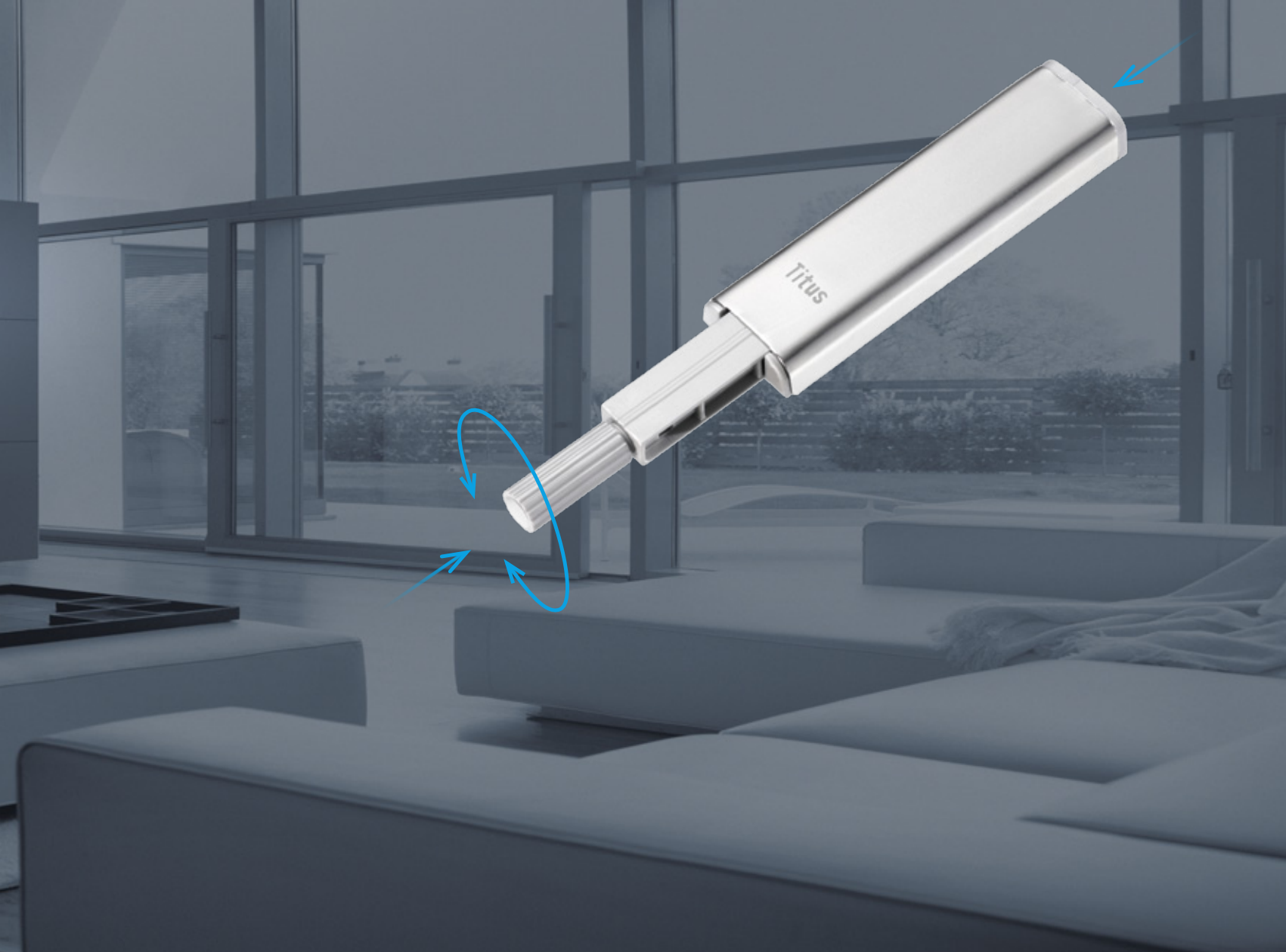

Toolless door gap adjustment

- Easy to compensate any door gaps that might occur during installation
- Simple turn of the adjustment button by hand
- Ensures reliable closing and opening of doors or drawers

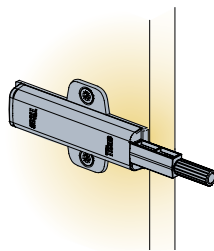

Safety detachment

- Push Latch easily disengages from the mounting plate in case of accidental hits
- Secure detachment



TeraBlack

- Non-reflective matte surface reduced visual prominence of hardware in cabinet
- Complements and enhances all types of furniture
- Enhanced corrosion resistance

Push Latch

For wood doors and drawers

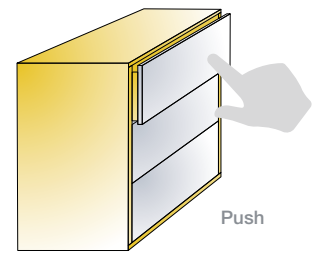
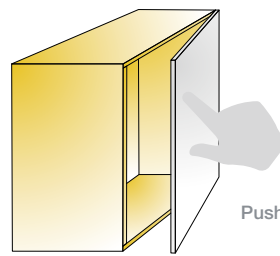

Push Latch



Push Latch



Cruciform mounting plate



Linear mounting plate



200 Pcs

Made of steel and plastic

	Spring force [N] (released)	Spring force [N] (loaded)	Item number	Bronze
With bumper	10	20	915-0X59 →	381
With bumper	13	27	915-0320 →	381
With magnet	10	20	915-0D22 →	381
Linear m. plate			915-4175 →	381
Cruciform m. plate			915-4183 →	381
Sets:				
	Cruciform m. plate		Linear m. plate	
With bumper	915-0X59-381-K1		915-0X59-381-K2	
	200 Sets		200 Sets	
With magnet	915-0D22-381-K1		915-0D22-381-K2	
	200 Sets		200 Sets	

Fixing screws for mounting plates

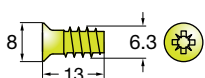

Euro screws
821-6323-050

5000 Pcs

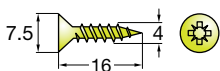

Chipboard screws
820-6328-050

10000 Pcs

Accessories for Push Latch with magnet (Nickel plated steel)

Counter plate self adhesive

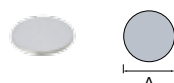

A = Ø15

915-7159-050 500 Pcs

Counter plate

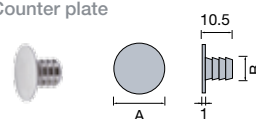

A = Ø10 B = Ø5

915-7196-050 500 Pcs

A = Ø15 B = Ø8

915-7190-050 500 Pcs

Knock-in Counter plate

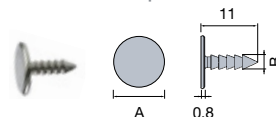

A = Ø10 B = Ø2.8

915-7199-050 500 Pcs

- Effortless opening with just a light touch
- Depth adjustment ensures reliable closing and consistent performance in case of inaccurate drilling
- 'Safety click' feature for easy detachment of the mechanism from its mounting plate

Door adjustment

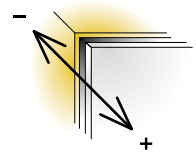

Depth adjustment
+4.5/-1mm

i PushOpen with bumper works with standard hinge
PushOpen with magnet works with reverse spring or unsprung hinges

Drilling pattern

Dimensions

Depth adjustment

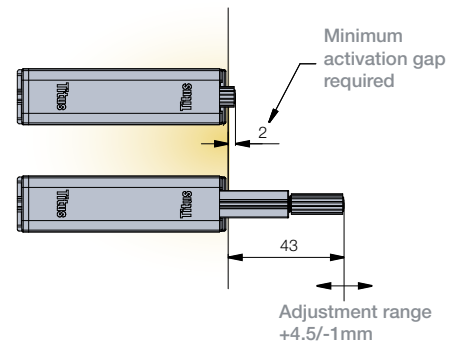
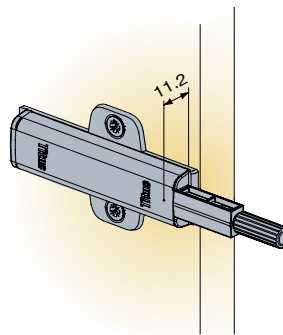
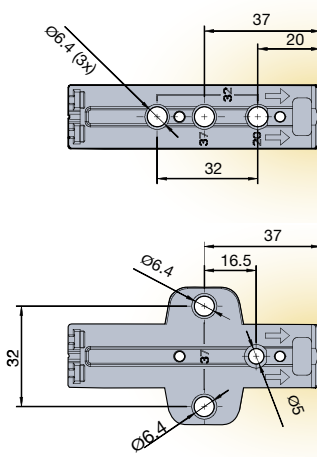

Positioning

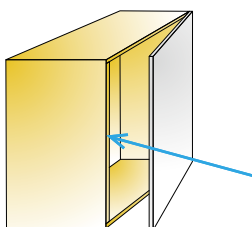

Close to the 'touch opening point' on the side opposite to hinges

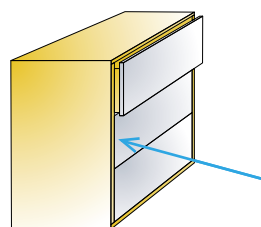

On the cabinet side; gap between drawer and cabinet side 12mm min

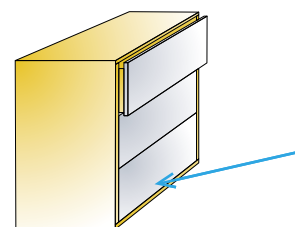

On the drawer bottom; in the middle of drawer

PushOpen Short

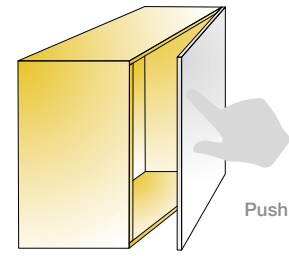

Stroke [mm]	Item number	White	Grey	Lead grey	Black
-------------	-------------	-------	------	-----------	-------

PushOpen Short

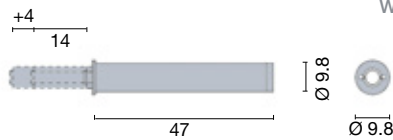

With bumper

14	915-7187 →	350	380	383	390
----	-------------------	-----	-----	-----	-----

With magnet

14	915-7185 →	350	380	383	390
----	-------------------	-----	-----	-----	-----

100 Pcs Made of steel and plastic

Housing Short

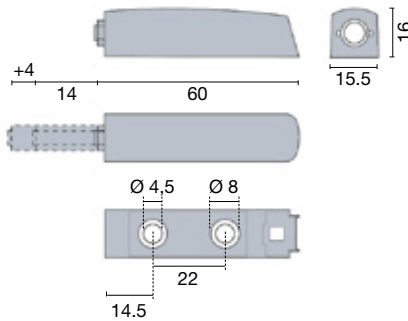

915-7192 →	350	380	383	390
-------------------	-----	-----	-----	-----

100 Pcs Made of plastic

Fixing screws for housing

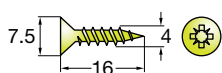

Chipboard screws
820-6328-050
10000 Pcs

Accessories for PushOpen with magnet (Nickel plated steel)

Counter plate self adhesive

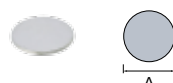

A = Ø15 **915-7159-050** 500 Pcs

Counter plate

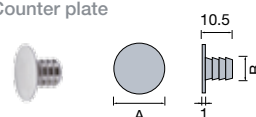

A = Ø10 B = Ø5 **915-7196-050** 500 Pcs

A = Ø15 B = Ø8 **915-7190-050** 500 Pcs

Knock-in Counter plate

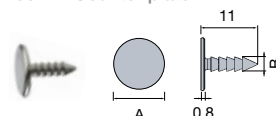

A = Ø10 B = Ø2.8 **915-7199-050** 500 Pcs

- Effortless opening with just a light touch
- Depth adjustment ensures reliable opening

Door adjustment



PushOpen with bumper works with standard hinge
PushOpen with magnet works with reverse spring or unprung hinges

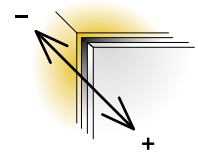

Depth adjustment
+4/0mm

Drilling pattern and mounting procedure

Depth adjustment

Without housing

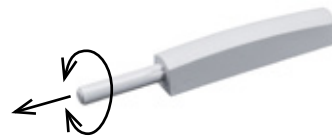
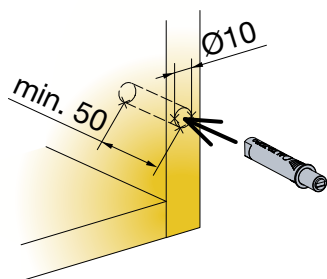

Adjustment made by rotating the depth adjustment screw

With housing

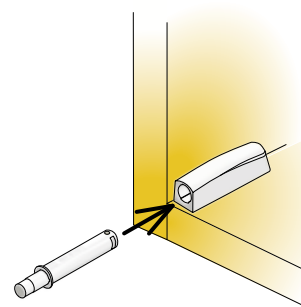
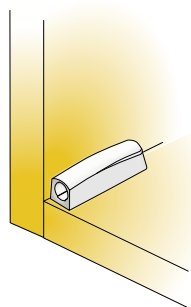
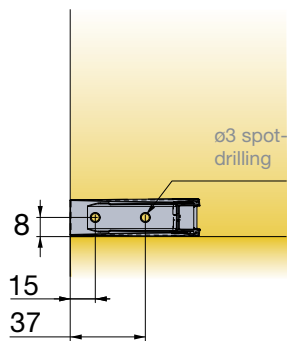

Application on door for Counter plates

Application on door for Counter plate with double side tape and knock-in counter plate

Positioning

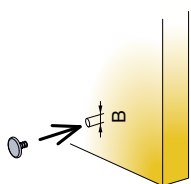

Pre-drilled hole
ØB x 10mm

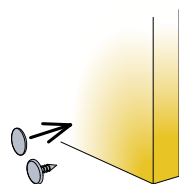

Sticking or knock-in position

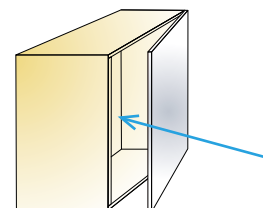

Close to the 'touch opening point' on the side opposite to hinges

PushOpen Long

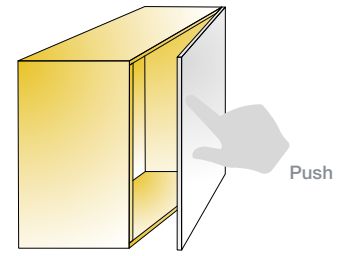

Stroke [mm]	Item number	White	Grey	Lead grey	Black
-------------	-------------	-------	------	-----------	-------

PushOpen
Long



With bumper

37 **915-7188** → 350 380 383 390

With magnet

37 **915-7186** → 350 380 383 390

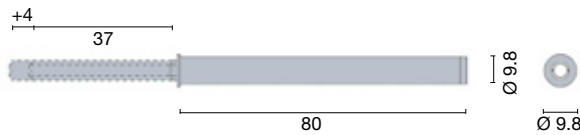

100 Pcs Made of steel and plastic

Housing
Long

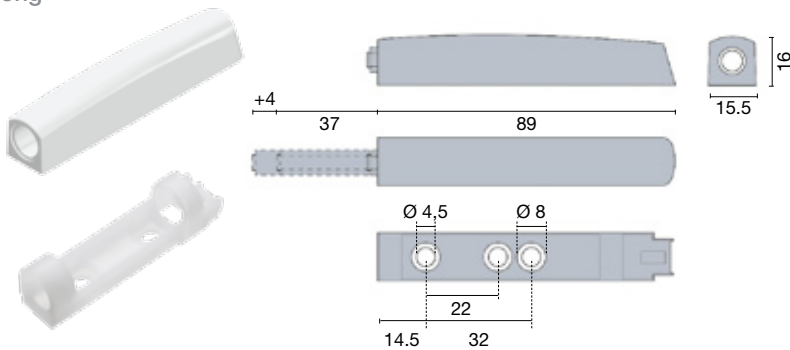

915-7193 → 350 380 383 390

100 Pcs Made of plastic

Fixing screws for housing

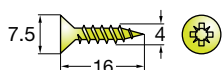

Chipboard screws
820-6328-050

10000 Pcs

Accessories for PushOpen with magnet (Nickel plated steel)

Counter plate self adhesive

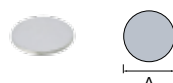

A = Ø15

915-7159-050 500 Pcs

Counter plate

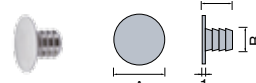

A = Ø10 B = Ø5

915-7196-050 500 Pcs

A = Ø15 B = Ø8

915-7190-050 500 Pcs

Knock-in Counter plate

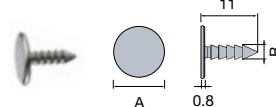

A = Ø10 B = Ø2.8

915-7199-050 500 Pcs

- Effortless opening with just a light touch
- Depth adjustment ensures reliable opening

Door adjustment



PushOpen with bumper works with standard hinge
PushOpen with magnet works with reverse spring or unprung hinges

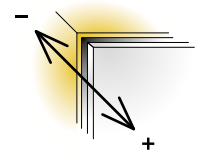

Depth adjustment
+4/0mm

Drilling pattern and mounting procedure

Depth adjustment

Without housing

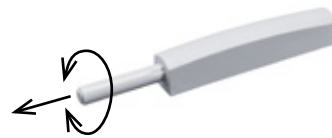
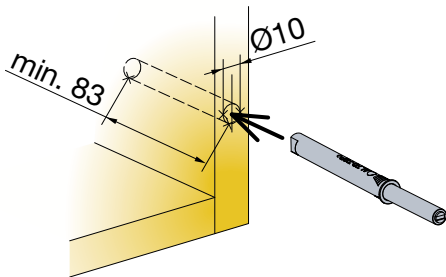

Adjustment made by rotating the depth adjustment screw

With housing

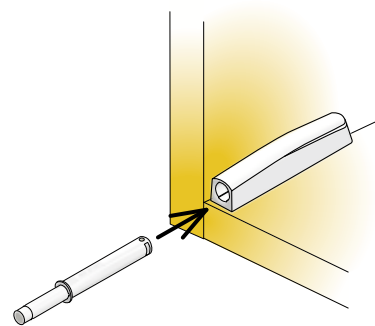
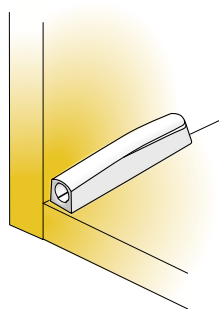
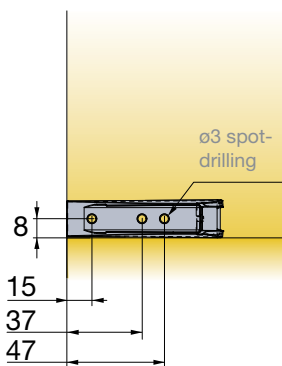

Application on door for Counter plates

Application on door for Counter plate with double side tape and knock-in counter plate

Positioning

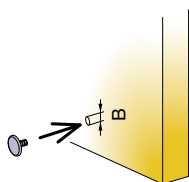

Pre-drilled hole
ØB x 10mm

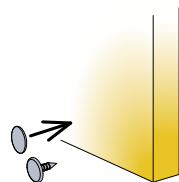

Sticking or knock-in position

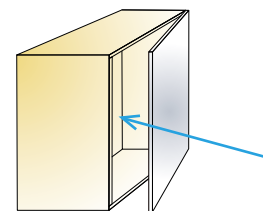

Close to the 'touch opening point' on the side opposite to hinges

Tekform Slimline Drawer

Tekform Slimline Drawer

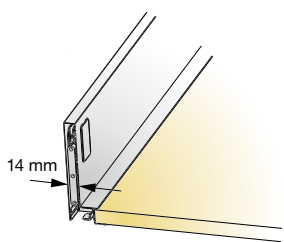
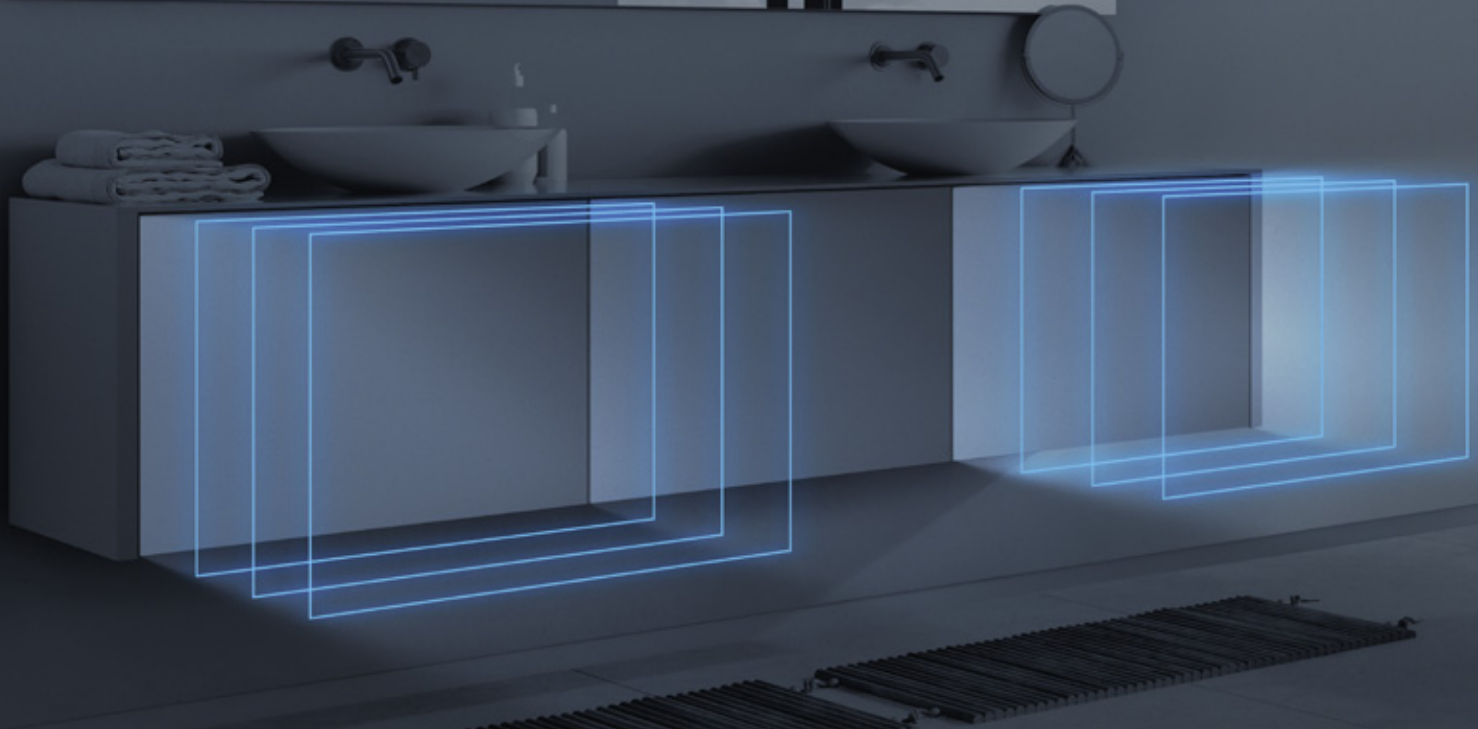

Sleek look

- 14mm side thickness
- Efficient utilisation of drawer space

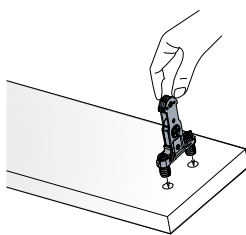

'EasyFix' front panel connector

- Hand insertion
- Quarter turn lock
- Repeatable assembly and disassembly possible

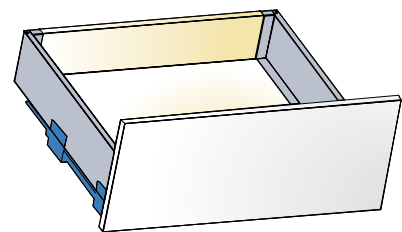

Flexibility in use

- Same runner system as 1st generation Tekform drawer
- Same panel cutting dimensions and drilling specification as 1st generation Tekform drawer

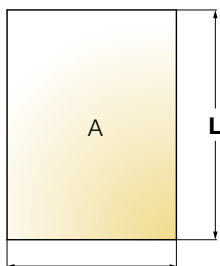

Expanded tolerances

- Precise drawer alignment
- Smooth and silent operating
- Improved drawer stability in open position
- +/-1mm tolerance on bottom panel width size



Titus damper inside

- Life-long consistent soft closing at various closing speeds
- 'ConfidentClose' - fast closing, late start of damping, quiet landing
- Low pull-out force



Tekform Slimline Tacto

- For effortless touch opening of Slimline drawer
- Narrow 1.5mm operating gap for evenly aligned fronts
- Fast and intuitive mounting without pre-drilling
- Non-handed design

Tekform Slimline Drawer

Product Guide

Page

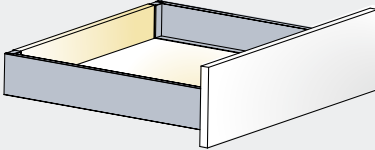
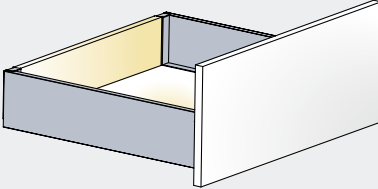
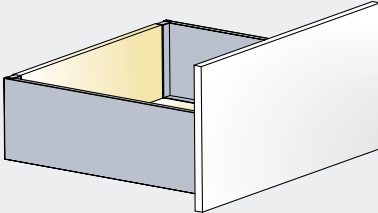
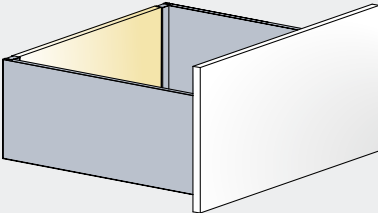
Tekform Slimline Drawer		Side material	Drawer type	
Tekform Slimline drawer DW70		Metal	Soft closing	3.13
		Metal	Touch opening + Soft closing	3.15
		Glass	Soft closing	3.17
Tekform Slimline drawer DW100		Metal	Soft closing	3.19
		Metal	Touch opening + Soft closing	3.21
Tekform Slimline drawer DW145		Metal	Soft closing	3.23
		Metal	Touch opening + Soft closing	3.25
		Glass	Soft closing	3.27
Tekform Slimline drawer DW182		Metal	Soft closing	3.29
		Glass	Touch opening + Soft closing	3.31
		Glass	Soft closing	3.33

Inner Slimline Drawer Fronts

Inner drawer front for Tekform Slimline drawer DW70

3.35

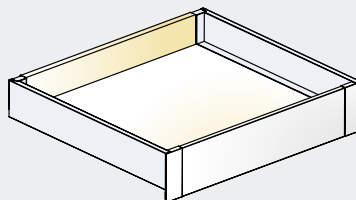

Inner drawer front for Tekform Slimline drawer DW70 with glass

3.37

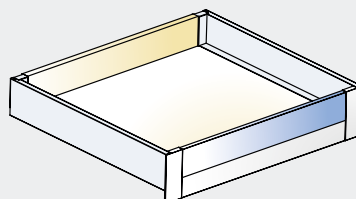

Page

Inner drawer front for
Tekform Slimline Drawer
DW145 with bar

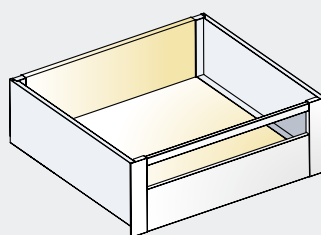

3.39

Inner drawer front for
Tekform Slimline drawer
DW145 with high glass

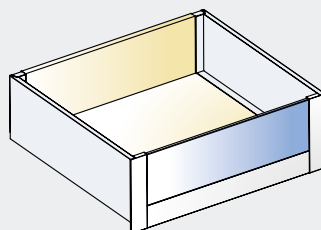

3.41

Inner drawer front for
Tekform Slimline drawer
DW182 with bar

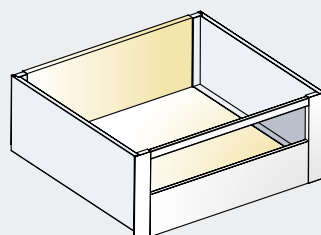

3.43

Inner drawer front for
Tekform Slimline drawer
DW182 with high glass

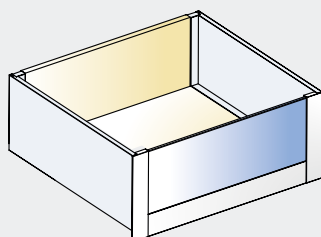

3.45

Accessories

Tacto Slimline 3.47

Marking jig 3.49

Steel back panel 3.50

Tekform Slimline Drawer Information

Technical Guide

How to choose the appropriate drawer dimension?

Select the drawer size based on available cabinet space. Please refer to the chart below with indicated minimum space

required in cabinet to choose appropriate drawer system.

Tekform drawer nominal length (NL) inmm

NL	270	300	350	400	450	500	550
----	-----	-----	-----	-----	-----	-----	-----

	Tekform drawer		Tekform drawer with inner front	
	Min. height H required	Cabinet depth D	Min. height H required	Cabinet depth D
Tekform Slimline drawer DW70	115mm	NL + min 3mm	115mm	NL + min 12mm
Tekform Slimline drawer DW100	147mm	NL + min 3mm	/	/
Tekform Slimline drawer DW145	198mm	NL + min 3mm	198mm	NL + min 12mm
Tekform Slimline drawer DW182	230mm	NL + min 3mm	230mm	NL + min 12mm

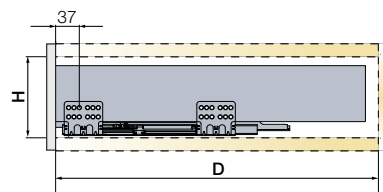

How to fix drawer sides to the front panel?

The Tekform drawer is available with 'EasyFix' or screw-in front connectors



'EasyFix' front connector

- hand insertion
- quarter turn locking system
- expandable plastic dowel
- easy assembly and disassembly of front panel

Front connector

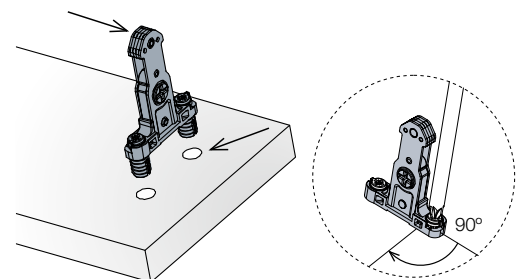

Screw-in front connector

- reliable connection
- fixing with Ø3.5x15mm screw (screws are not included)

Front connector

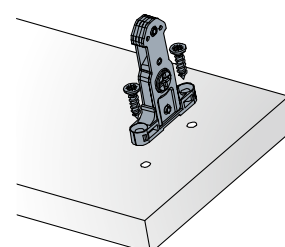

Bottom panel and back panel cutting dimensions

Dimensions of bottom and back panel depends on:

- cabinet width
- nominal drawer length
- drawer height

Tekform drawer nominal length (NL) inmm

NL	270	300	350	400	450	500	550
----	-----	-----	-----	-----	-----	-----	-----

Cabinet width

ECW: External cabinet width
ICW: Internal cabinet width
NL: Nominal length of drawer

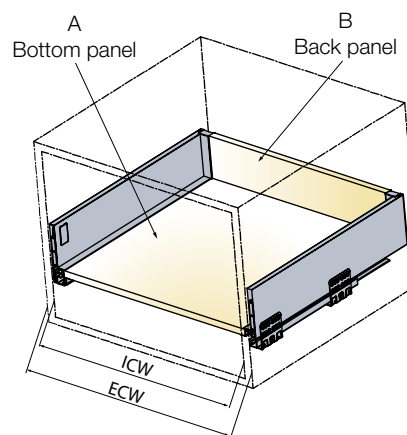

Back panel cutting dimensions

Back panel height depends on the selected drawer height

	H back panel
SDWD70	68
SDWD100	100
SDWD145	151
SDWD182	183

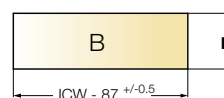

Bottom panel cutting dimensions

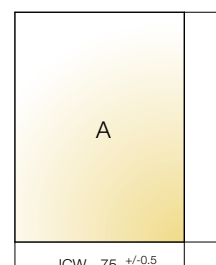

NL	270	300	350	400	450	500	550
L	260	290	340	390	440	490	540
L_{st}	250	280	330	380	430	480	530

NL = Tekform drawer nominal length (mm)
L_{st}: Length in case of steel back panel

Tekform Slimline Drawer Information

Technical Guide

How to choose the appropriate drawer runner fixing positions?

Drawer fixing positions depend on the chosen drawer front type.

Tekform Slimline drawer with standard front

When a standard drawer front is applied, use the third hole on the drawer runner for fixing.

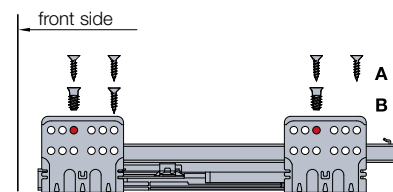

Tekform Slimline drawer with inner front

When an inner drawer front is applied, use the second hole on the drawer runner for fixing.

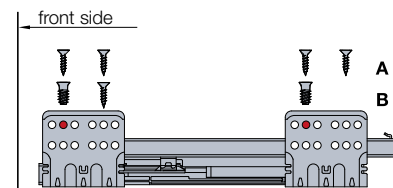

Load capacity

Drawer load capacity is 40 kg.

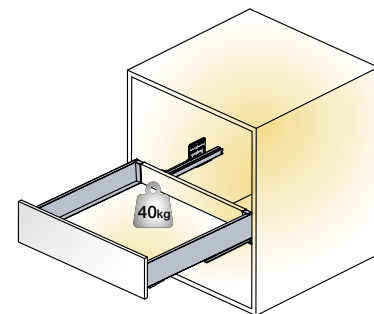

Expanded tolerances

Tekform drawers provide wider tolerances in cabinet construction and assures:

- precise drawer alignment
- smooth and silent operating
- Improved drawer stability in open position
- Tekform drawer provides tolerance of +/- 1mm on bottom panel width size

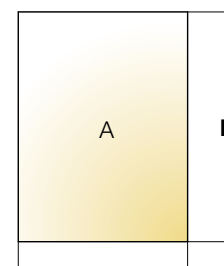

bottom panel width tolerance +/- 1mm



Adjustment needs to be done on both sides of the drawer

Adjustments

Side adjustment

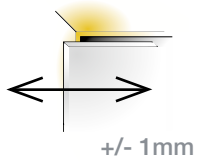

Side adjustment is done through the adjustment screw on the drawer side.

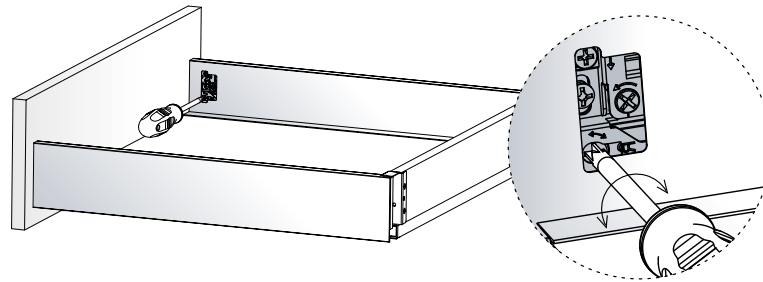

Height adjustment

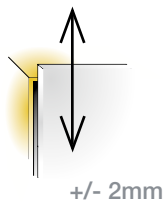

Release first the locking screw and tighten it back after the front is adjusted.

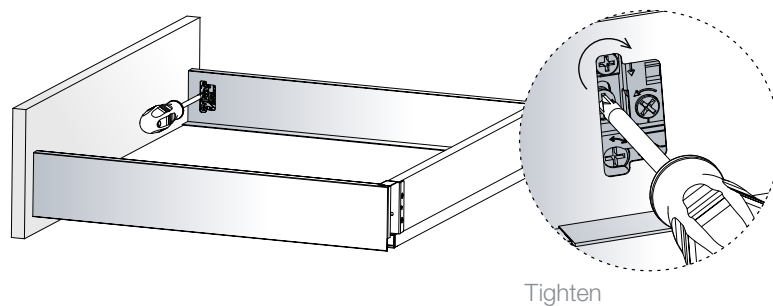
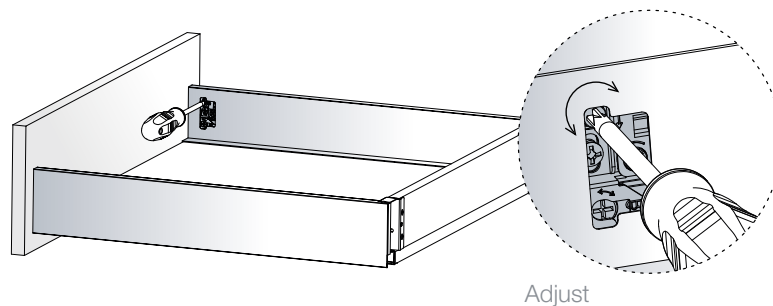
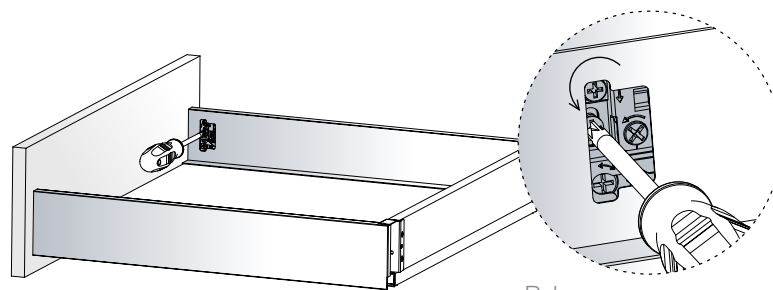

Tekform Slimline Drawer Information

Key Design Choices

'ConfidentClose'

Fast closing

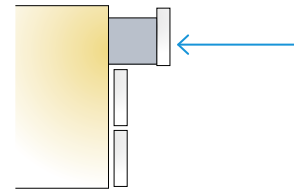

Late start of damping

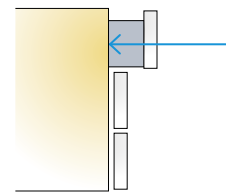

Quiet landing

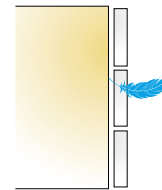

CAF Consumer Assembly Friendliness

'EasyFix' front panel connector with expandable plastic dowel provides:

- Quick, tool-free insertion
- Quarter turn lock
- Repeatable assembly and disassembly

Front connector

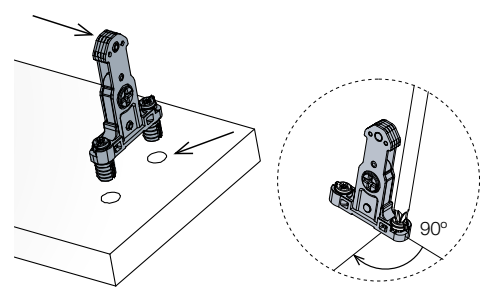

Titus hydraulic damper

Designed and produced in-house

- Reliable and consistent life-long damping
- Smooth closing
- Dampers' consistency over high volume production runs assured
- 100% automated quality check



Damping action

Even and smooth soft closing action
 - Soft and reliable closing

Damping force

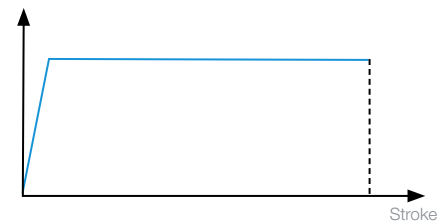

Flat damping curve shows the uniform action produced during damper closing at a defined speed.

Tekform Slimline Drawer DW70

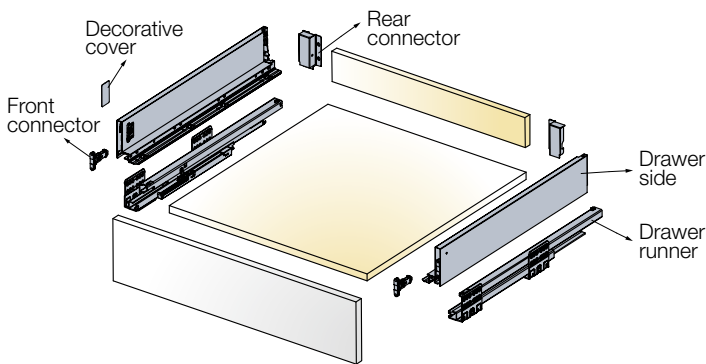
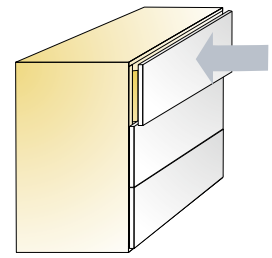

Cutting dimensions details

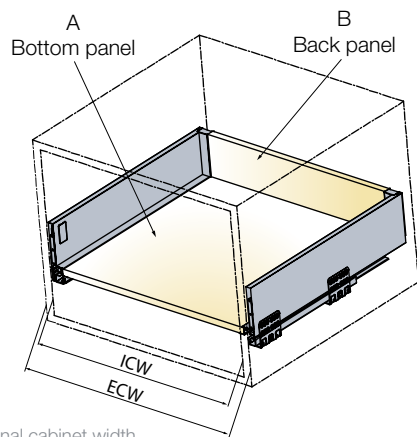

ECW: External cabinet width
 ICW: Internal cabinet width
 NL: Nominal length of drawer
 L_{st} : Length in case of steel back panel

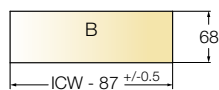
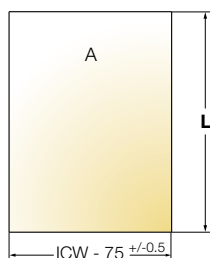

$L = NL - 10$
 $L_{st} = NL - 20$
 For further explanation → see page 3.8

NL	with EasyFix front connector	with Screw-in front connector	White	Antracite grey
	Item number for a set	Item number for a set		
270	655-8T27 →	655-8E27 →	150	185
300	655-8T30 →	655-8E30 →	150	185
350	655-8T35 →	655-8E35 →	150	185
400	655-8T40 →	655-8E40 →	150	185
450	655-8T45 →	655-8E45 →	150	185
500	655-8T50 →	655-8E50 →	150	185
550	655-8T55 →	655-8E55 →	150	185

One set consists of

Drawer sides		2 pcs
Drawer runners		2 pcs
*Front connectors		2 pcs
Rear connectors		2 pcs
Covers		2 pcs 2 pcs
Mounting instructions		1 pc/4 sets

4 sets

Screws are not included

- Drawer runner type
- Load capacity
- Minimum height space required
- Wooden back panel thickness
- Wooden bottom panel thickness

full extension
40 kg
115mm
16mm
16mm

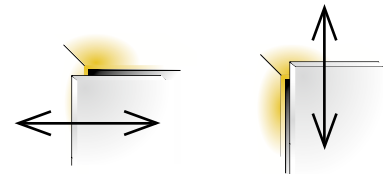

Side adjustment
+1/-1mm

Height adjustment
+2/-2mm

For further explanation → see page 3.10

Installation dimensions

Minimum space required for the cabinet

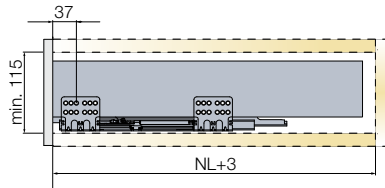

Drilling dimensions for the front panel

EasyFix attachment

Screw-in attachment

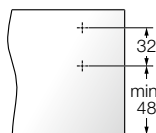
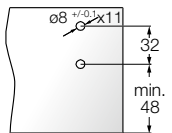

Mounting dimensions for the back panel

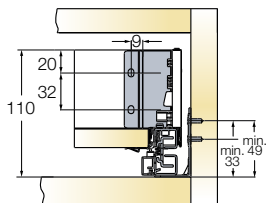

Installation dimensions for the front panel

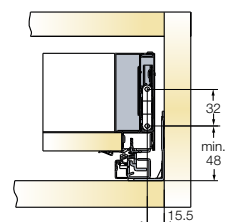

Drawer runner fixing positions

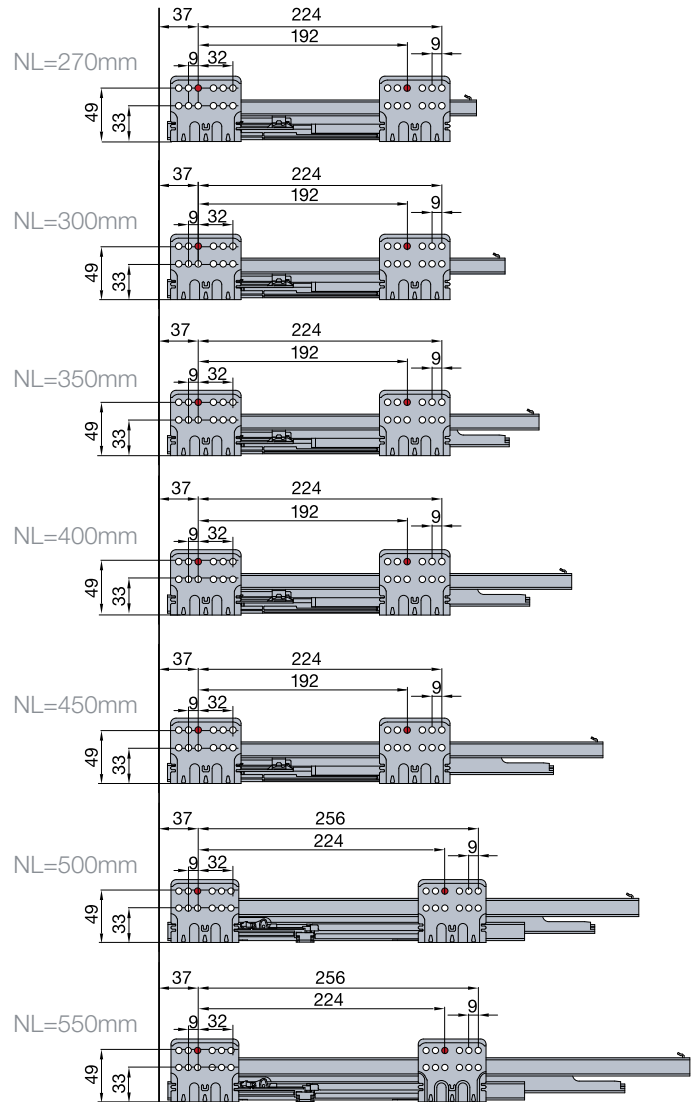
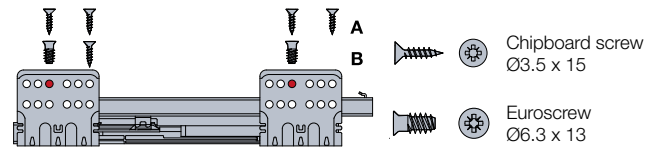

A trial mounting is always recommended.
For further information please contact your
Titus Group representative.

Tekform Slimline Tacto Drawer DW70

Touch Opening System

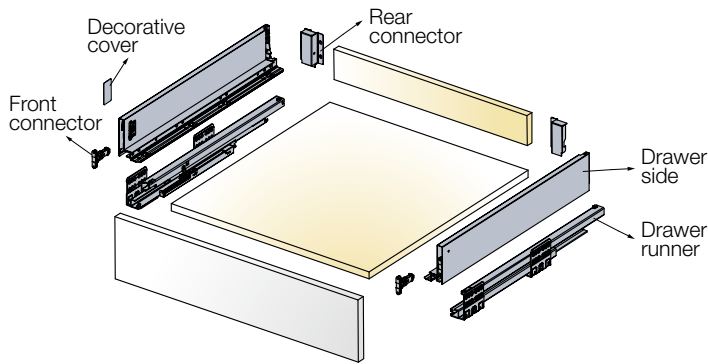
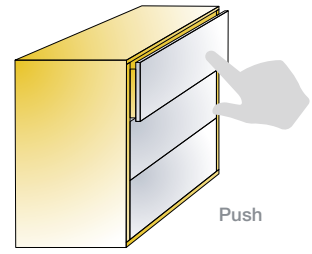

Cutting dimensions details

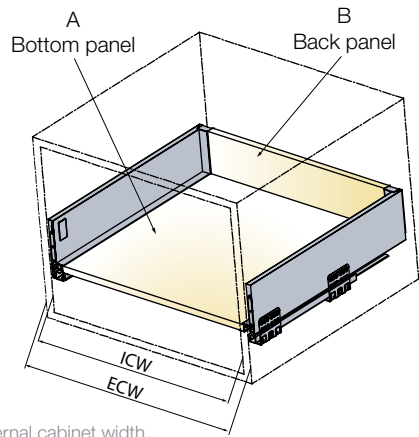

ECW: External cabinet width
 ICW: Internal cabinet width
 NL: Nominal length of drawer
 L_{st}: Length in case of steel back panel

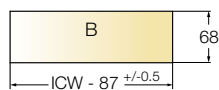
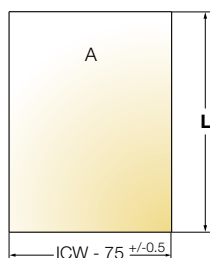

$L = NL - 10$
 $L_{st} = NL - 20$
 For further explanation → see page 3.8

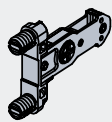
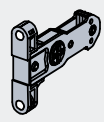
NL	with EasyFix front connector	with Screw-in front connector	White
Nominal length (mm)			
	Item number for a set	Item number for a set	

400	655-8T61 →	655-8E61 →	150
450	655-8T62 →	655-8E62 →	150
500	655-8T63 →	655-8E63 →	150
550	655-8T64 →	655-8E64 →	150

One set consists of	
Drawer sides	 2 pcs
Drawer runners	 2 pcs
*Front connectors	 2 pcs
Rear connectors	 2 pcs
Covers	 2 pcs 2 pcs
Mounting instructions	 1 pc/4 sets



Screws are not included

Touch opening



Tacto Slimline Mechanism
 → see page 3.47

- Drawer runner type
- Load capacity
- Minimum height space required
- Wooden back panel thickness
- Wooden bottom panel thickness

full extension
40 kg
115mm
16mm
16mm

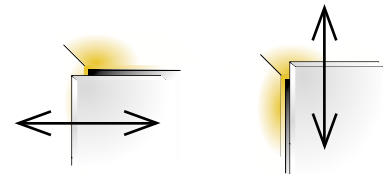

Side adjustment
+1/-1mm

Height adjustment
+2/-2mm

For further explanation → see page 3.10

i Works only with Tacto Slimline Mechanism
→ see page 3.47

Installation dimensions

Minimum space required for the cabinet

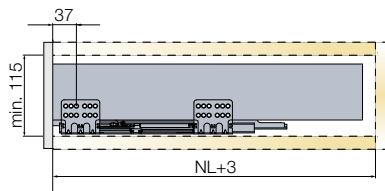

Drilling dimensions for the front panel

EasyFix attachment

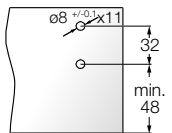

Screw-in attachment

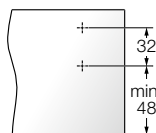

Mounting dimensions for the back panel

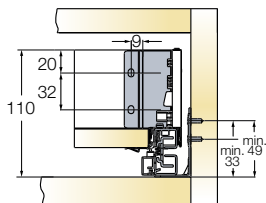

Installation dimensions for the front panel

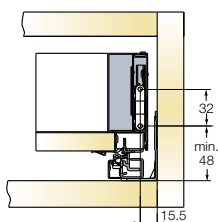

Drawer runner fixing positions

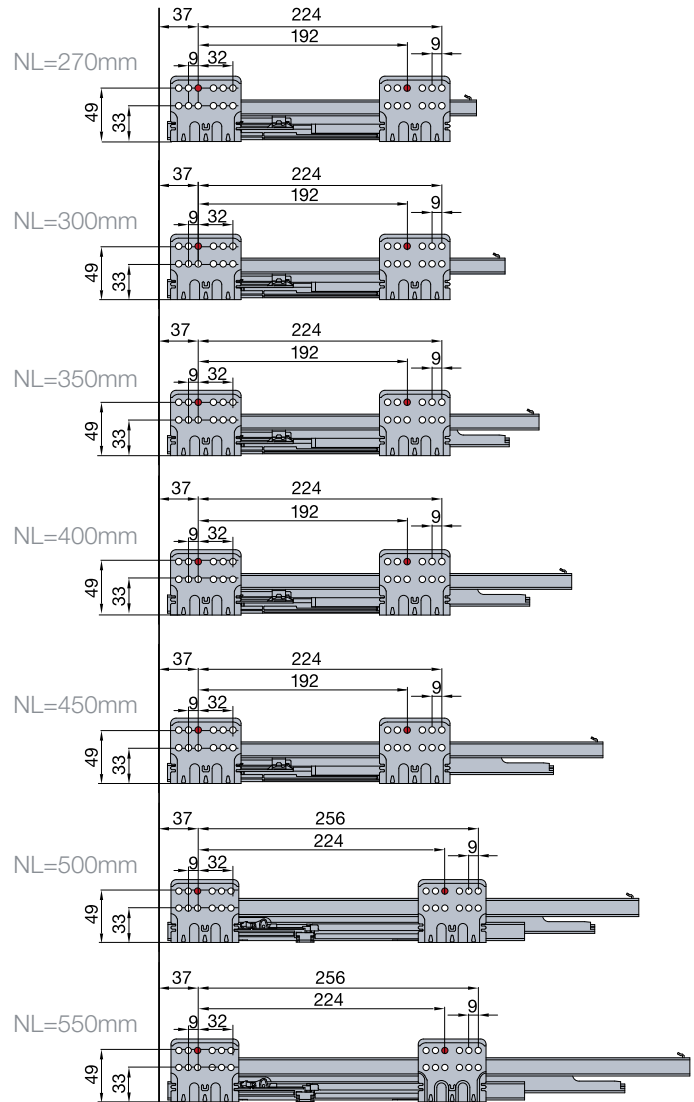
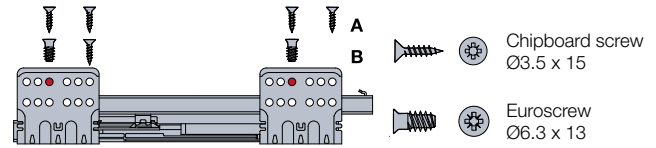

A trial mounting is always recommended.
For further information please contact your Titus Group representative.

Tekform Slimline Drawer DW70 With Glass Sides

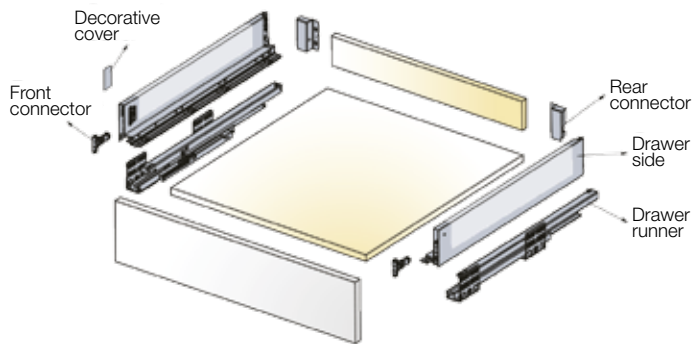
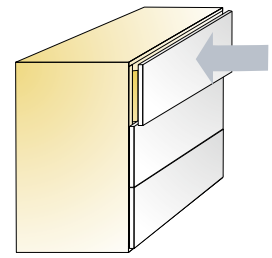



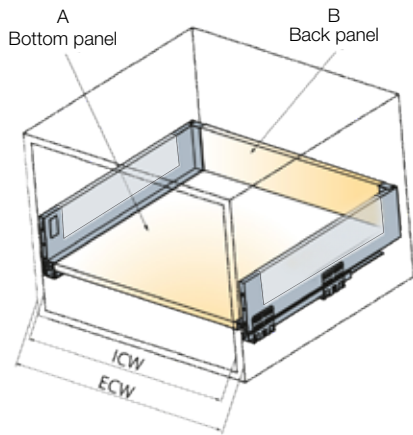

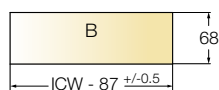
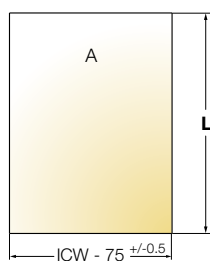

Cutting dimensions details

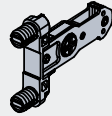
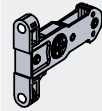

ECW: External cabinet width
 ICW: Internal cabinet width
 NL: Nominal length of drawer
 L_{st}: Length in case of steel back panel



L = NL - 10
 L_{st} = NL - 20
 For further explanation → see page 3.8

NL	with EasyFix front connector	with Screw-in front connector		
			White + Glass	Antracite grey + Glass
Nominal length (mm)	Item number for a set	Item number for a set		
400	655-7P40 →	655-7U40 →	152	187
450	655-7P45 →	655-7U45 →	152	187
500	655-7P50 →	655-7U50 →	152	187
One set consists of				
	Drawer sides		2 pcs	
	Drawer runners		2 pcs	
	Front connectors		2 pcs	
	Rear connectors		2 pcs	
	Covers		2 pcs 2 pcs	
	Mounting instructions		1 pc/6 sets	

 6 sets

Screws are not included

- Drawer runner type
- Load capacity
- Minimum height space required
- Wooden back panel thickness
- Wooden bottom panel thickness
- Tempered glass sides

full extension
40kg
115mm
16mm
16mm
8mm, transparent

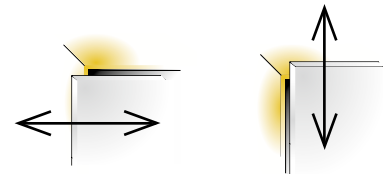

Side adjustment
+1/-1mm

Height adjustment
+2/-2mm

For further explanation → see page 3.10

Installation dimensions

Minimum space required for the cabinet

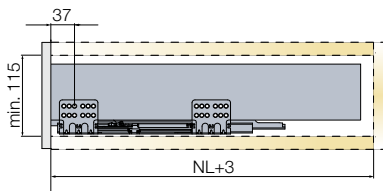

Drilling dimensions for the front panel

EasyFix attachment

Screw-in attachment

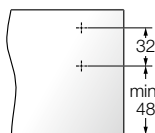
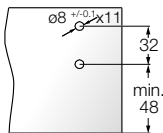

Mounting dimensions for the back panel

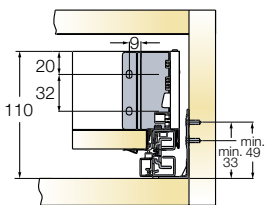

Installation dimensions for the front panel

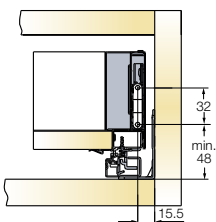

Drawer runner fixing positions

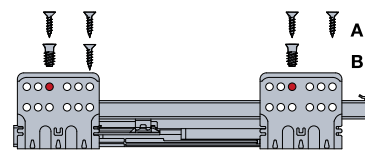

- Chipboard screw
Ø3.5 x 15
- Euroscrew
Ø6.3 x 13

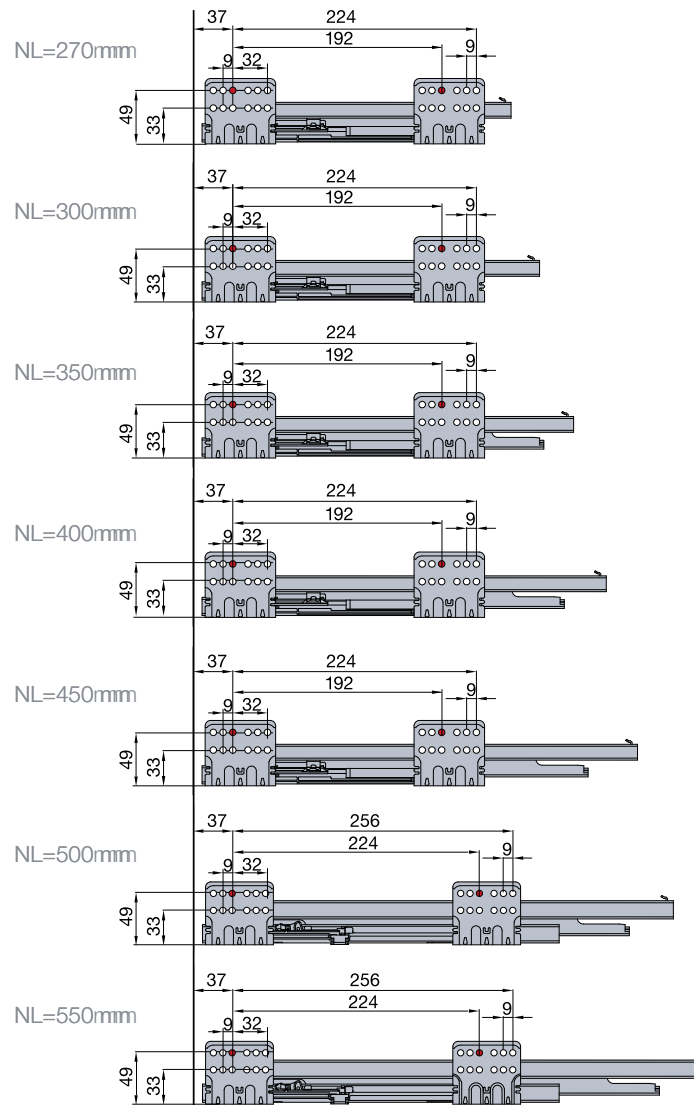

A trial mounting is always recommended.
For further information please contact your
Titus Group representative.

Tekform Slimline Drawer DW100

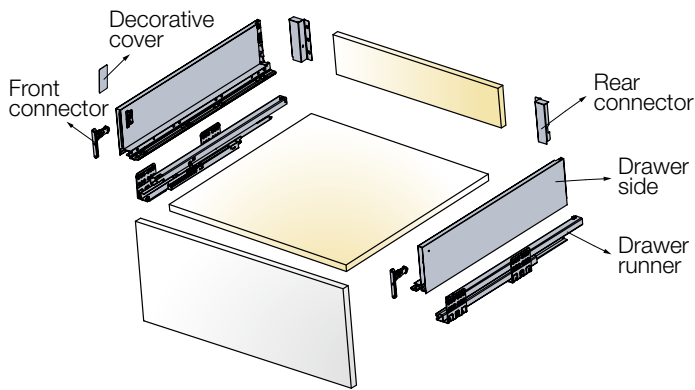
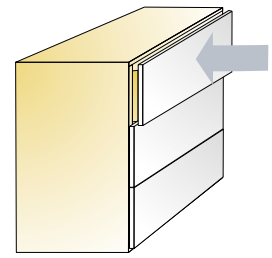

Cutting dimensions details

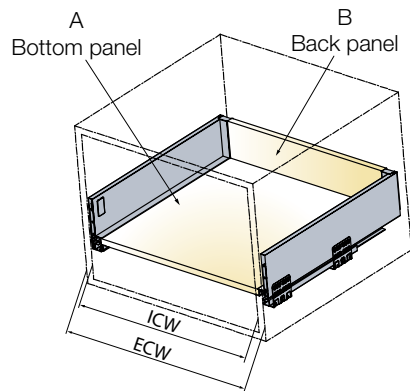

ECW: External cabinet width
ICW: Internal cabinet width
NL: Nominal length of drawer

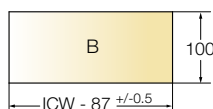
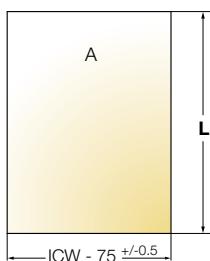

$L = NL - 10$
For further explanation → see page 3.8



NL	with EasyFix front connector	with Screw-in front connector		
Nominal length (mm)				
	Item number for a set	Item number for a set	White	Antracite grey
270	655-8U27 →	655-8F27 →	150	185
300	655-8U30 →	655-8F30 →	150	185
350	655-8U35 →	655-8F35 →	150	185
400	655-8U40 →	655-8F40 →	150	185
450	655-8U45 →	655-8F45 →	150	185
500	655-8U50 →	655-8F50 →	150	185
550	655-8U55 →	655-8F55 →	150	185
One set consists of				
Drawer sides			2 pcs	
Drawer runners			2 pcs	
*Front connectors			2 pcs	
Rear connectors			2 pcs	
Covers			2 pcs	
Mounting instructions			1 pc/4 sets	

Screws are not included

- Drawer runner type
- Load capacity
- Minimum height per drawer required
- Wooden back panel thickness
- Wooden bottom panel thickness

full extension
40 kg
147mm
16mm
16mm

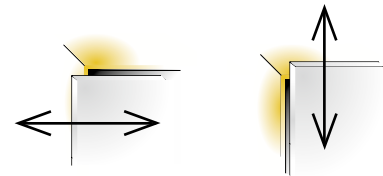

Side adjustment
+1/-1mm

Height adjustment
+2/-2mm

For further explanation → see page 3.10

Installation dimensions

Minimum space required for the cabinet

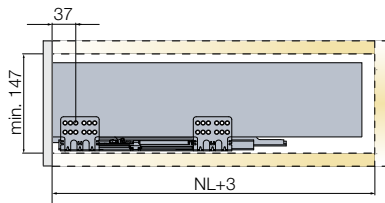

Drilling dimensions for the front panel

EasyFix attachment

Screw-in attachment

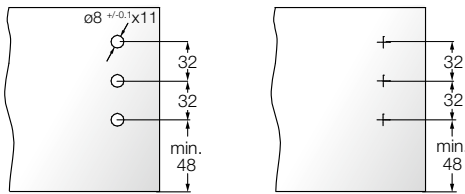

Mounting dimensions for the back panel

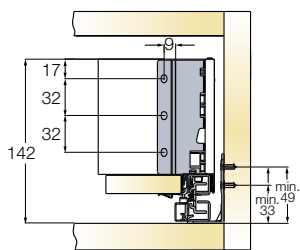

Installation dimensions for the front panel

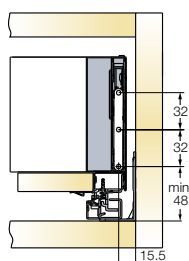

Drawer runner fixing positions

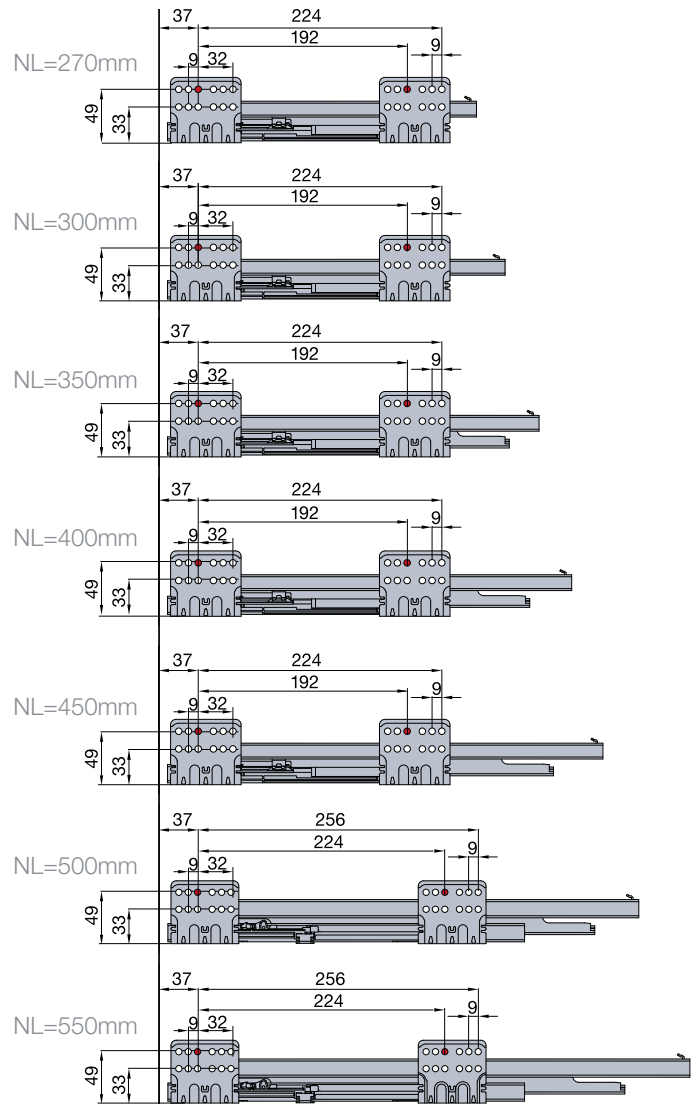
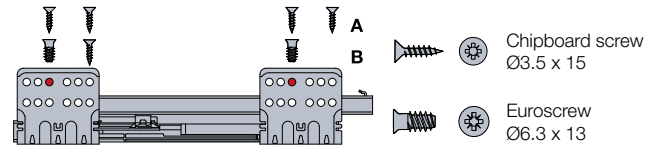

A trial mounting is always recommended.
For further information please contact your
Titus Group representative.

Tekform Slimline Tacto Drawer DW100 Touch Opening System

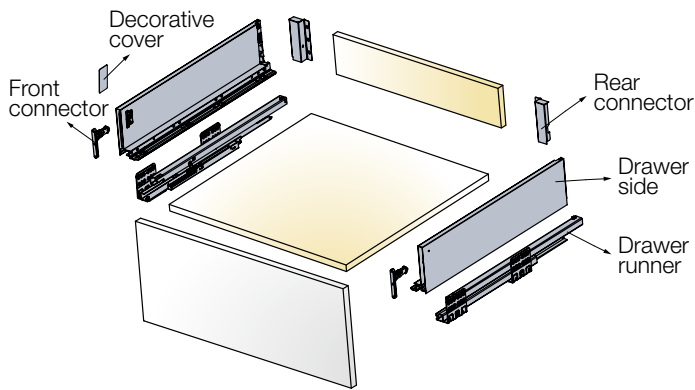
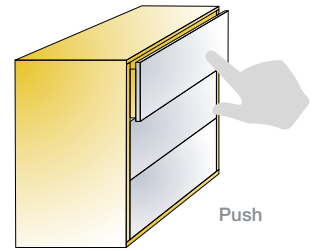

Cutting dimensions details

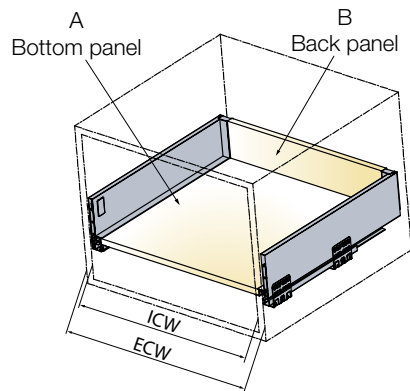



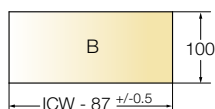
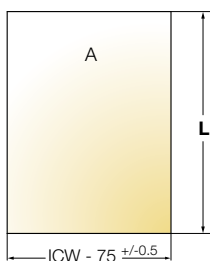



ECW: External cabinet width
ICW: Internal cabinet width
NL: Nominal length of drawer

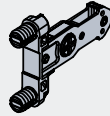
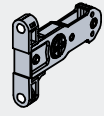

$L = NL - 10$
For further explanation → see page 3.8



4 sets

NL	with EasyFix front connector	with Screw-in front connector	White
Nominal length (mm)			
	Item number for a set	Item number for a set	
400	655-8U61 →	655-8F61 →	150
450	655-8U62 →	655-8F62 →	150
500	655-8U63 →	655-8F63 →	150
550	655-8U64 →	655-8F64 →	150
One set consists of			
Drawer sides			2 pcs
Drawer runners			2 pcs
*Front connectors			2 pcs
Rear connectors			2 pcs
Covers			2 pcs 2 pcs
Mounting instructions			1 pc/4 sets

Screws are not included

Touch opening



Tacto Slimline Mechanism
→ see page 3.47

- Drawer runner type
- Load capacity
- Minimum height per drawer required
- Wooden back panel thickness
- Wooden bottom panel thickness

full extension
40 kg
147mm
16mm
16mm

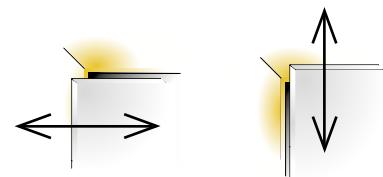

Side adjustment
+1/-1mm

Height adjustment
+2/-2mm

For further explanation → see page 3.10

i Works only with Tacto Slimline Mechanism
→ see page 3.47

Installation dimensions

Minimum space required for the cabinet

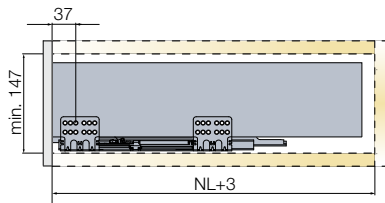

Drilling dimensions for the front panel

EasyFix attachment

Screw-in attachment

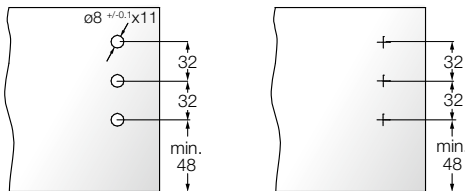

Mounting dimensions for the back panel

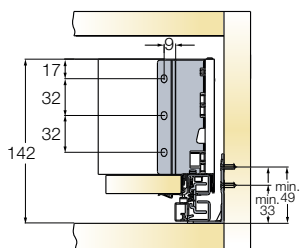

Installation dimensions for the front panel

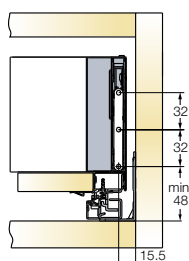

Drawer runner fixing positions

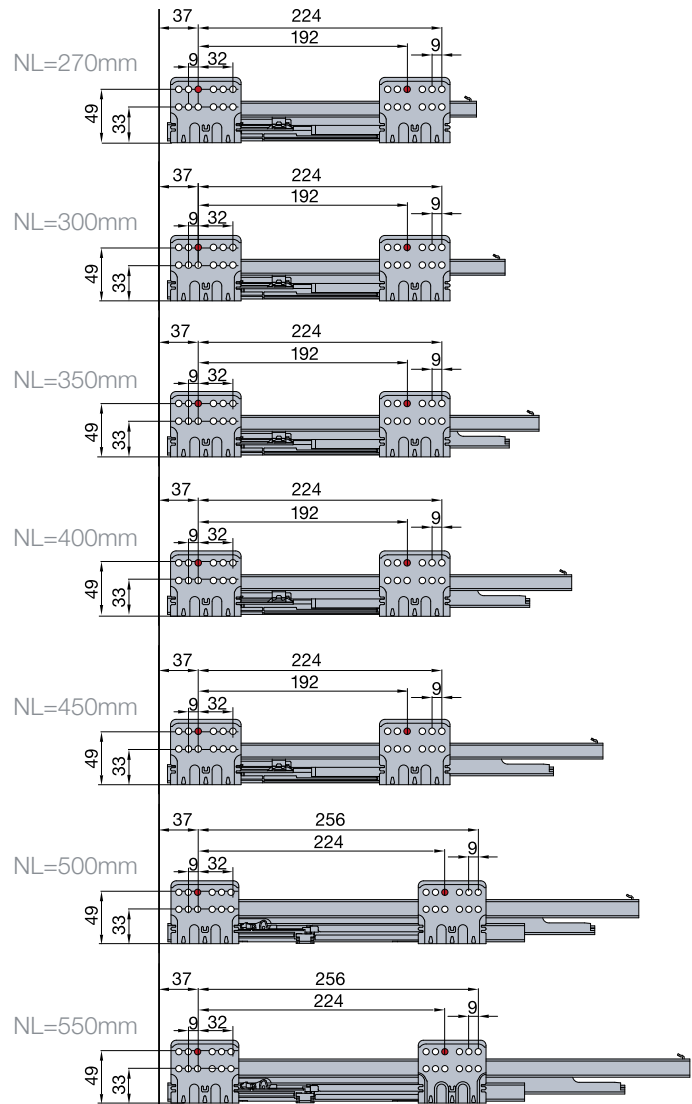
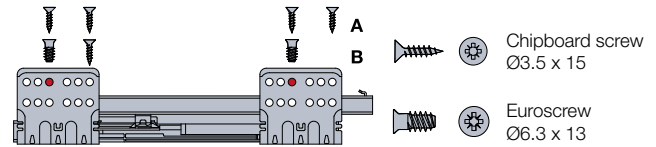

A trial mounting is always recommended.
For further information please contact your Titus Group representative.

Tekform Slimline Drawer DW145

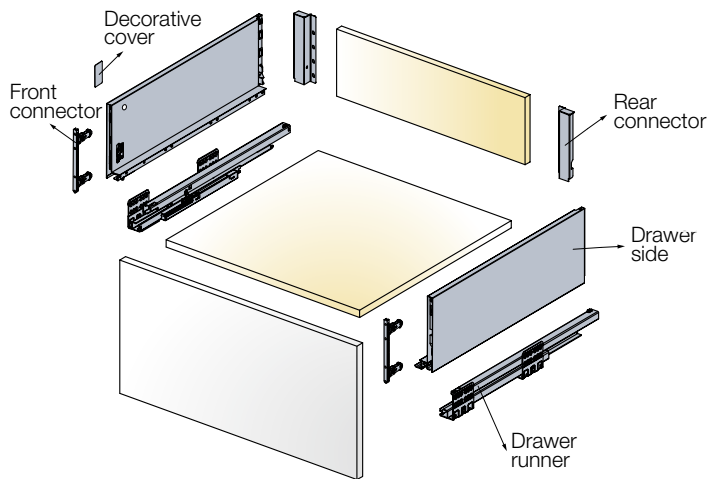
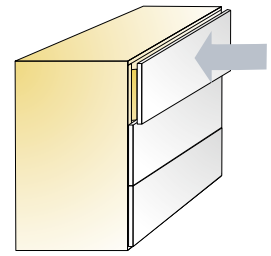

Cutting dimensions details

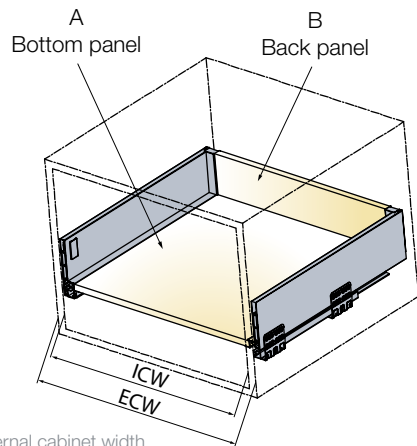

ECW: External cabinet width
 ICW: Internal cabinet width
 NL: Nominal length of drawer
 L_{st} : Length in case of steel back panel

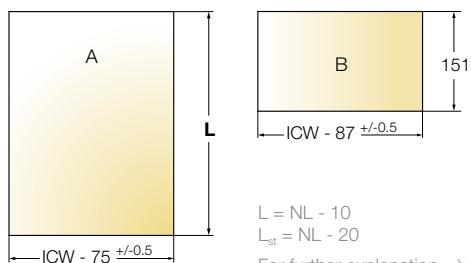

4 sets

NL	with EasyFix front connector	with Screw-in front connector		
Nominal length (mm)				
	Item number for a set	Item number for a set	White	Antracite grey + Glass
270	655-8V27 →	655-8G27 →	150	187
300	655-8V30 →	655-8G30 →	150	187
350	655-8V35 →	655-8G35 →	150	187
400	655-8V40 →	655-8G40 →	150	187
450	655-8V45 →	655-8G45 →	150	187
500	655-8V50 →	655-8G50 →	150	187
550	655-8V55 →	655-8G55 →	150	187
One set consists of				
Drawer sides				2 pcs
Drawer runners				2 pcs
*Front connectors				2 pcs
Rear connectors				2 pcs
Covers				2 pcs 2 pcs
Mounting instructions				1 pc/4 sets

Screws are not included

- Drawer runner type
- Load capacity
- Minimum height per drawer required
- Wooden back panel thickness
- Wooden bottom panel thickness

full extension
40 kg
198mm
16mm
16mm

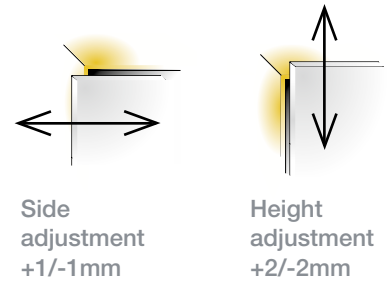

For further explanation → see page 3.10

Installation dimensions

Minimum space required for the cabinet

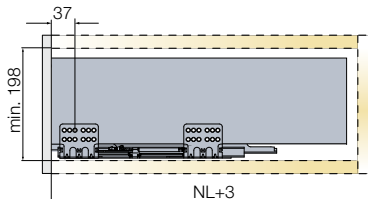

Drilling dimensions for the front panel

EasyFix attachment

Screw-in attachment

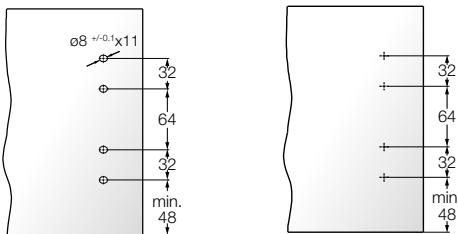

Mounting dimensions for the back panel

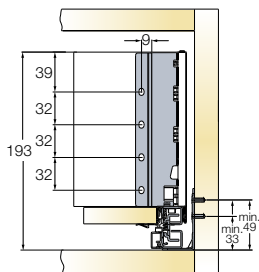

Installation dimensions for the front panel

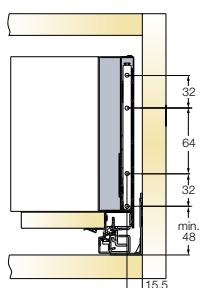

Drawer runner fixing positions

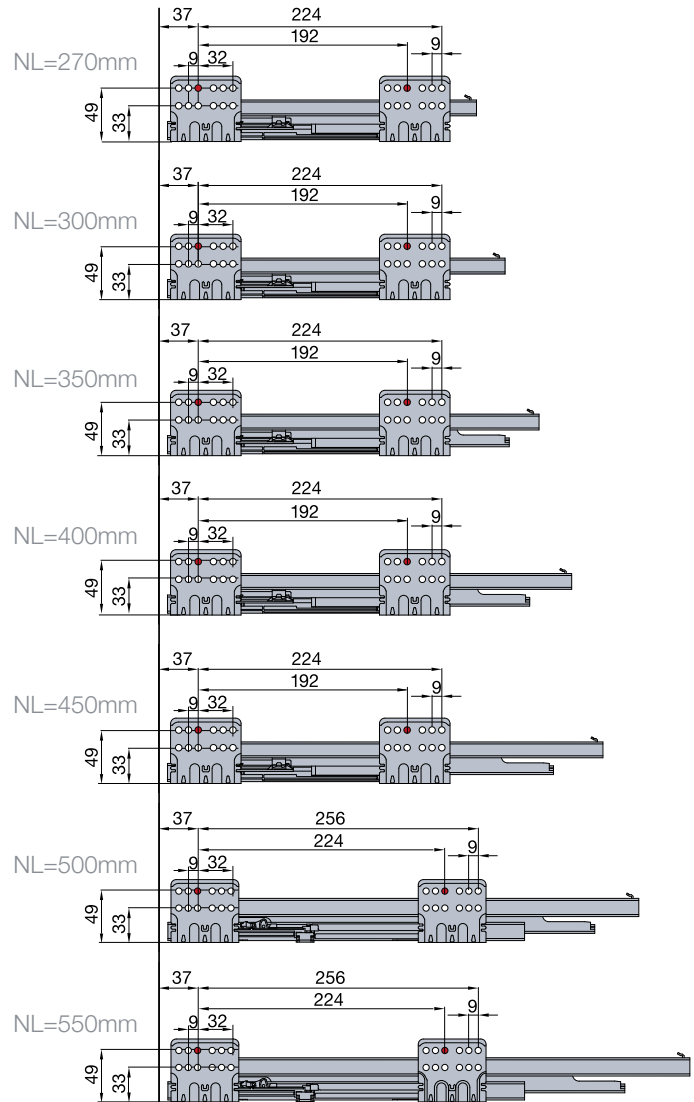
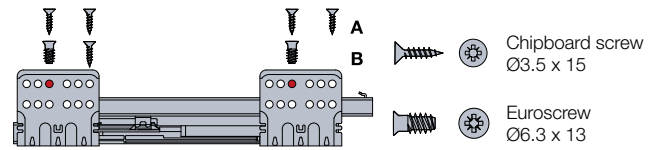

A trial mounting is always recommended.
For further information please contact your
Titus Group representative.

Tekform Slimline Tacto Drawer DW145 Touch Opening System

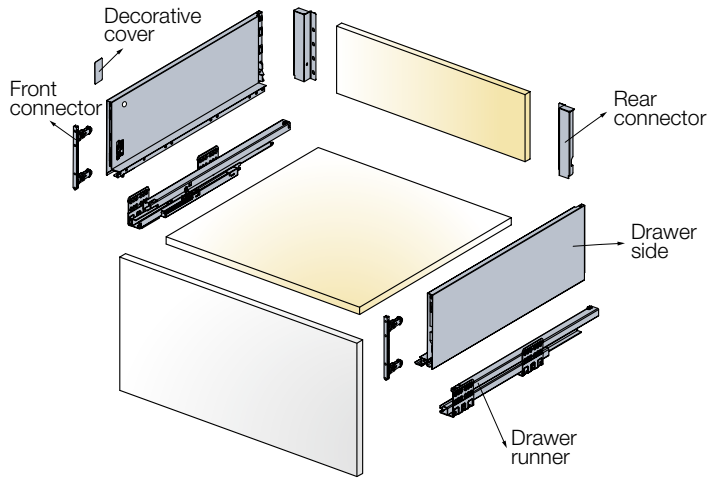
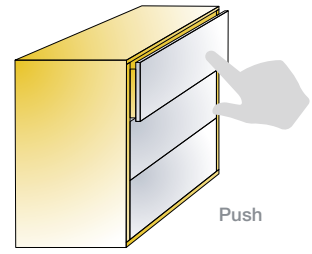

Cutting dimensions details

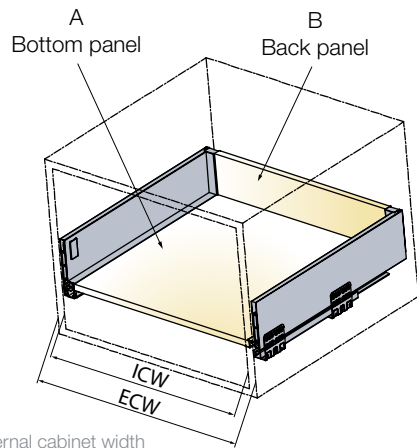

ECW: External cabinet width
ICW: Internal cabinet width
NL: Nominal length of drawer
L_{st}: Length in case of steel back panel

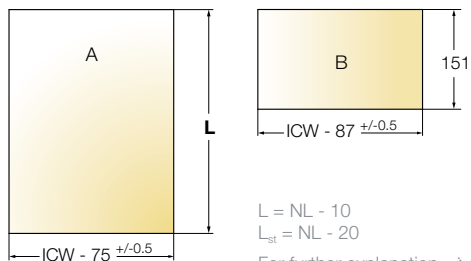

4 sets

NL	with EasyFix front connector	with Screw-in front connector	White
Nominal length (mm)			
	Item number for a set	Item number for a set	
400	655-8V61 →	655-8G61 →	150
450	655-8V62 →	655-8G62 →	150
500	655-8V63 →	655-8G63 →	150
550	655-8V64 →	655-8G64 →	150
One set consists of			
Drawer sides			2 pcs
Drawer runners			2 pcs
*Front connectors			2 pcs
Rear connectors			2 pcs
Covers			2 pcs 2 pcs
Mounting instructions			1 pc/4 sets

Screws are not included

Touch opening



Tacto Slimline Mechanism
→ see page 3.47

- Drawer runner type
- Load capacity
- Minimum height per drawer required
- Wooden back panel thickness
- Wooden bottom panel thickness

full extension
40 kg
198mm
16mm
16mm

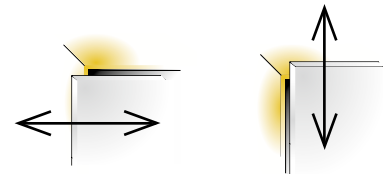

Side adjustment
+1/-1mm

Height adjustment
+2/-2mm

For further explanation → see page 3.10

i Works only with Tacto Slimline Mechanism
→ see page 3.47

Installation dimensions

Minimum space required for the cabinet

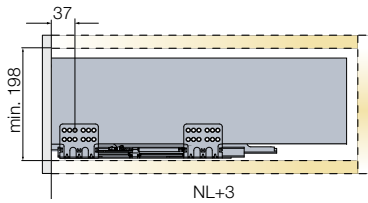

Drilling dimensions for the front panel

EasyFix attachment

Screw-in attachment

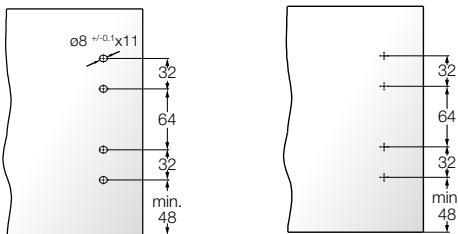

Mounting dimensions for the back panel

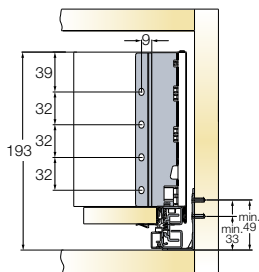

Installation dimensions for the front panel

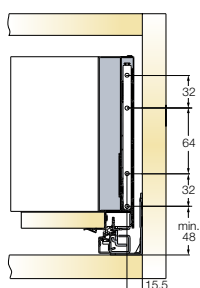

Drawer runner fixing positions

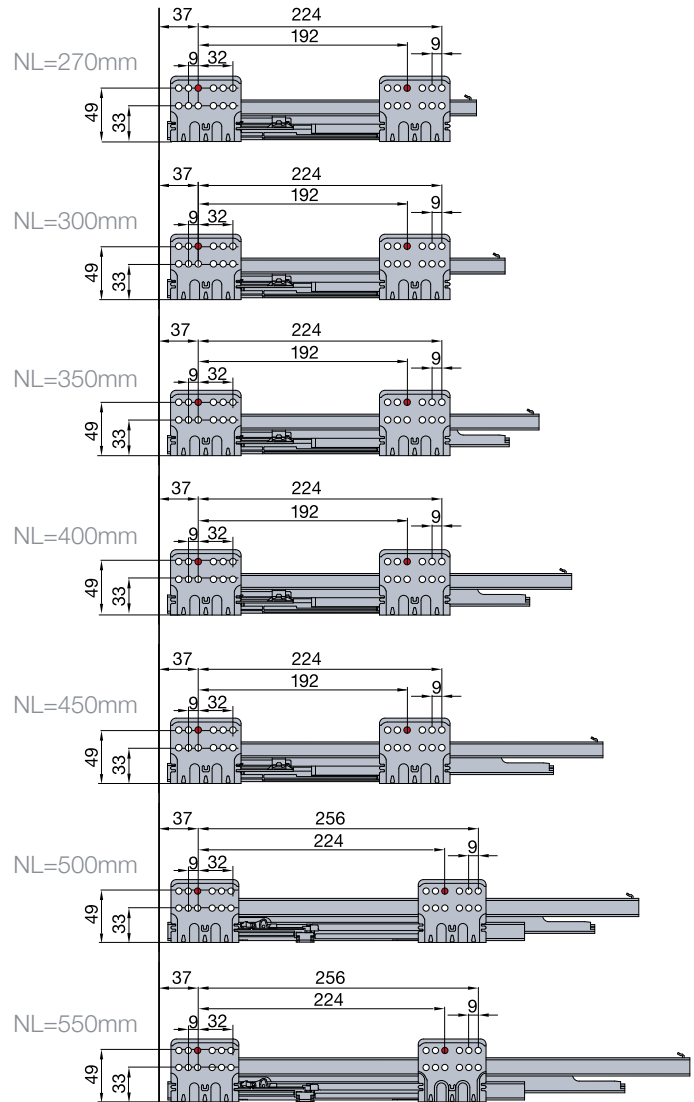
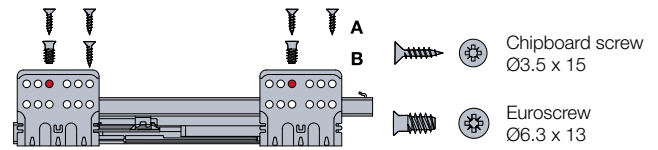

A trial mounting is always recommended.
For further information please contact your Titus Group representative.

Tekform Slimline Drawer DW145 With Glass Sides

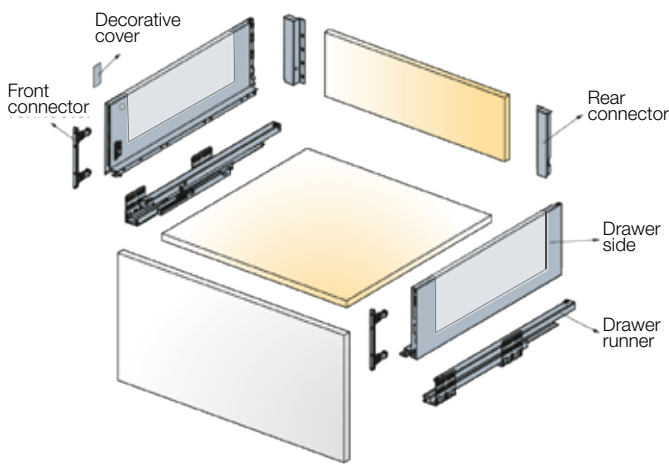
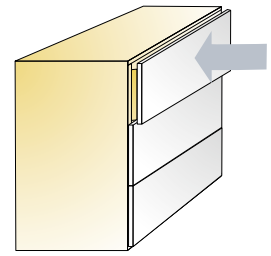

Cutting dimensions details

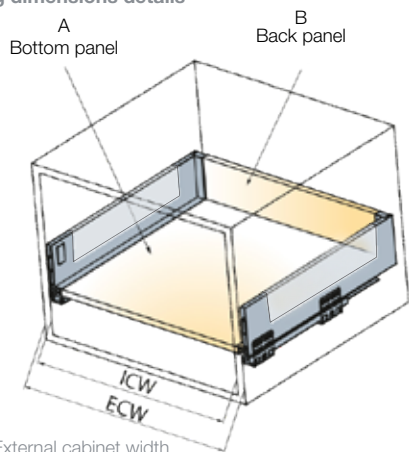

ECW: External cabinet width
ICW: Internal cabinet width
NL: Nominal length of drawer
L_{st}: Length in case of steel back panel

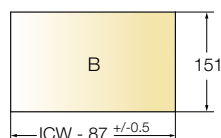
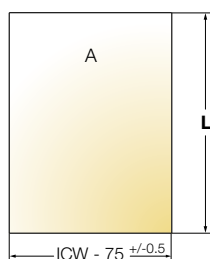





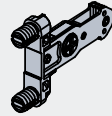
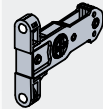

$$L = NL - 10$$

$$L_{st} = NL - 20$$

For further explanation → see page 3.8

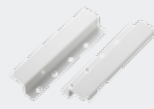
 4 sets

NL	with EasyFix front connector	with Screw-in front connector		
			White + Glass	Antracite grey + Glass
Nominal length (mm)	Item number for a set	Item number for a set		
400	655-7S40 →	655-7W40 →	152	187
450	655-7S45 →	655-7W45 →	152	187
500	655-7S50 →	655-7W50 →	152	187
One set consists of				
	Drawer sides		2 pcs	
	Drawer runners		2 pcs	
	Front connectors		2 pcs	
	Rear connectors		2 pcs	
	Covers		2 pcs	
	Mounting instructions		1 pc/4 sets	

Screws are not included

- Drawer runner type
- Load capacity
- Minimum height space required
- Wooden back panel thickness
- Wooden bottom panel thickness
- Tempered glass sides

Full extension
40kg
198mm
16mm
16mm
8mm, transparent

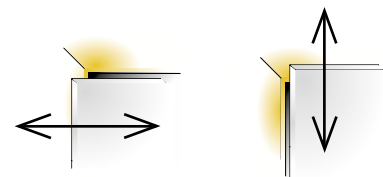

Side adjustment
+1/-1mm

Height adjustment
+2/-2mm

For further explanation → see page 3.10

Installation dimensions

Minimum space required for the cabinet

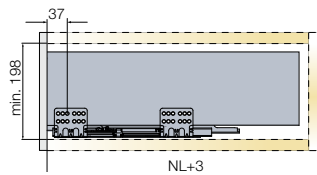

Drilling dimensions for the front panel

EasyFix attachment

Screw-in attachment

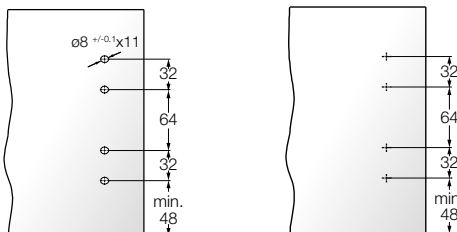

Mounting dimensions for the back panel

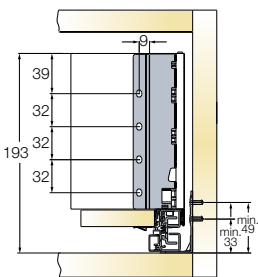

Installation dimensions for the front panel

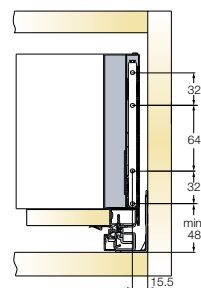

Drawer runner fixing positions

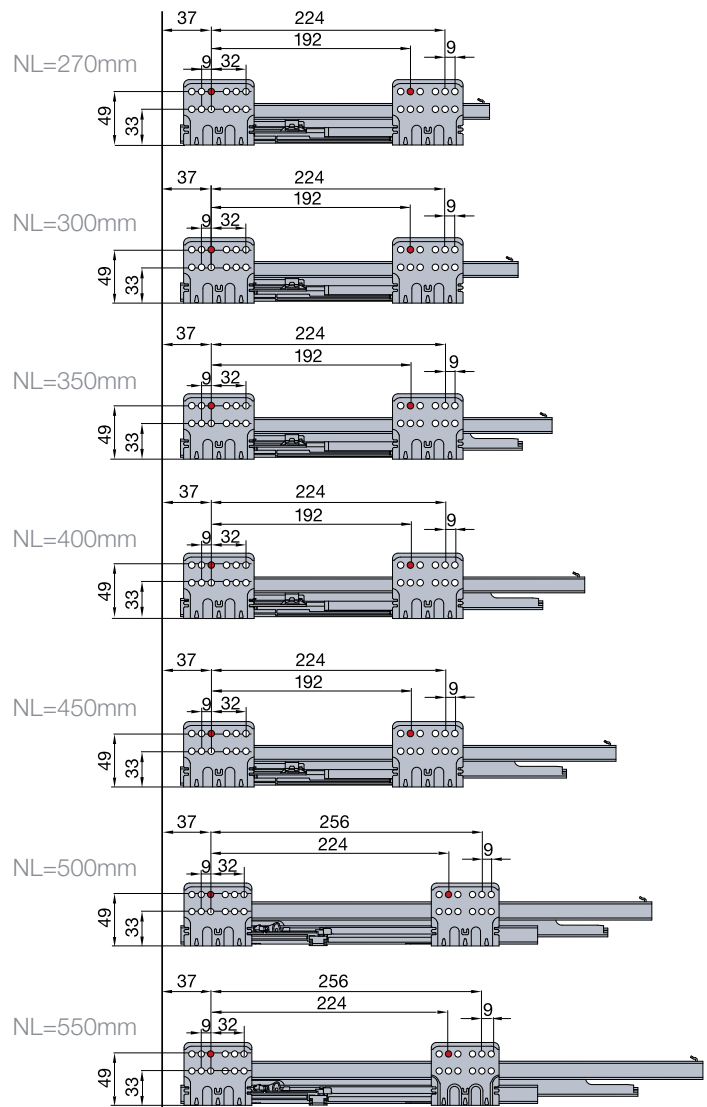
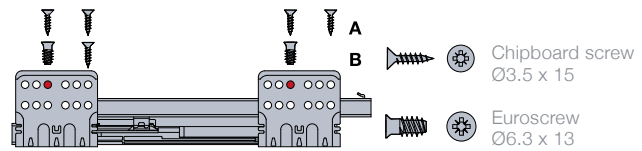

A trial mounting is always recommended.
For further information please contact your Titus Group representative.

Tekform Slimline Drawer DW182

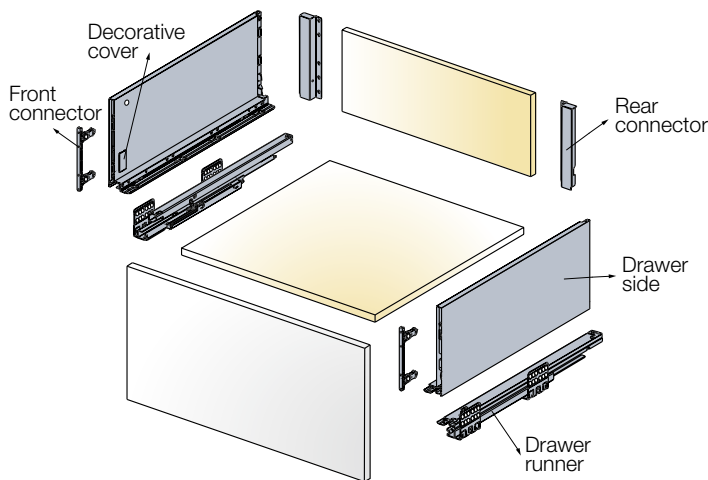
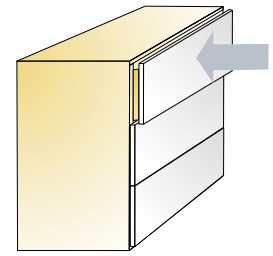

Cutting dimensions details

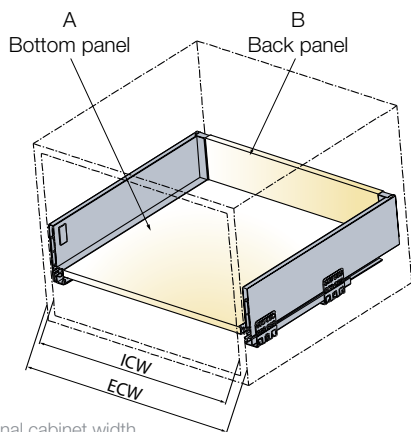

ECW: External cabinet width
ICW: Internal cabinet width
NL: Nominal length of drawer
L_{st}: Length in case of steel back panel

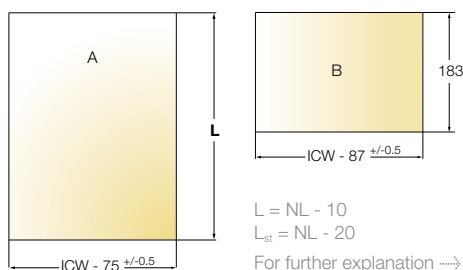

NL	with EasyFix front connector	with Screw-in front connector		
Nominal length (mm)			White	Antracite grey
	Item number for a set	Item number for a set		

270	655-8Z27 →	655-8H27 →	150	185
300	655-8Z30 →	655-8H30 →	150	185
350	655-8Z35 →	655-8H35 →	150	185
400	655-8Z40 →	655-8H40 →	150	185
450	655-8Z45 →	655-8H45 →	150	185
500	655-8Z50 →	655-8H50 →	150	185
550	655-8Z55 →	655-8H55 →	150	185

One set consists of				
Drawer sides		2 pcs		
Drawer runners		2 pcs		
*Front connectors		2 pcs		
Rear connectors		2 pcs		
Covers		2 pcs		
		2 pcs		
Mounting instructions		1 pc/4 sets		

Screws are not included

- Drawer runner type
- Load capacity
- Minimum height per drawer required
- Wooden back panel thickness
- Wooden bottom panel thickness

full extension
40kg
230mm
16mm
16mm

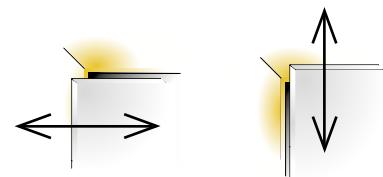

Side adjustment
+1/-1mm

Height adjustment
+2/-2mm

For further explanation → see page 3.10

Installation dimensions

Drawer runner fixing positions

Minimum space required for the cabinet

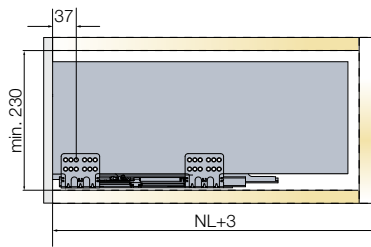

Drilling dimensions for the front panel

EasyFix attachment

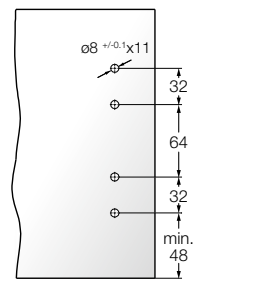

Screw-in attachment

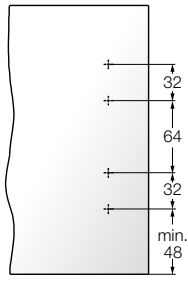

Mounting dimensions for the back panel

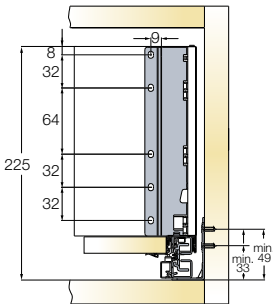

Installation dimensions for the front panel

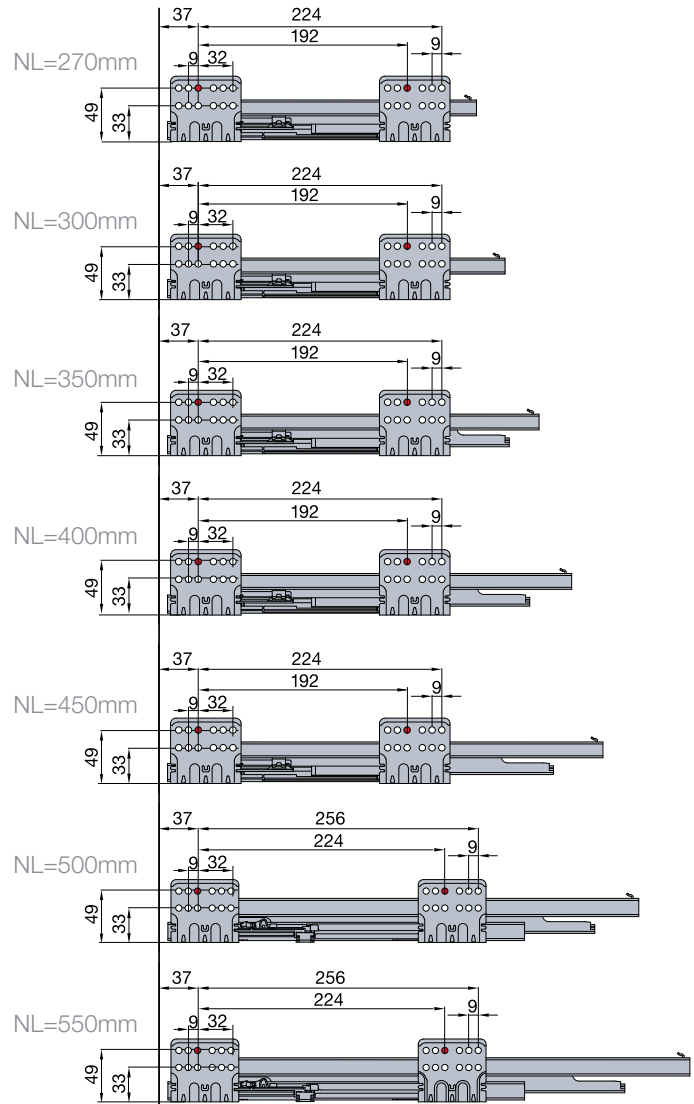
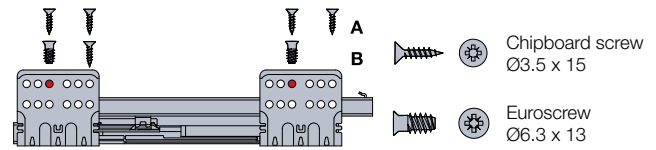
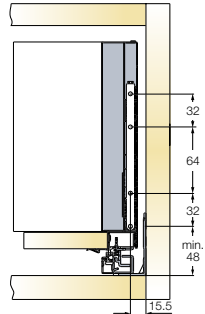

A trial mounting is always recommended.
For further information please contact your
Titus Group representative.

Tekform Slimline Tacto Drawer DW182

Touch Opening System

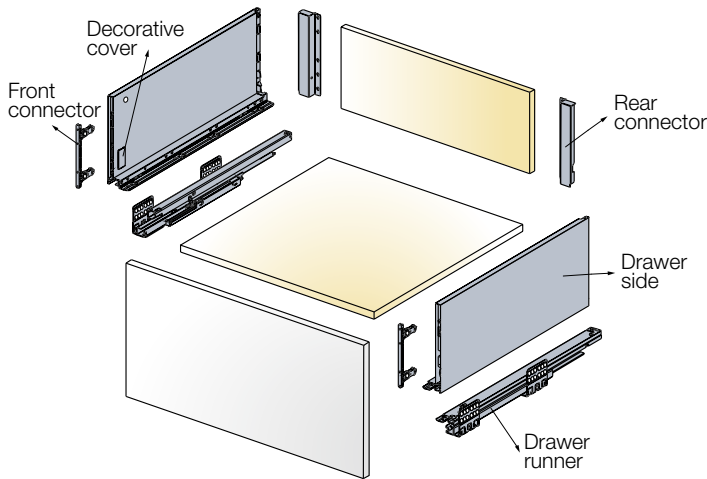
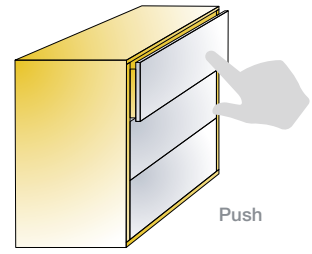

Cutting dimensions details

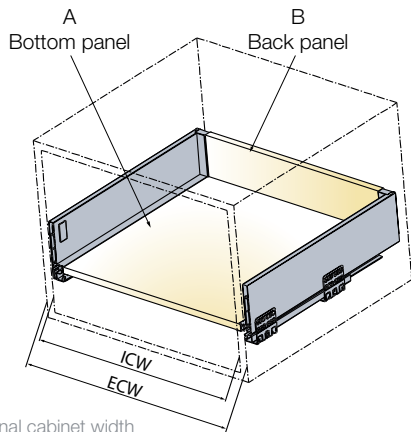

ECW: External cabinet width
 ICW: Internal cabinet width
 NL: Nominal length of drawer
 L_{st}: Length in case of steel back panel

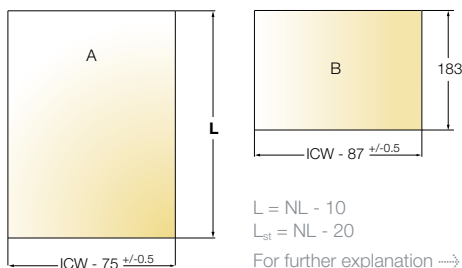

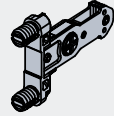
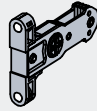
NL	with EasyFix front connector	with Screw-in front connector	White
Nominal length (mm)			
	Item number for a set	Item number for a set	
400	655-8Z61 →	655-8H61 →	150
450	655-8Z62 →	655-8H62 →	150
500	655-8Z63 →	655-8H63 →	150
550	655-8Z64 →	655-8H64 →	150

One set consists of

Drawer sides  2 pcs

Drawer runners  2 pcs

*Front connectors  2 pcs

Rear connectors  2 pcs

Covers  2 pcs

2 pcs

Mounting instructions  1 pc/4 sets

Screws are not included

Touch opening



Tacto Slimline Mechanism
 → see page 3.47

- Drawer runner type
- Load capacity
- Minimum height per drawer required
- Wooden back panel thickness
- Wooden bottom panel thickness

full extension
40kg
230mm
16mm
16mm

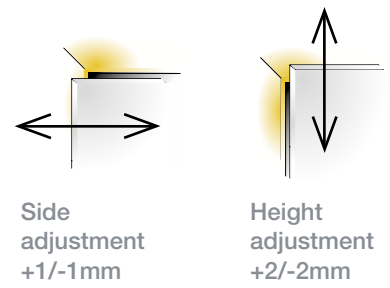

For further explanation → see page 3.10

i Works only with Tacto Slimline Mechanism
→ see page 3.47

Installation dimensions

Drawer runner fixing positions

Minimum space required for the cabinet

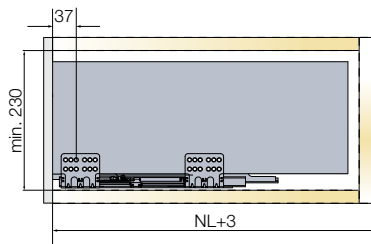

Drilling dimensions for the front panel

EasyFix attachment

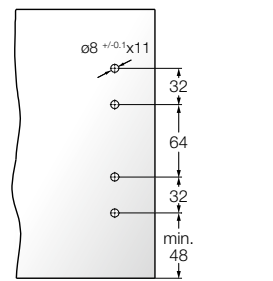

Screw-in attachment

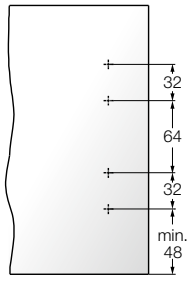

Mounting dimensions for the back panel

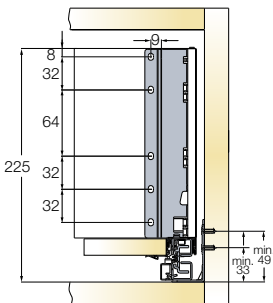

Installation dimensions for the front panel

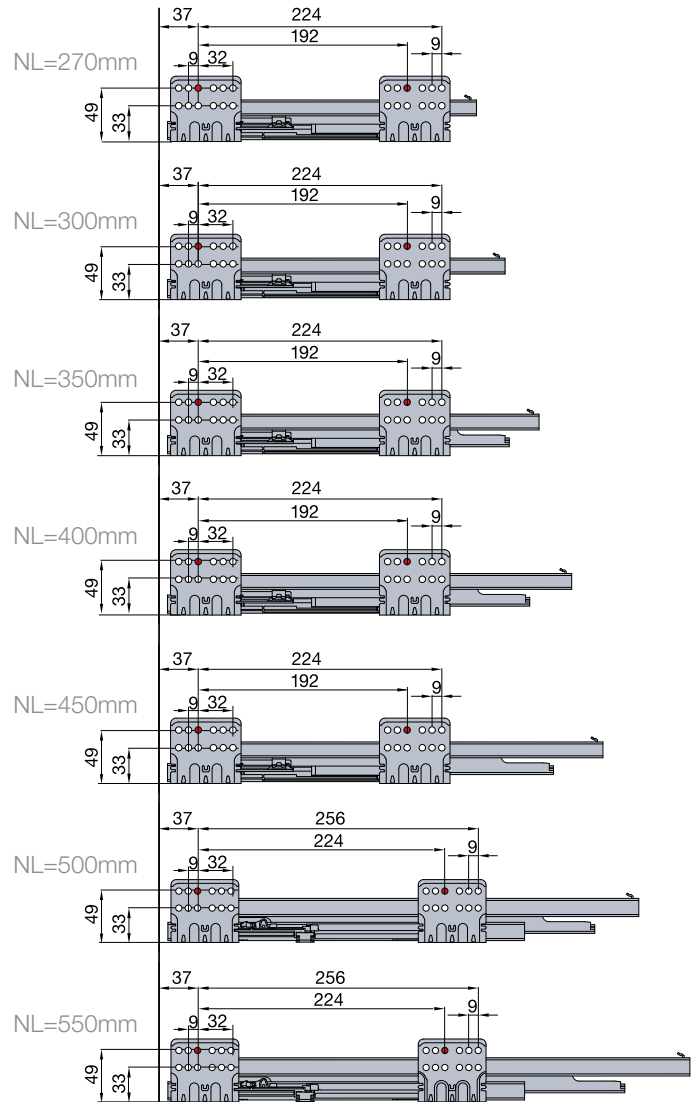
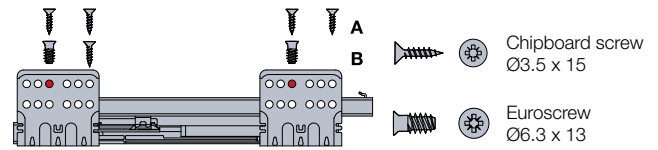
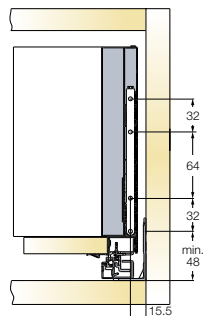

A trial mounting is always recommended.
For further information please contact your Titus Group representative.

Tekform Slimline Drawer DW182 With Glass Sides

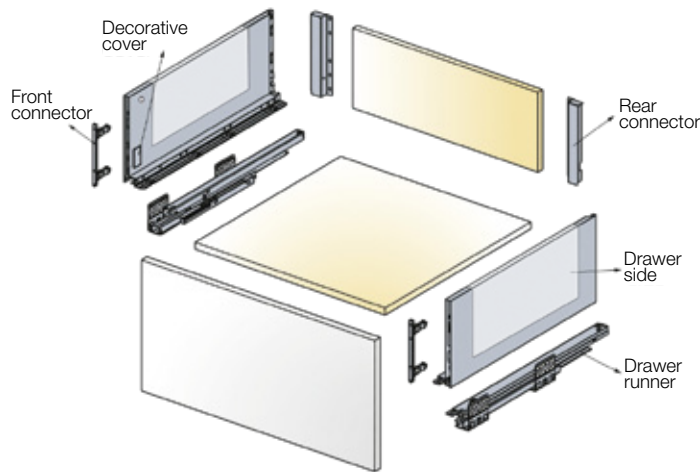
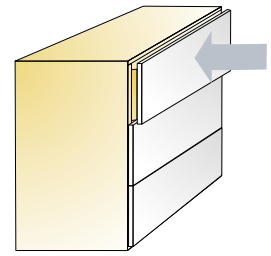

Cutting dimensions details

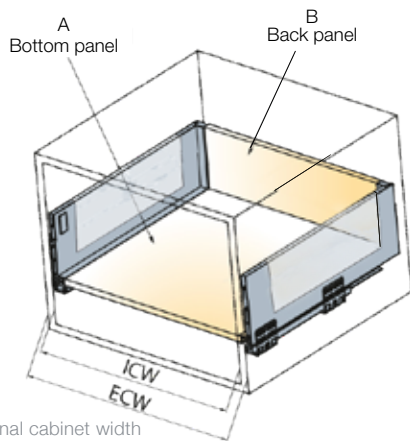



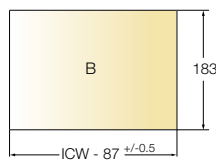
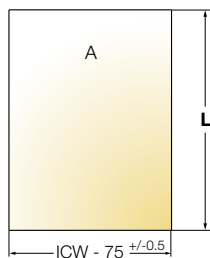



ECW: External cabinet width
ICW: Internal cabinet width
NL: Nominal length of drawer
L_{st}: Length in case of steel back panel

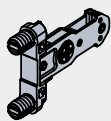
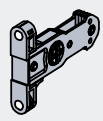

$L = NL - 10$
 $L_{st} = NL - 20$

For further explanation → see page 3.8

NL	with EasyFix front connector	with Screw-in front connector		
			White + Glass	Antracite grey + Glass
Nominal length (mm)	Item number for a set	Item number for a set		
400	655-7T40 →	655-7X40 →	152	187
450	655-7T45 →	655-7X45 →	152	187
500	655-7T50 →	655-7X50 →	152	187
One set consists of				
	Drawer sides		2 pcs	
	Drawer runners		2 pcs	
	Front connectors		2 pcs	
	Rear connectors		2 pcs	
	Covers		2 pcs 2 pcs	
	Mounting instructions		1 pc/4 sets	

 4 sets

Screws are not included

- Drawer runner type
- Load capacity
- Minimum height space required
- Wooden back panel thickness
- Wooden bottom panel thickness
- Tempered glass sides

Full extension
40kg
230mm
16mm
16mm
8mm, transparent

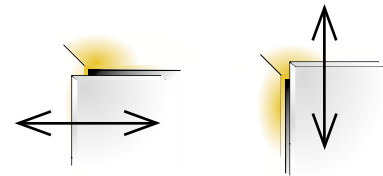

Side adjustment
+1/-1mm

Height adjustment
+2/-2mm

For further explanation → see page 3.10

Installation dimensions

Drawer runner fixing positions

Minimum space required for the cabinet

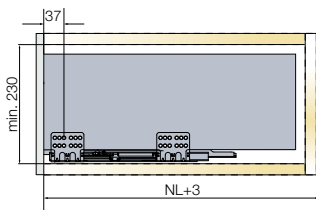

Drilling dimensions for the front panel

EasyFix attachment

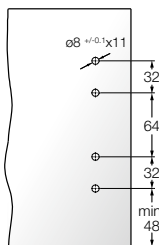

Screw-in attachment

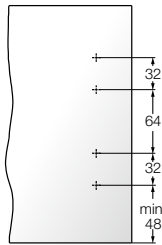

Mounting dimensions for the back panel

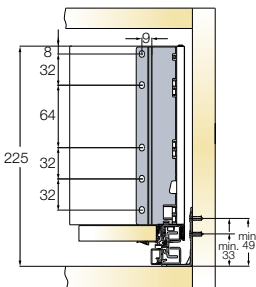

Installation dimensions for the front panel

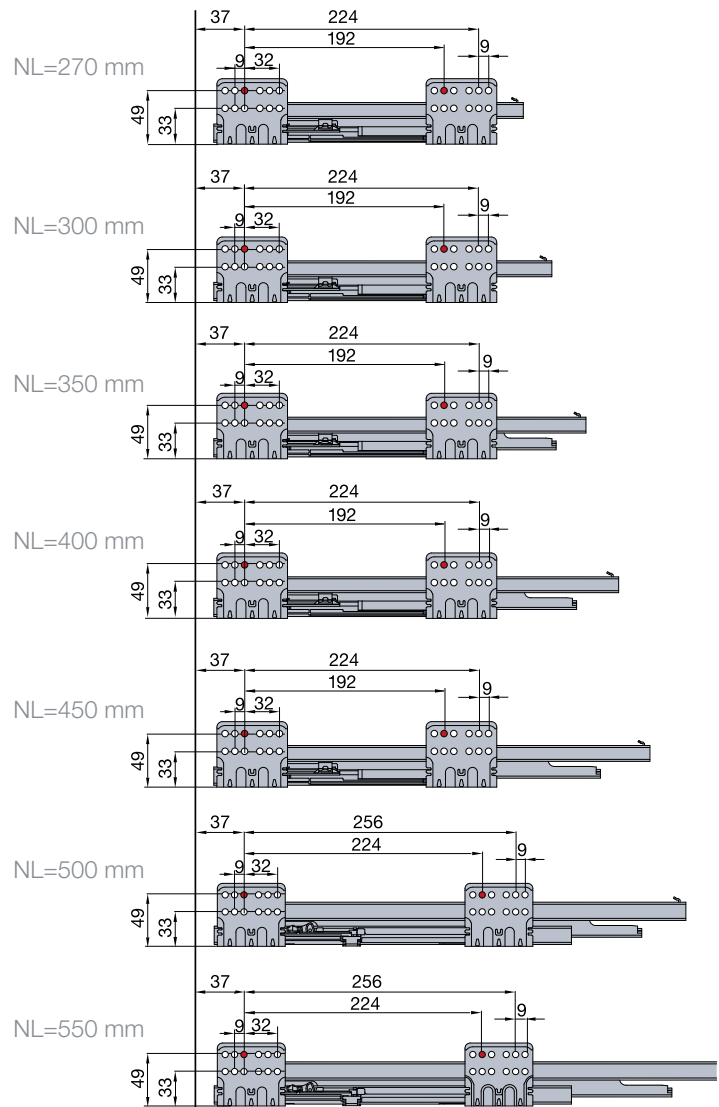
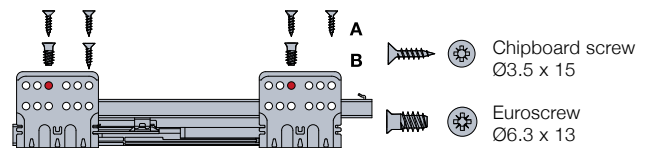
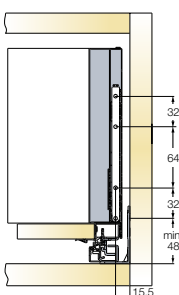

A trial mounting is always recommended.
For further information please contact your
Titus Group representative.

Inner Drawer Front for Tekform Slimline Drawer DW70

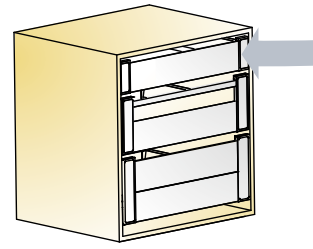

Front panel



Cutting dimension L = ICW-100
ICW → see page 3.28



20 pcs

Made of aluminium

Front bracket



50 sets

Made of aluminium and plastic

ECW	External cabinet width	Item number	White	Antracite grey
1200	655-8064 →	511	515	
		655-8065 →	150	185

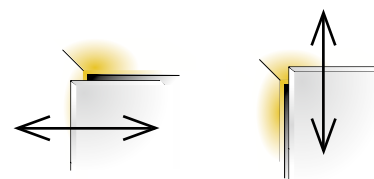
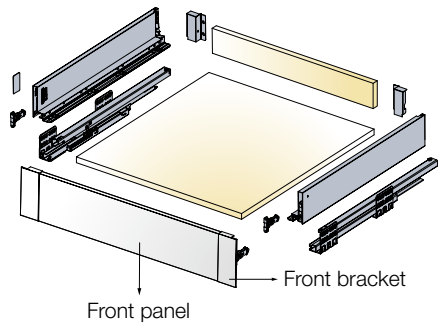

Side adjustment
+1/-1mm

Height adjustment
+2/-2mm

For further explanation → see page 3.10

Installation dimensions

Minimum space required for the cabinet

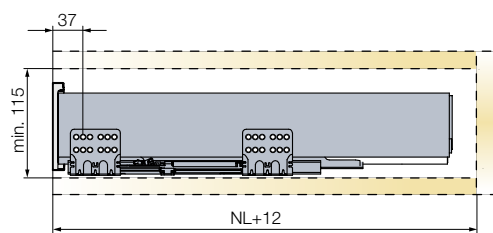

Cutting dimensions details

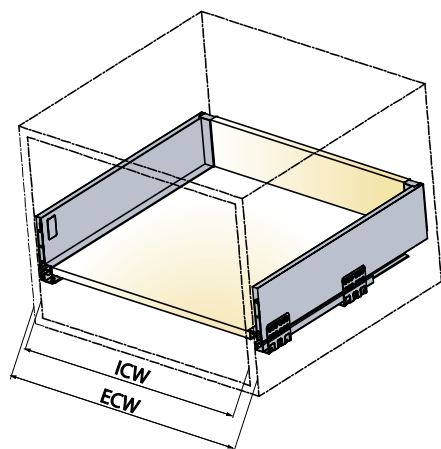

ECW: External cabinet width
ICW: Internal cabinet width
NL: Nominal length of drawer

Drawer runner fixing positions

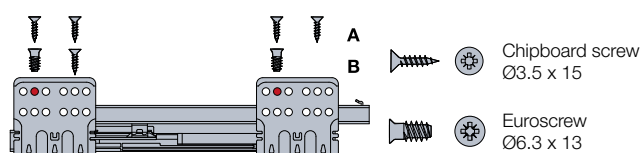

⚠ Use the second hole for runner fixing.

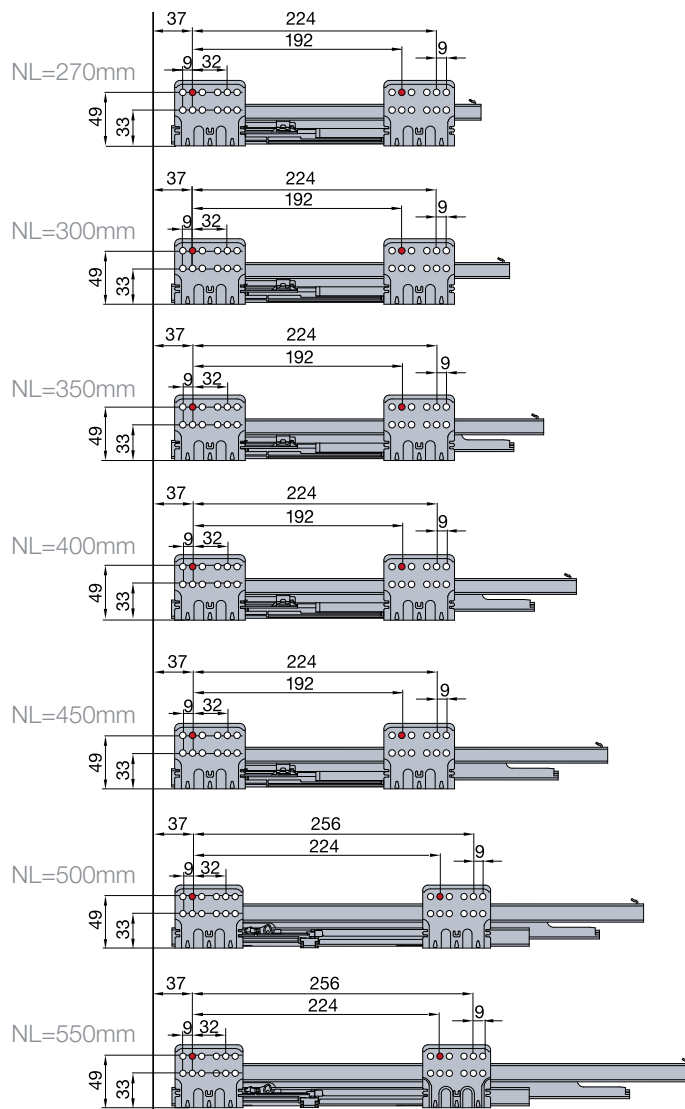

Inner Drawer Front for Tekform Slimline Drawer DW70 with Glass

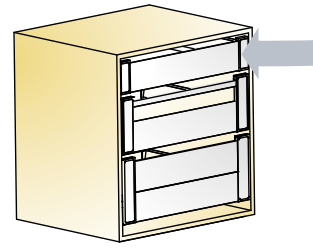

Front panel

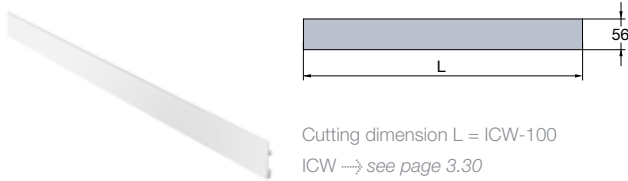

20 pcs

Made of aluminium

Low glass

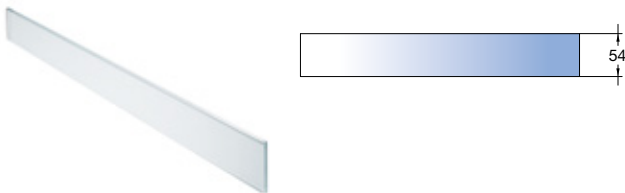

10 pcs

20 pcs (655-8295, 655-8300,
655-8296, 655-8301)

Made of glass

Front bracket



50 sets

Made of aluminium and plastic

ECW	Cabinet side Thickness=16mm	Cabinet side Thickness=18mm			
External cabinet width			White	Antracite grey	Transparent glass
Item number	Item number				
1200	655-8085 →		511	515	
600	655-8295 →	655-8300 →			392
800	655-8296 →	655-8301 →			392
900	655-8297 →	655-8302 →			392
	655-8305 →		150	185	

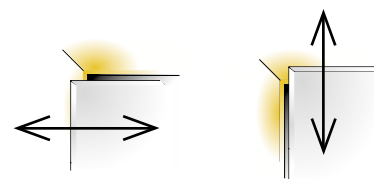
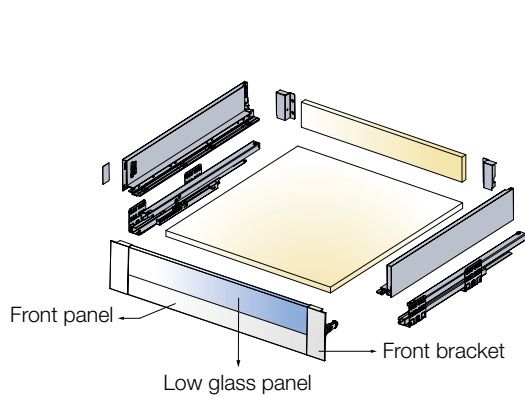

Side adjustment
+1/-1mm

Height adjustment
+2/-2mm

For further explanation → see page 3.10

Installation dimensions

Minimum space required for the cabinet

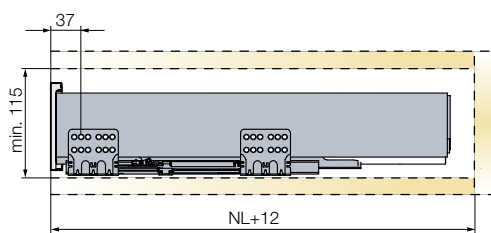

Cutting dimensions details

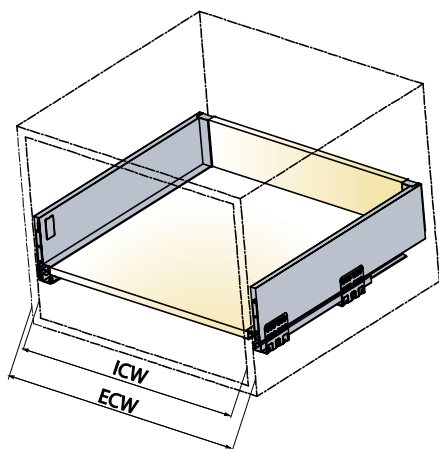

ECW: External cabinet width
ICW: Internal cabinet width
NL: Nominal length of drawer

Drawer runner fixing positions

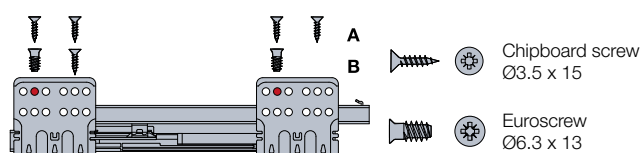

⚠ Use the second hole for runner fixing.

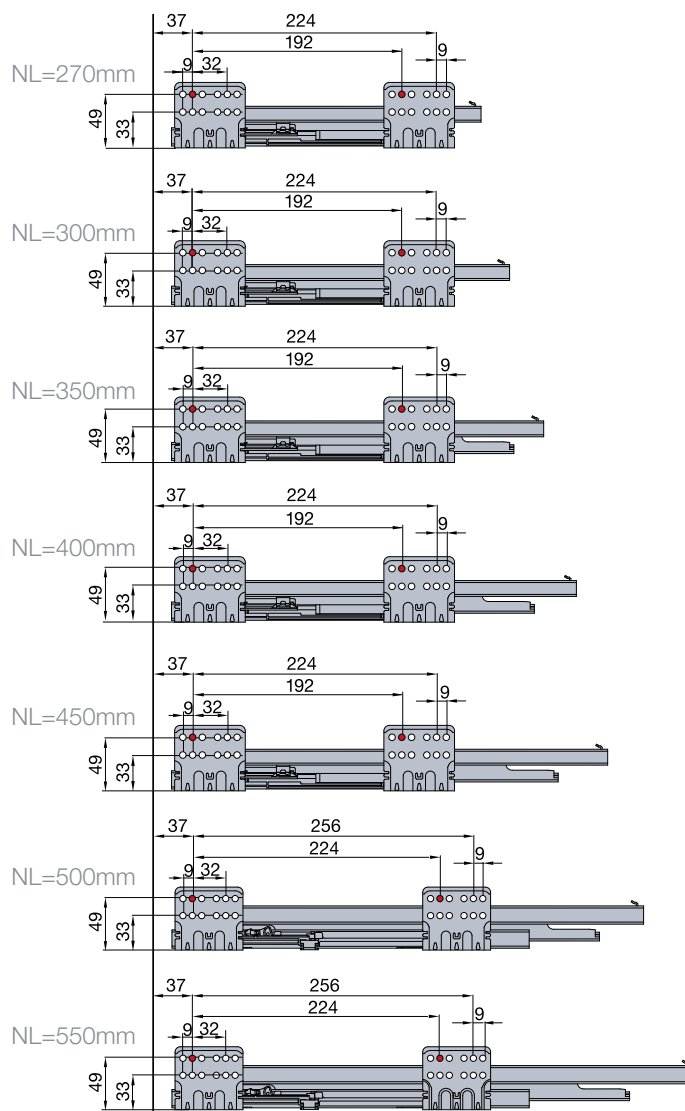

Inner Drawer Front for Tekform Slimline Drawer DW145 with Bar

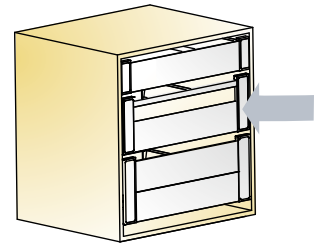

Front bar

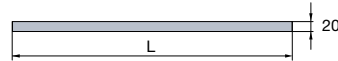

Cutting dimension L = ICW-88
ICW → see page 3.32

 50 pcs

Made of aluminium

Front panel

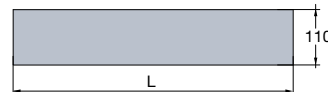

Cutting dimension L = ICW-100
ICW → see page 3.32

 20 pcs

Made of aluminium

Front bracket



 20 pcs

Made of aluminium and plastic

ECW	External cabinet width	Item number	White	Antracite grey
1200	655-8090 →	511	515	
1200	655-8064 →	511	515	
	655-8101 →	350	385	

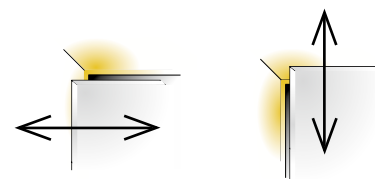
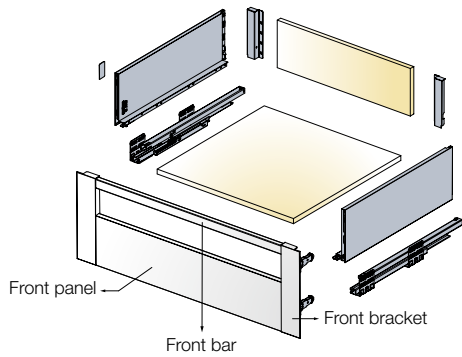

Side adjustment
+1/-1mm

Height adjustment
+2/-2mm

For further explanation → see page 3.10

Installation dimensions

Minimum space required for the cabinet

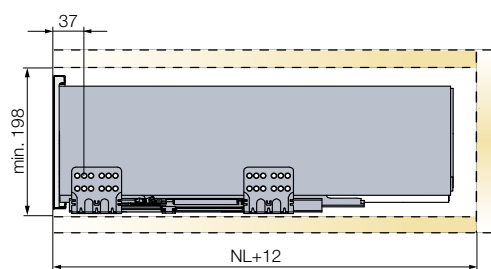

Drawer runner fixing positions

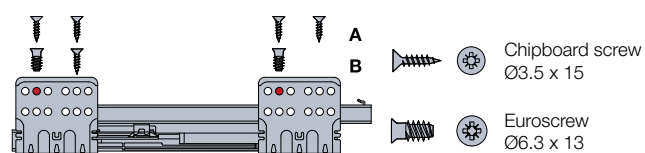

⚠ Use the second hole for runner fixing.

Cutting dimensions details

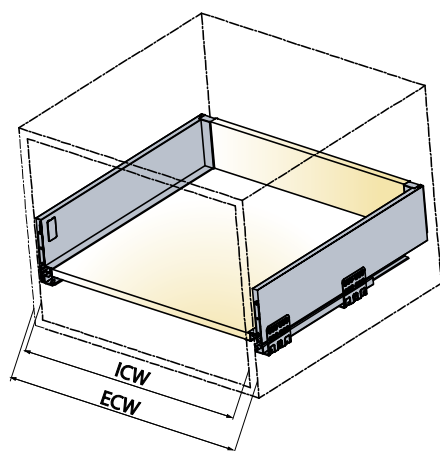

ECW: External cabinet width
ICW: Internal cabinet width
NL: Nominal length of drawer

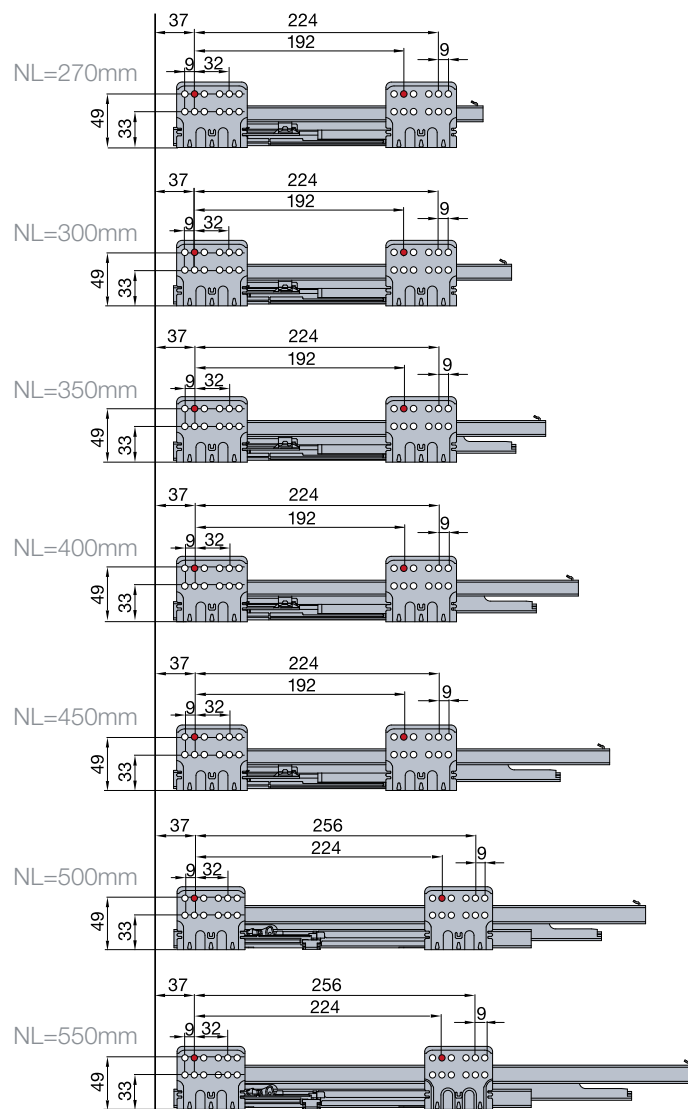

Inner Drawer Front for Tekform Slimline Drawer DW145 with High Glass

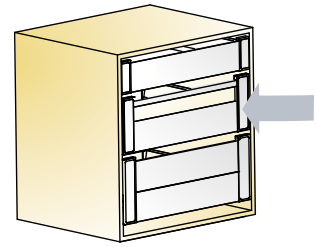

Front panel

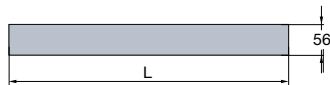

Cutting dimension L = ICW-100
ICW → see page 3.34

 20 pcs

Made of aluminium

Front glass panel - high



 5 pcs
10 pcs (655-8220, 655-8096,
655-8221, 655-8097)

Made of glass

Front bracket



 20 sets

Made of aluminium and plastic

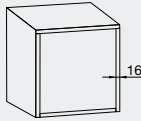
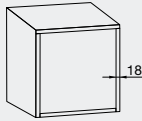
ECW	Cabinet side Thickness=16mm	Cabinet side Thickness=18mm			
External cabinet width			White	Antracite grey	Transparent glass
Item number	Item number				
1200	655-8085 →		511	515	
600	655-8220 →	655-8096 →			392
800	655-8221 →	655-8097 →			392
900	655-8222 →	655-8098 →			392
	655-8103 →		350	385	

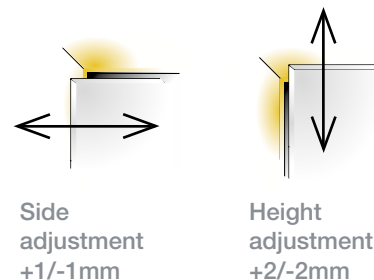
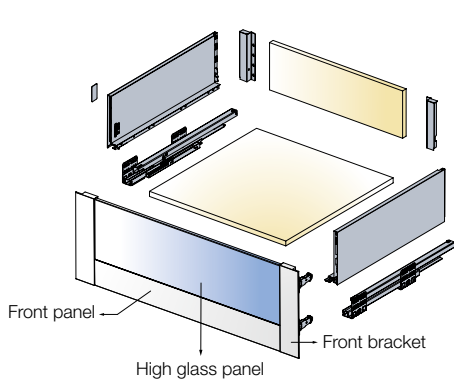

For further explanation → see page 3.10

Installation dimensions

Minimum space required for the cabinet

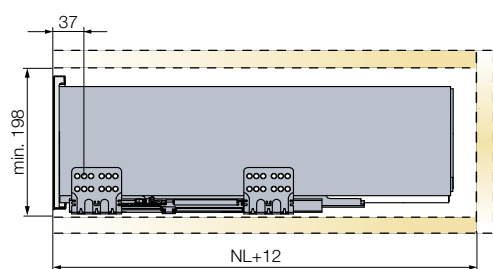

Drawer runner fixing positions

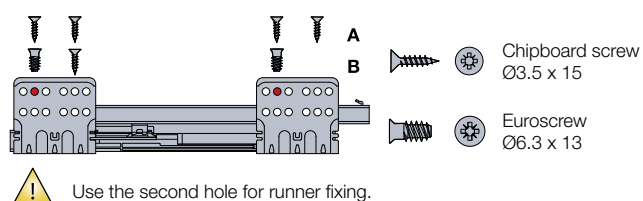

Cutting dimensions details

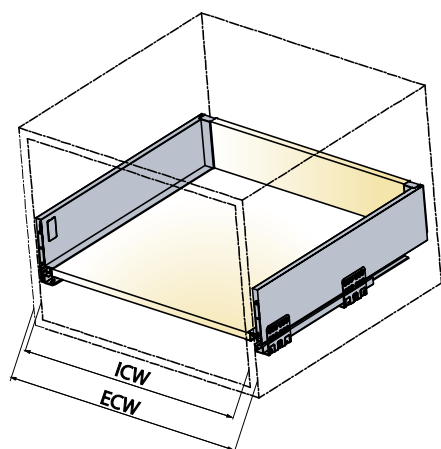

ECW: External cabinet width
ICW: Internal cabinet width
NL: Nominal length of drawer

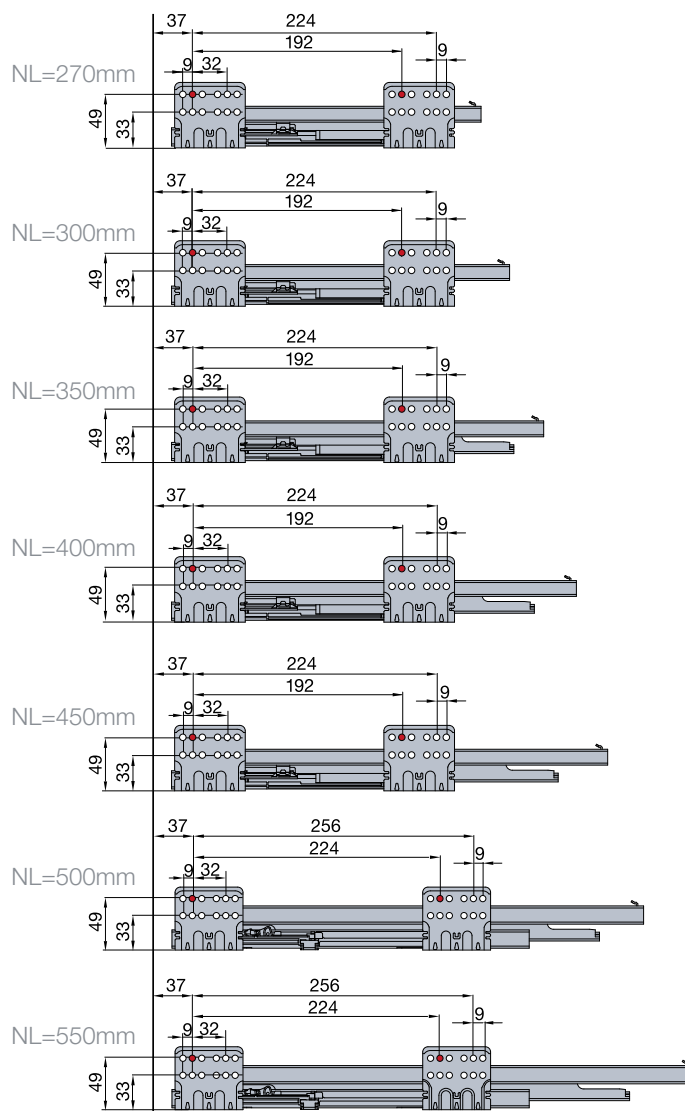

Inner Drawer Front for Tekform Slimline Drawer DW182 with Bar

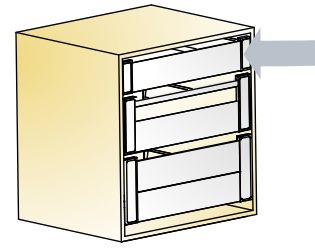

Front bar

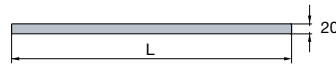

Cutting dimension L = ICW-88
ICW → see page 3.36

 50 pcs

Made of aluminium and plastic

Front panel

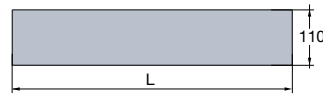

Cutting dimension L = ICW-100
ICW → see page 3.36

 20 pcs

Made of aluminium

Front bracket



 20 sets

Made of aluminium and plastic

ECW	External cabinet width	Item number	White	Antracite grey
	1200	655-8090 →	511	515
	1200	655-8064 →	511	515
		655-8170 →	350	385

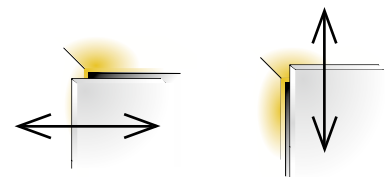
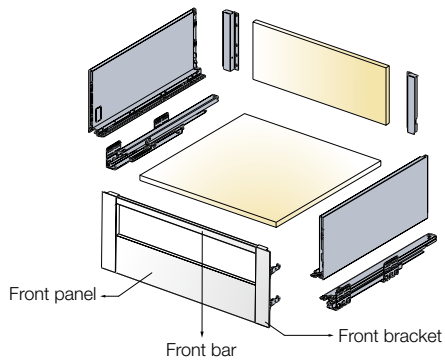

Side adjustment
+1/-1mm

Height adjustment
+2/-2mm

For further explanation → see page 3.10

Installation dimensions

Drawer runner fixing positions

Minimum space required for the cabinet

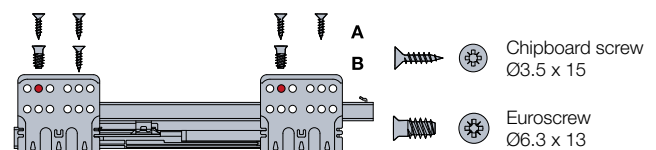
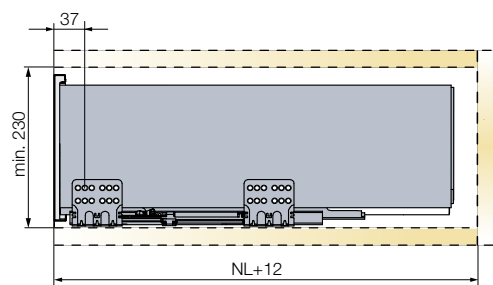

⚠ Use the second hole for runner fixing.

Cutting dimensions details

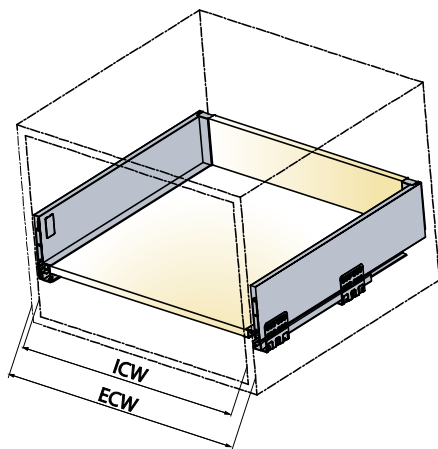

ECW: External cabinet width
ICW: Internal cabinet width
NL: Nominal length of drawer

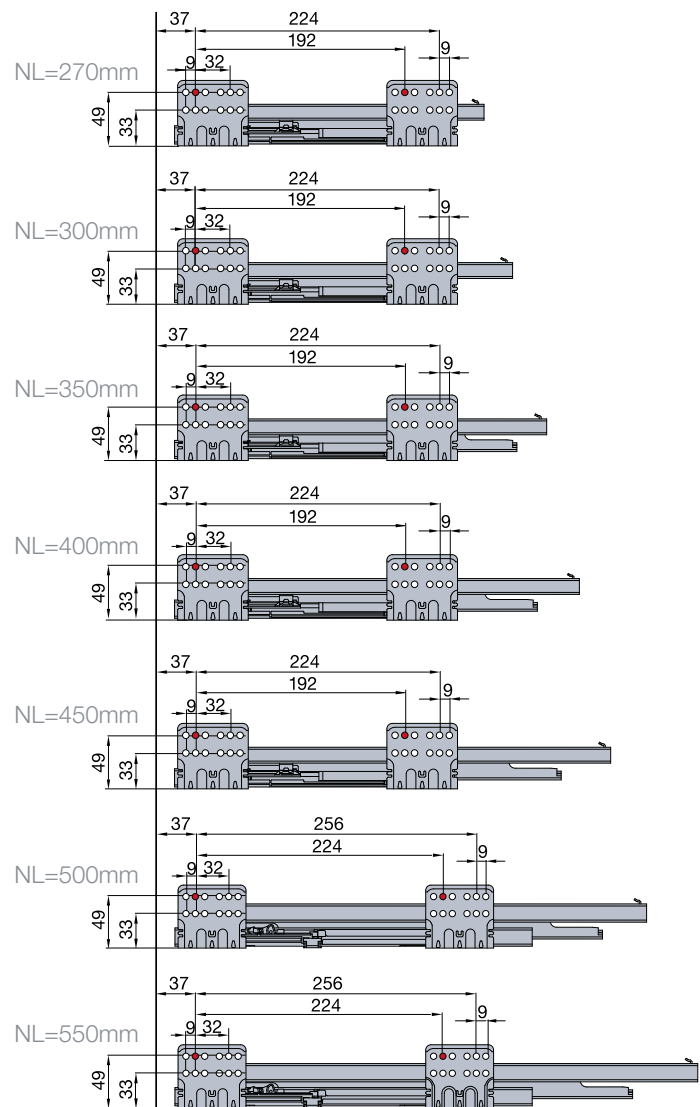

Inner Drawer Front for Tekform Slimline Drawer DW182 with High Glass

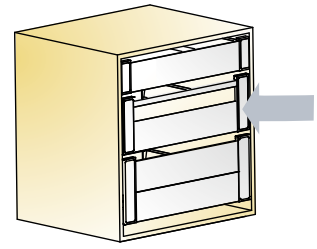

Front panel





Cutting dimension L = ICW-100
ICW → see page 3.38

 20 pcs

Made of aluminium

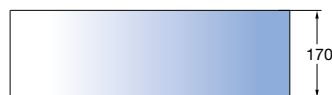
Front glass panel - high



 5 pcs
10 pcs (655-8280, 655-8165,
655-8281, 655-8166)



Made of glass

Front bracket

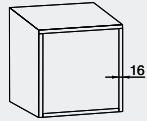
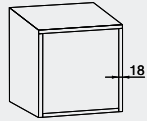

 20 sets

Made of aluminium and plastic

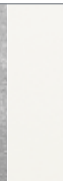
ECW	Cabinet side Thickness=16mm	Cabinet side Thickness=18mm			
External cabinet width					
Item number	Item number	White	Antracite grey	Transparent glass	
1200	655-8085 →	511	515		
600	655-8280 →	655-8165 →			392
800	655-8281 →	655-8166 →			392
900	655-8282 →	655-8167 →			392
	655-8172 →	350	385		

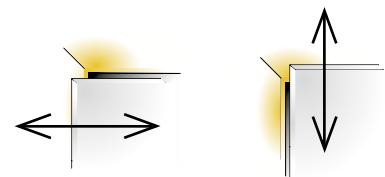
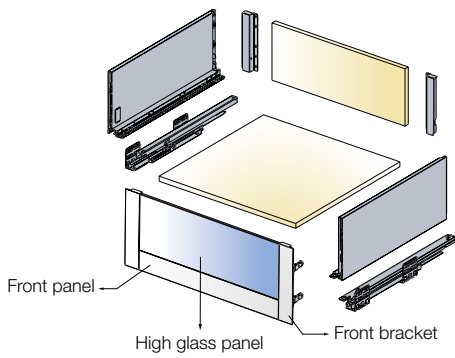

Side adjustment
+1/-1mm

Height adjustment
+2/-2mm

For further explanation → see page 3.10

Installation dimensions

Drawer runner fixing positions

Minimum space required for the cabinet

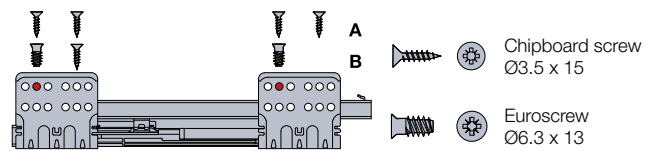
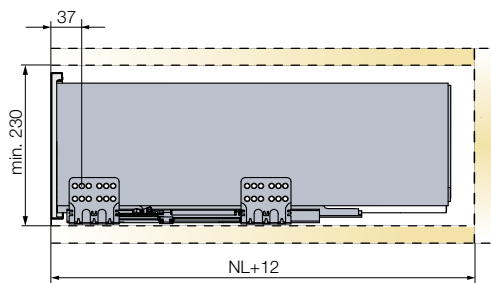

⚠ Use the second hole for runner fixing.

Cutting dimensions details

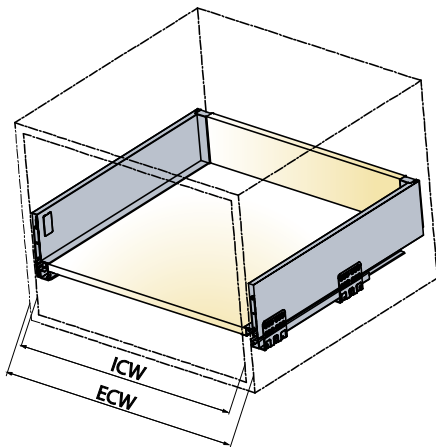

ECW: External cabinet width
ICW: Internal cabinet width
NL: Nominal length of drawer

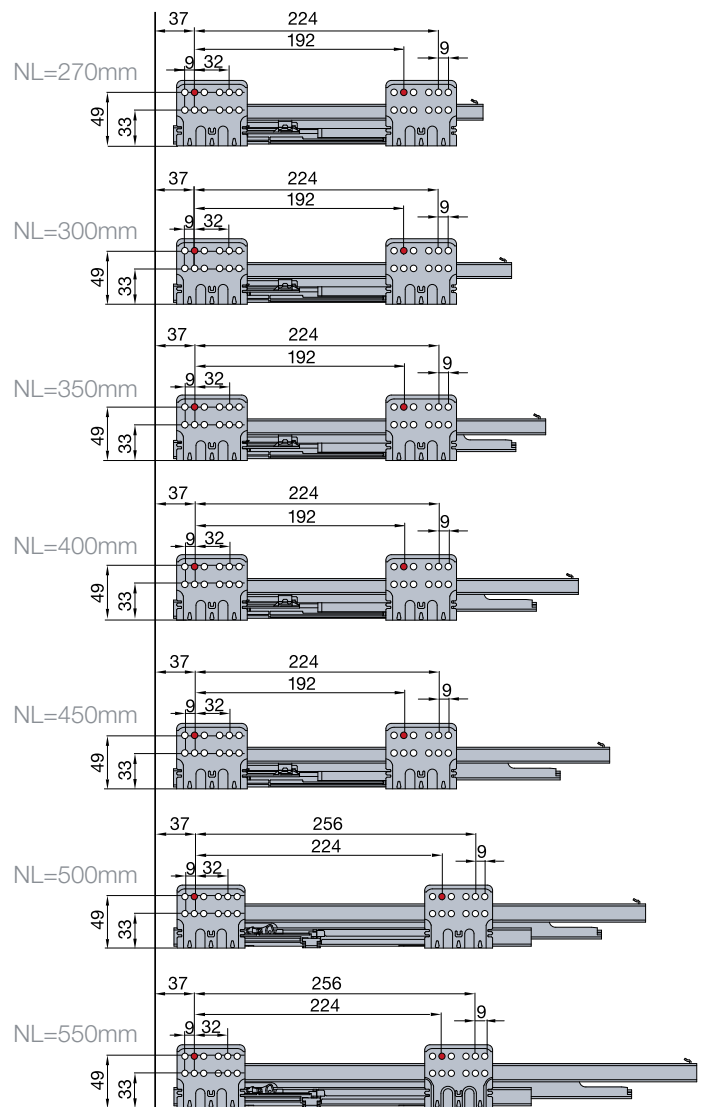

Accessories

Tacto Slimline Mechanism

Touch Opening

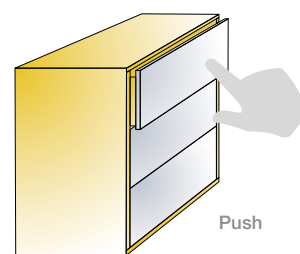

Technical details

Item number

Zinc plated

655-9152

040

Set of 2 mechanisms (one drawer application):
655-9152-040-K1

PushOpen
Mechanism



2 pcs

Chipboard
screws



4 pcs

Mounting
instructions



1 pc/set

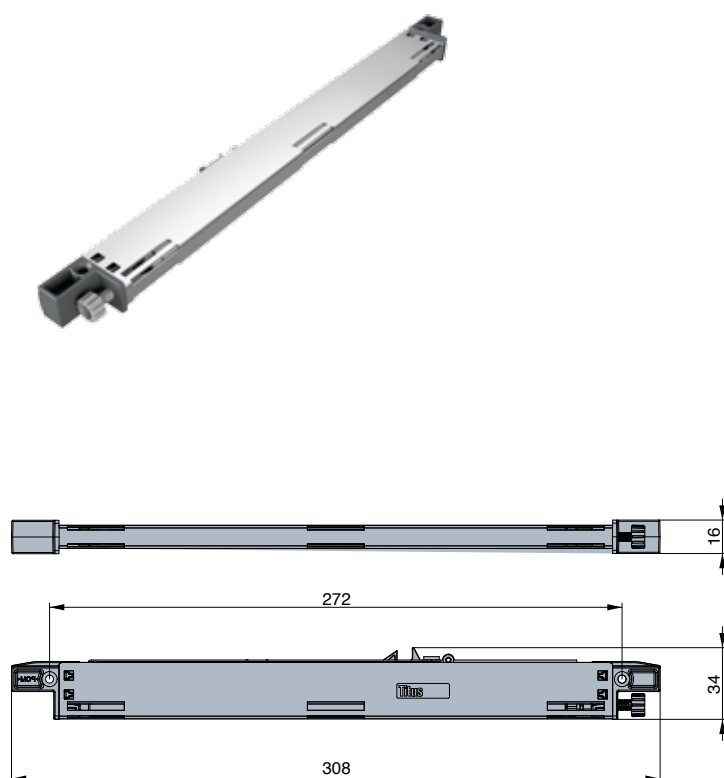

30 sets

Made of steel and plastic

- Fast and intuitive mounting without pre-drilling
- Reliable and secure closing
- Non handed design
- Narrow 1.5mm operating gap for evenly aligned fronts

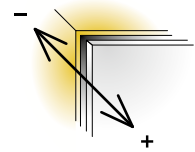

Depth adjustment
-0.5/+2.5mm



Works only with Tacto Slimline
→ see page 3.47

Mounting details

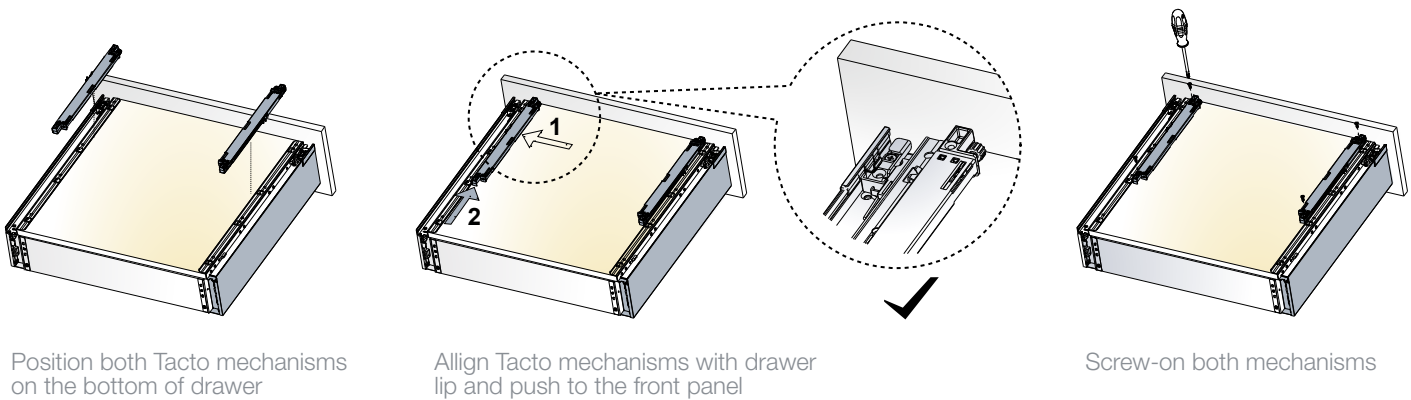

Position both Tacto mechanisms on the bottom of drawer

Align Tacto mechanisms with drawer lip and push to the front panel

Screw-on both mechanisms

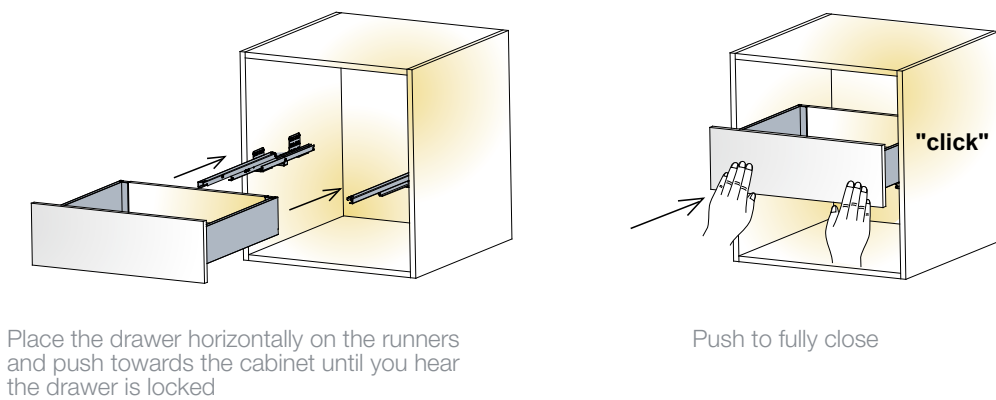

Place the drawer horizontally on the runners and push towards the cabinet until you hear the drawer is locked

Push to fully close



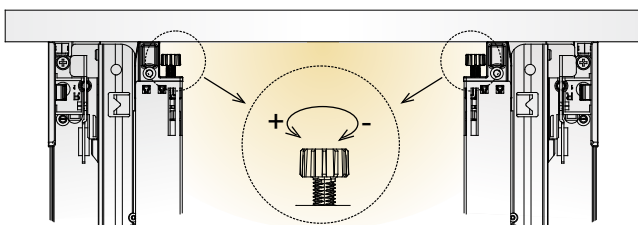

Depth adjustment



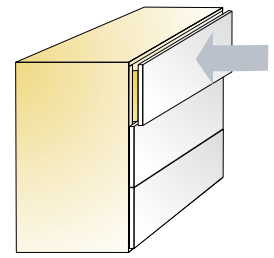

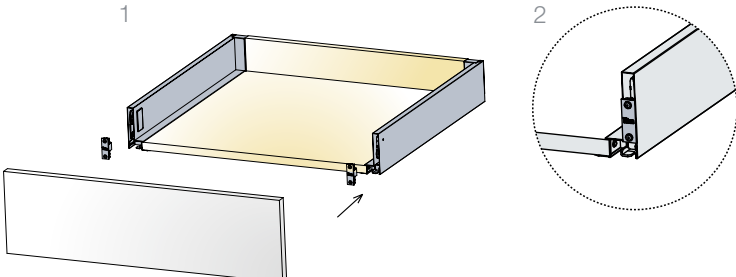

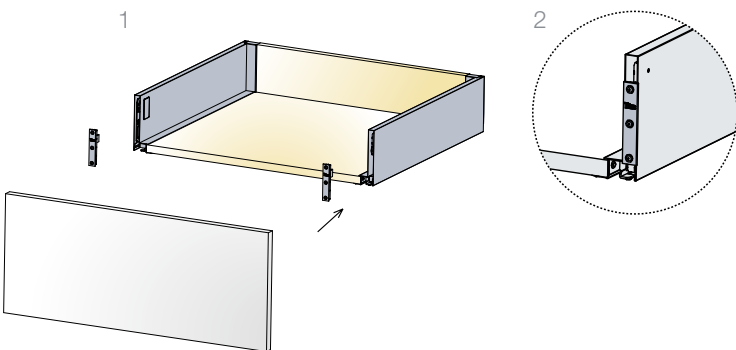

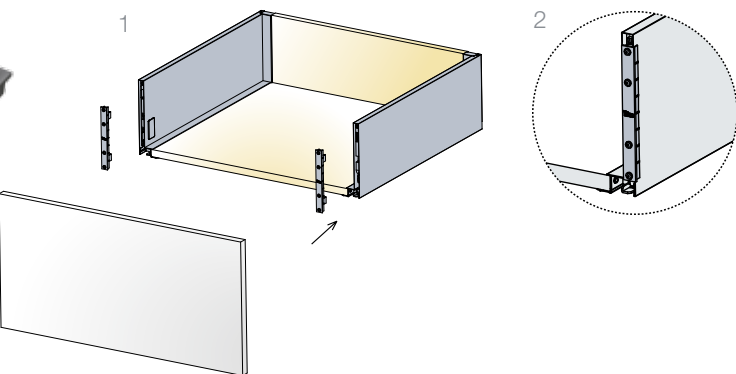

Accessories

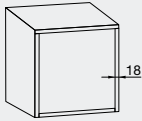
Marking Jig

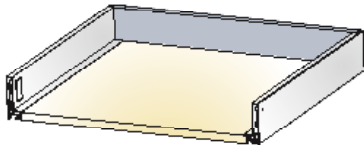

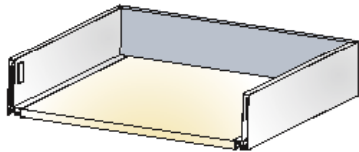
		Item number	Black
<p>Marking jig for Tekform Slimline drawer DW70</p>   <p>1 set Made of plastic and steel</p>		655-8016 →	390
<p>Marking jig for Tekform Slimline drawer DW100</p>   <p>1 set Made of plastic and steel</p>		655-8017 →	390
<p>Marking jig for Tekform Slimline drawer DW145 and DW182</p>   <p>1 set Made of plastic and steel</p>		655-8018 →	390

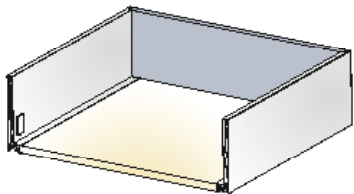
Steel Back Panel

		External cabinet width	Cabinet side Thickness=18mm 	
			Item number	Antracite grey
Steel back panel DW70		600	655-7L60 →	185
		800	655-7L80 →	185
				
Mounting → see page 3.47				
 10 pcs	Made of steel			
Steel back panel DW145		600	655-7M60 →	185
		800	655-7M80 →	185
				
Mounting → see page 3.47				
 10 pcs	Made of steel			
Steel back panel DW182		600	655-7H60 →	185
		800	655-7H80 →	185
				
Mounting → see page 3.47				
 10 pcs	Made of steel			

Assembly Instructions



Screws are not included

Assembly Sequence

Connect the drawer sides to the bottom panel (1) and fix it with screws (2)

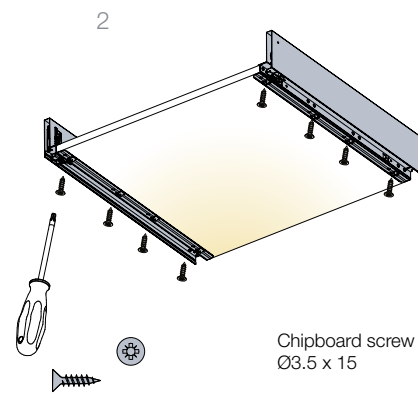
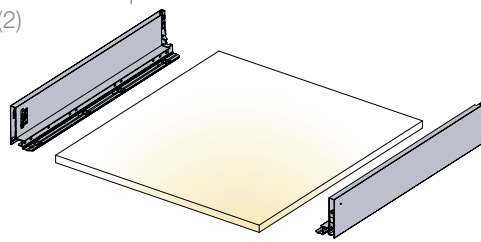

Insert the rear connector vertically (3) and push it downwards into recess in the drawer side (4)

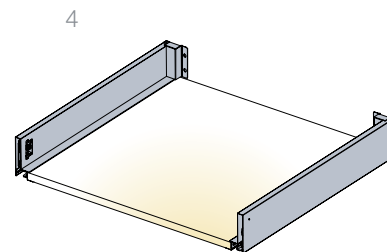
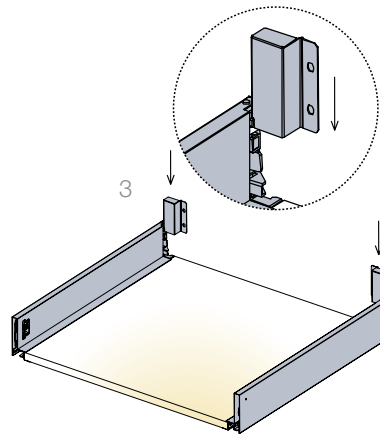

Insert the back panel (5) and fix it with screws (6)

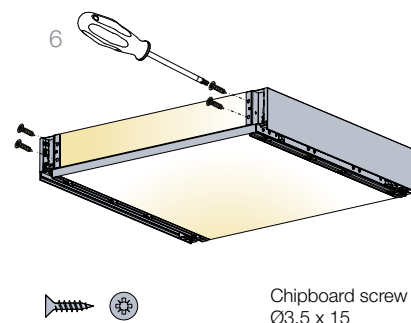
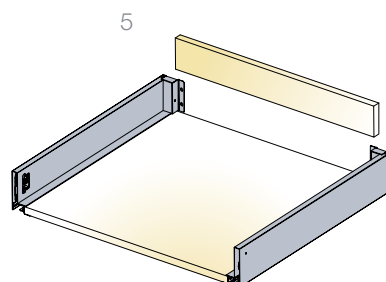



Screws are not included

Insertion of Front Connectors

EasyFix

Insert the front connectors into holes on the front panel

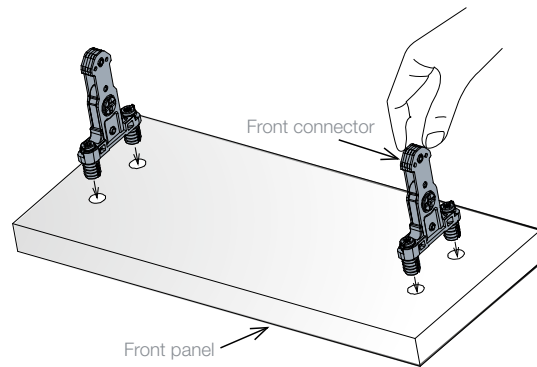

Turn the screws 90° into locked position

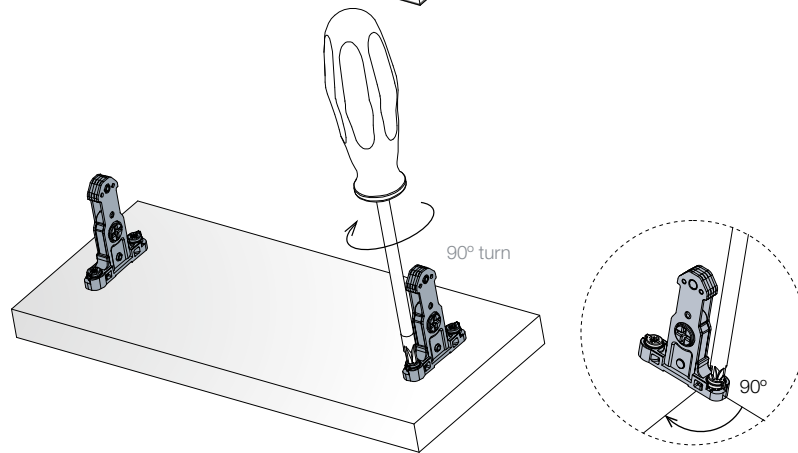

Screw-in fixing

Use Ø3 x 15mm screws for fixing

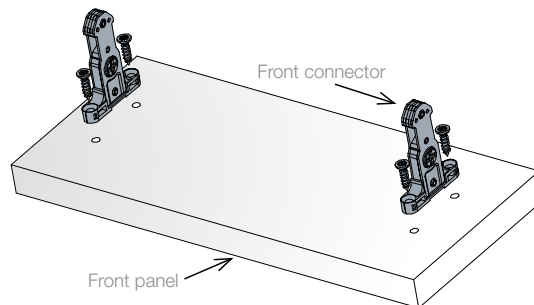

Chipboard screw
Ø3.5 x 15

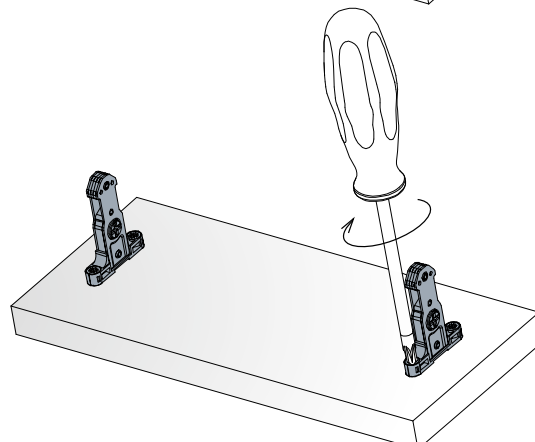

Assembly Instructions

Front Panel Mounting / Removal

Mounting

Attach the front panel to the drawer and press to click

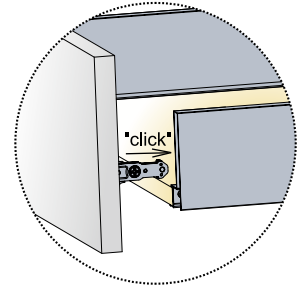
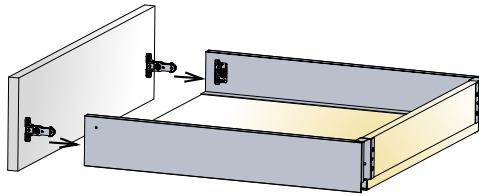

Removal

Turn the screw towards the front panel

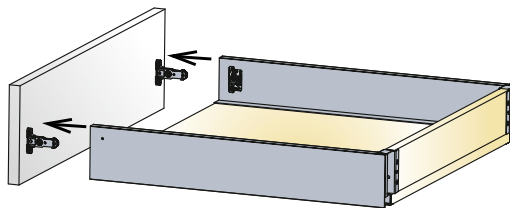
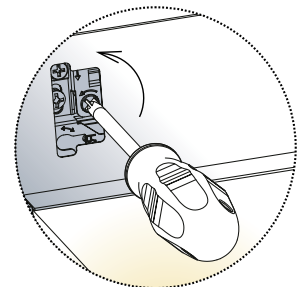
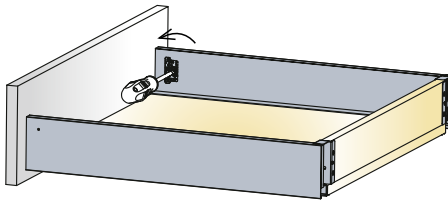

Drawer Insertion / Removal

Insertion

Place the drawer horizontally on the runners and push towards the cabinet until you hear the drawer is locked

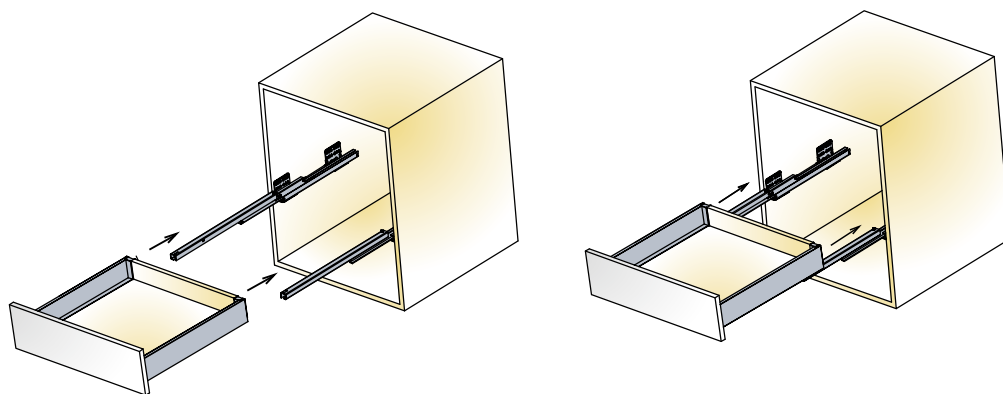

Push to fully close

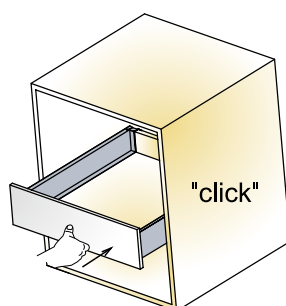

Removal

Press-up the button under the drawer. Keep pressed to pull the drawer out

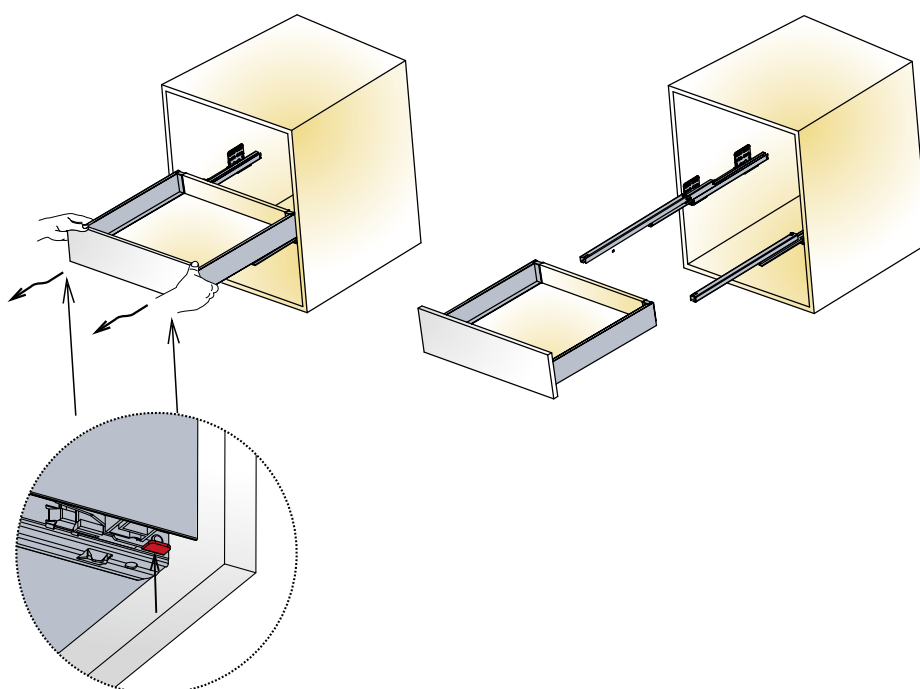

Press-up

Accessories Mounting

Steel Back Panel

 Screws are not included

Assembly Sequence

Insert the steel back panel vertically and push it downwards into recess in the drawer sides (1)

Slide the bottom panel horizontally into recess at the bottom of drawer sides (2)

Fix the bottom panels with screws (3)

Fix the steel back panel with screws (4)

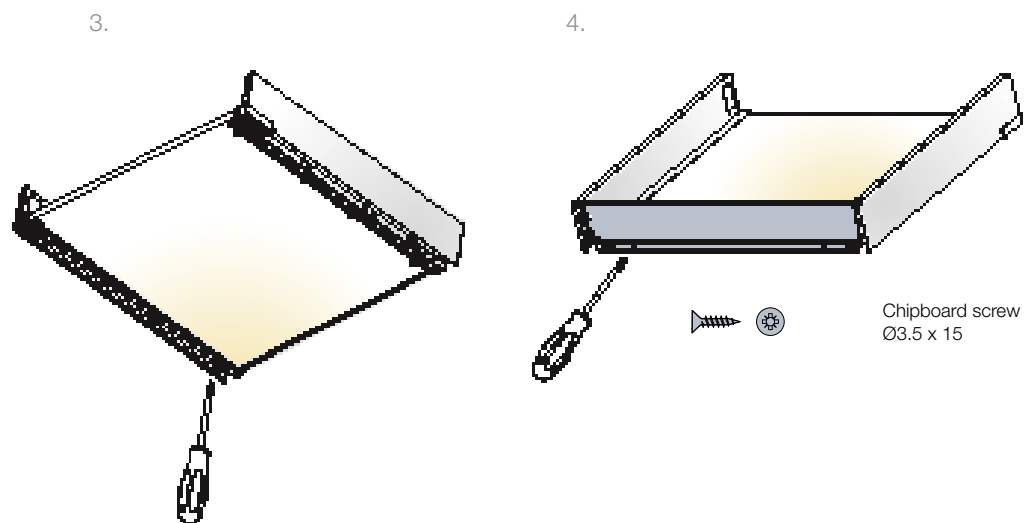
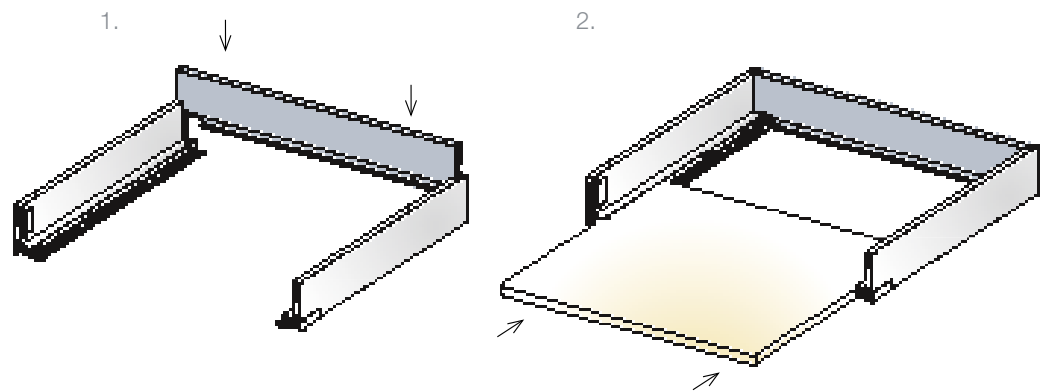

Assembly of Inner Drawer Front

Slimline DW70

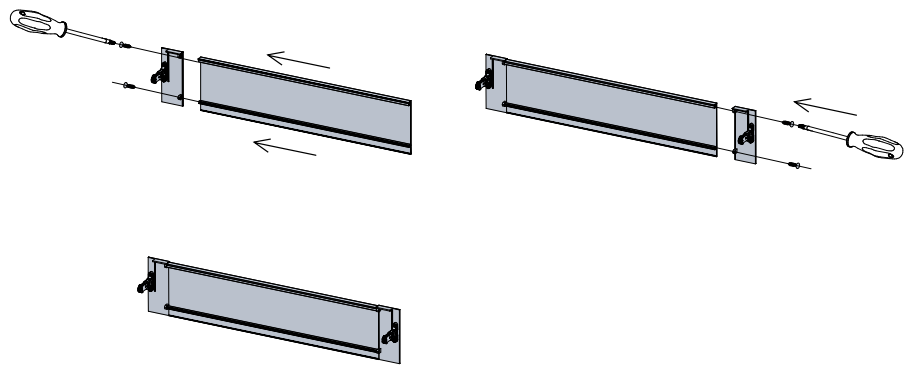

Slimline DW145 and DW182
with bar

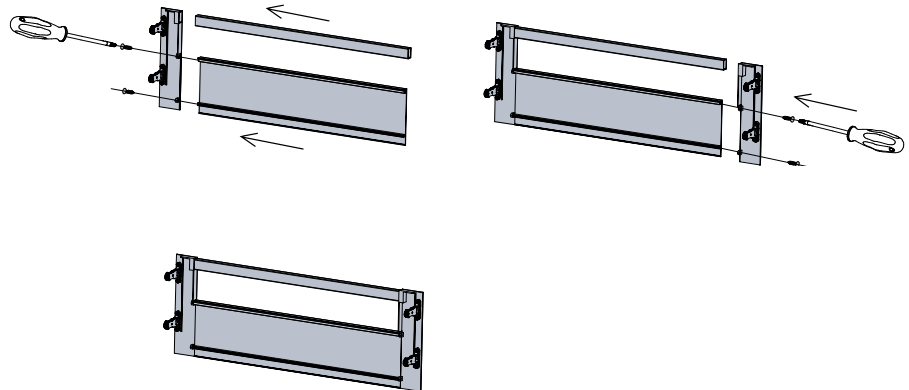

Slimline DW70, DW145 and
DW182 with glass

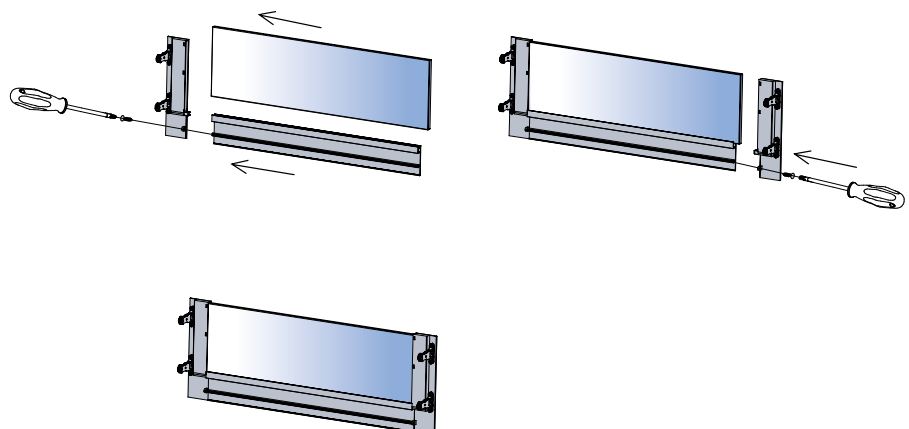

Soft Closing Systems for Sliding Doors and Drawers

Slidix Soft Closing Systems



Titus Damper Inside

- A fully programmable/controllable damping curve
- Precise definition of forces over the whole damping action
- Easy to fine tune performance to specific application

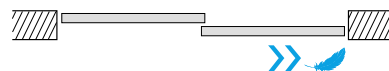

Fully controllable damping path

- Smooth and even soft closing on various dimensions and weights
- Reliable damping at any closing speed
- Silent closing without a rebound



Consistent performance

- Reliable closing of doors from 15 to 120 kg at any closing speed
- The door will close even at minimum speed

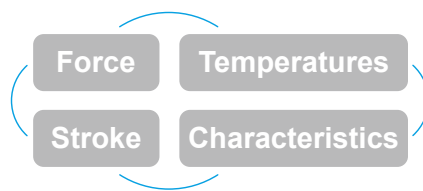
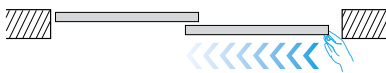

Comfortable door opening

- Low pull-open force
- Effortless opening

Wide range of customization options

- Easy to fine-tune to specific application
- Several options of damper forces, spring forces and damper characteristics

Compact size

- Low spacial and protrusion impact on the application
- Fits numerous application options
- Manufacturer needs less adaptation to fit mechanism to its door situation

Slidix System Information

Overview

Functional principles

Damping mechanism works in conjunction with activator; mounting of each on moving or fixed object of application depends on the application specifics.

Activator catches the trigger - pushes the piston rod to activate damping function.

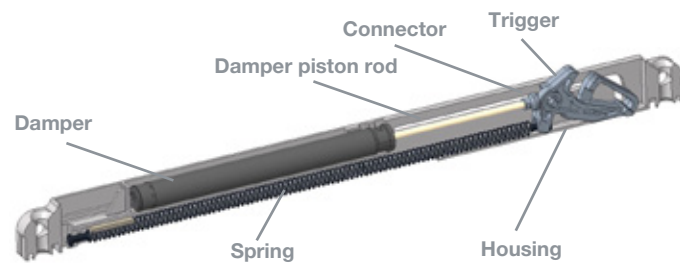

Technical details

Temperature range	-30 °C to 70 °C
Stroke length	50mm or 100mm
Load capacity	15kg to 120kg
Damper force	2.5N to 22.5N
Spring force	4.3N to 17N
Damping characteristics	flat, progressive, MultiStage, with final release

Direction of movement

Depending on the application the user can choose from various options of movement: from outside-in, inside-out or both directions.

A position of trigger on Slidix defines the direction of movement. Pictures below show trigger in released position.

Inside-out

Slidix TB
Slidix TC
Slidix TE



Trigger is positioned on the inside of Slidix mechanism for damping towards end of the mechanism.

Outside-in

Slidix II
Slidix TA
Slidix TF



Trigger is positioned on the outside of Slidix mechanism for damping towards inside of the mechanism.

In both directions

Slidix Centro



Slidix Centro has double trigger centered in the middle to enable damping from left/right towards centre.

Overview

Areas of application

Architectural doors: interior wall partitions, and sliding doors, pocket doors, barn doors

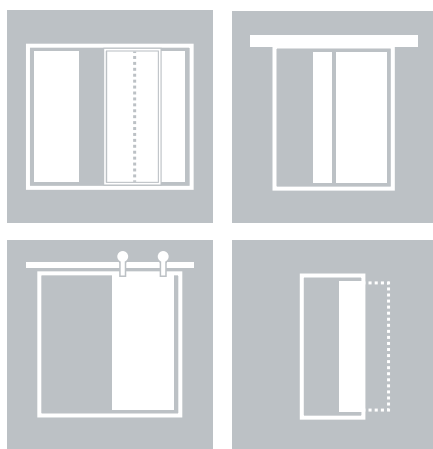

Wardrobes and walk-in closets

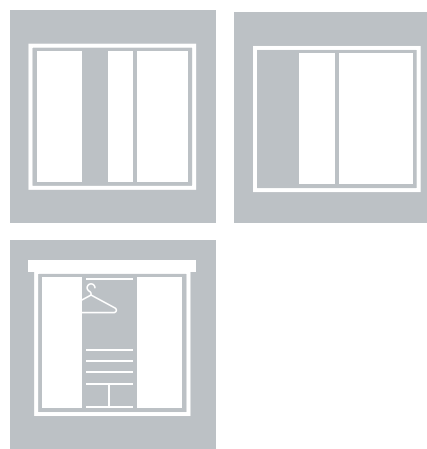

Drawers and pull-out systems

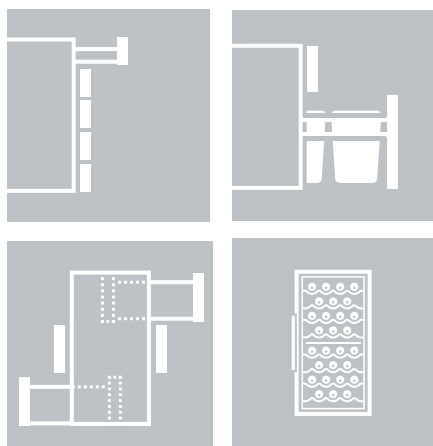

Shower doors

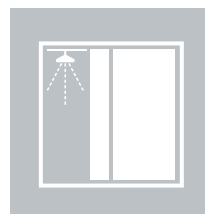

Operating scope

Slidix	Direction of movement	Damping stroke	Load capacity
Slidix Centro	Outside-in (in both directions)	50mm in 2 directions	15kg to 40kg
Slidix II	Outside-in	50mm	15kg to 80kg
Slidix TA	Outside-in	100mm	40kg to 120kg
Slidix TB	Inside-out	100mm	40kg to 80kg
Slidix TC	Inside-out	50mm	15kg to 60kg
Slidix TE	Inside-out	50mm	15kg to 60kg
Slidix TF	Outside-in (in both directions)	100mm in 2 directions	40kg to 120kg

Slidix Centro

For middle sliding door damping and centering

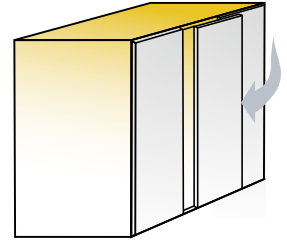

- Movement type
- Stroke length in mm
- Damper type

In both directions
50 left + 50 right
Hydraulic

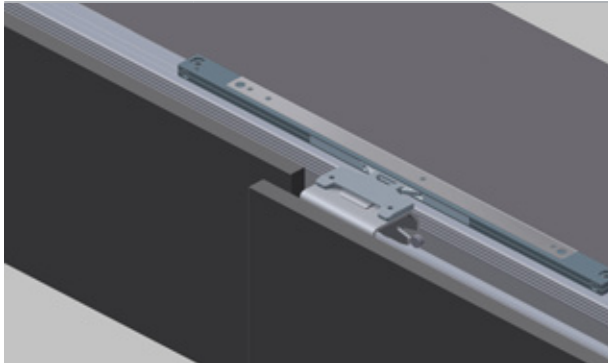

Slidix Centro



Technical details

Door weight (kg)

Spring force (N)

Item number

15

12

975-9216-040

25

12

975-9217-040

40

15

975-9218-040

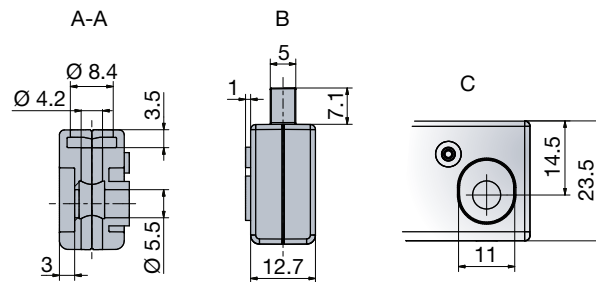
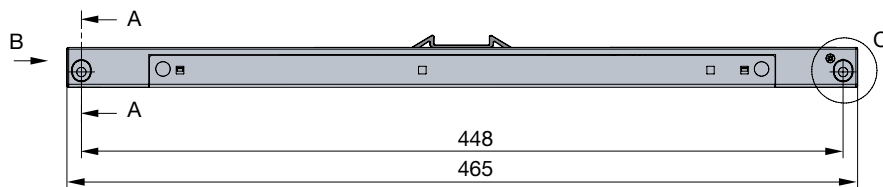

20 Pcs

Made of plastic, steel cover

Activators



Activator TSC Plus
→ see page 4.21

- Consistent and reliable soft closing of middle cabinet door
- Optimal middle door centering assures confident door alignment
- Damping of middle door in both directions with one additional Slidix mechanism
- Titus hydraulic dampers ensure smooth and even soft closing action in both directions

Load capacity

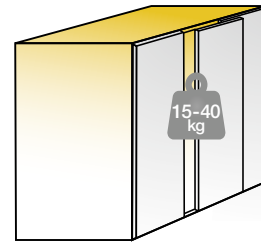

Works in range from 15-40 kg per door



Works only with activator TSC Plus
→ see page 4.21

Application details

Drawing shows the needed mounting distance between Slidix mechanism and activator TSC Plus.

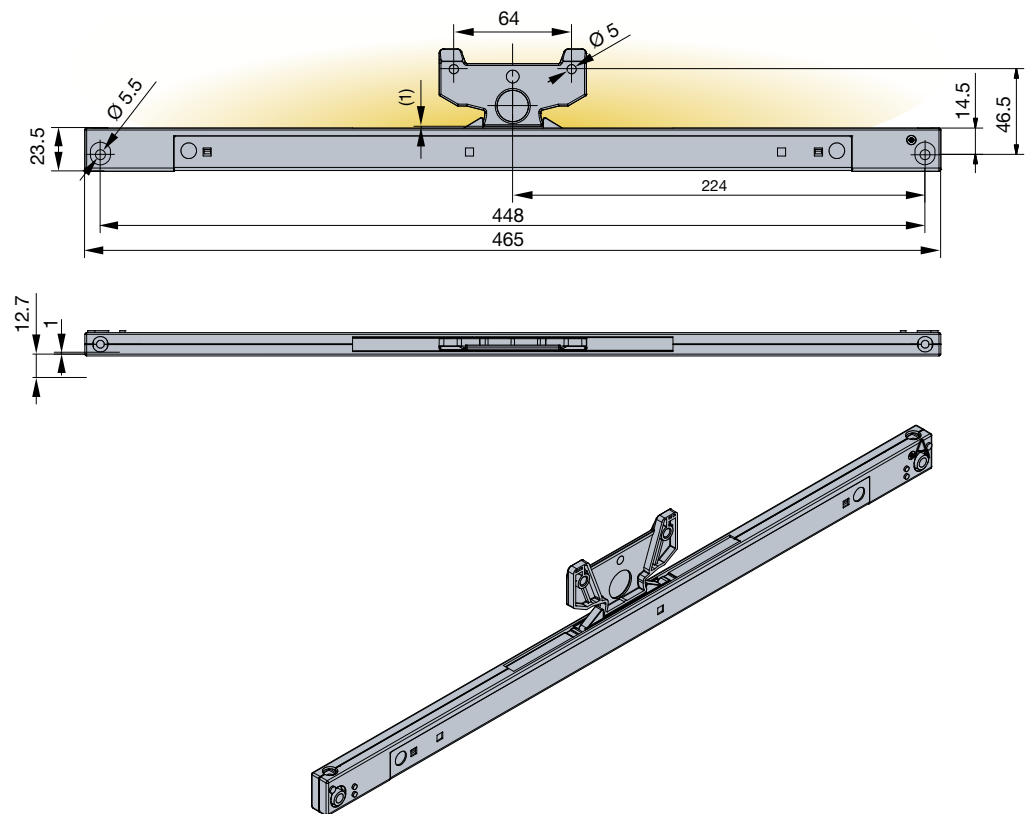

Applications

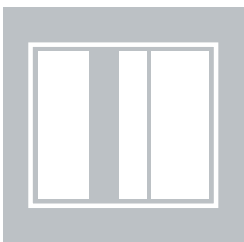

3-door sliding door cabinet

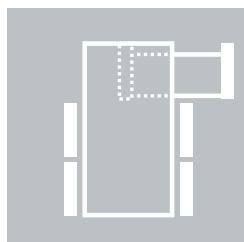

two way runners

Slidix II

For drawers and sliding doors

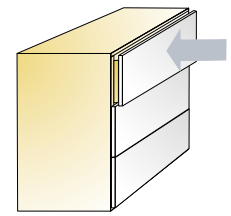
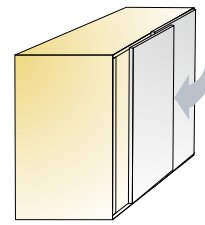

- Movement type
- Stroke length in mm
- Damper type

Outside-in
50
Hydraulic

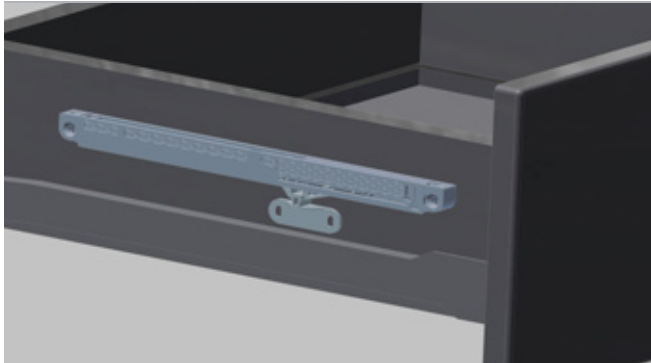

Slidix II

Technical details

Door weight (kg)

Spring force (N)

Item number

15	4.3	975-9456-380
25	7.5	975-9457-380
40	10	975-9459-380
60	13	975-9461-380
80	13	975-9462-380

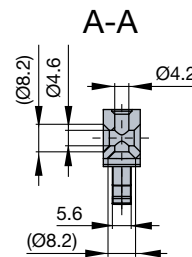
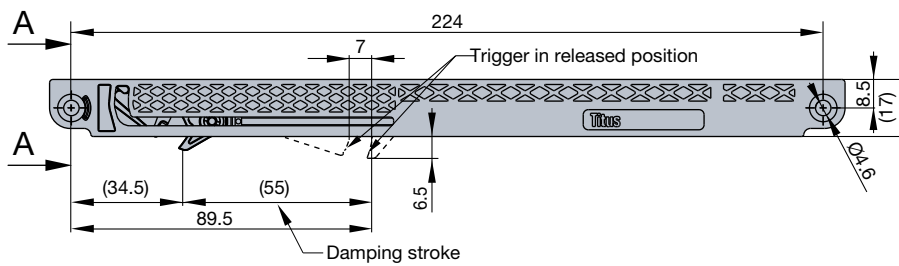

100 Pcs

Made of plastic

Activators



Slidix activators
→ see pages 4.21 and 4.22

- Smooth and reliable closing
- Compatible with most of the drawer slides and sliding door applications
- Titus hydraulic dampers ensure smooth and even soft closing action

Load capacity

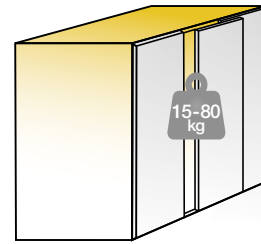

Works in range from 15-80 kg per door

Application details

Drawing shows the needed distance in mounting between Slidix mechanism and activator SP14. Other activators available, trial mounting is recommended.

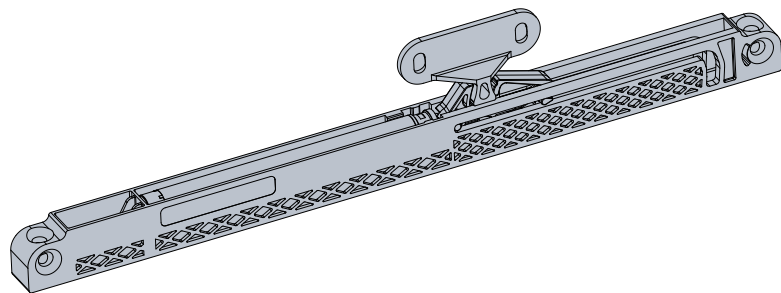
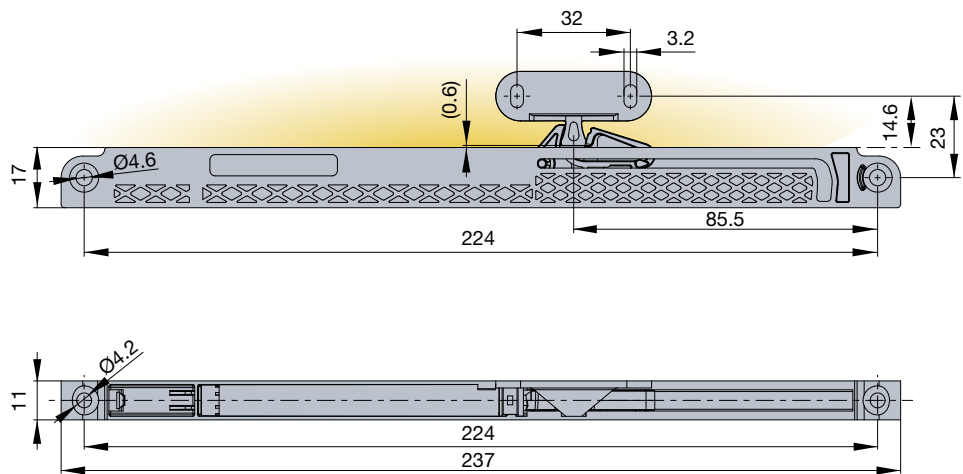

Applications



Interior sliding doors

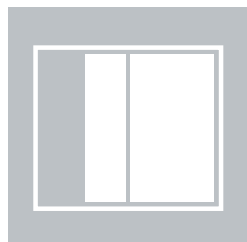

wardrobes

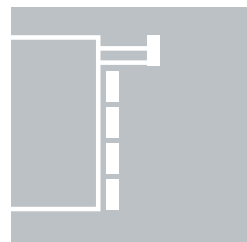

drawers

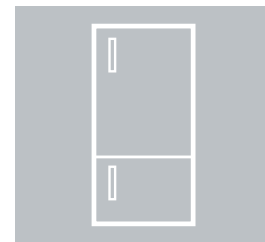

refrigerators

Slidix TA

For heavy sliding doors

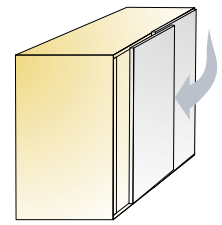

- Movement type: Outside-in
- Stroke length in mm: 100
- Damper type: Hydraulic

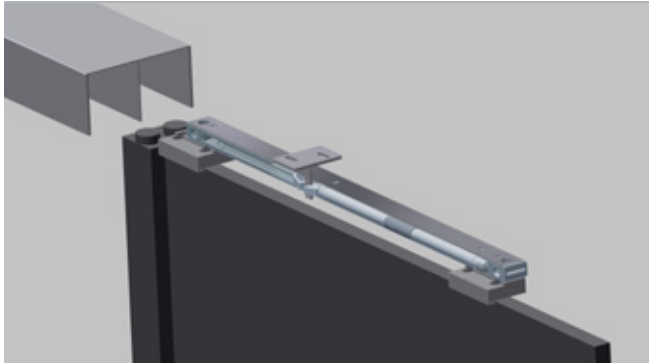

Slidix TA

Technical details

Door weight (kg)	Spring force (N)	Item number
40	10	975-9436-040
60	13	975-9437-040
80	13	975-9440-040
100	17	975-9442-040
120	17	975-9443-040

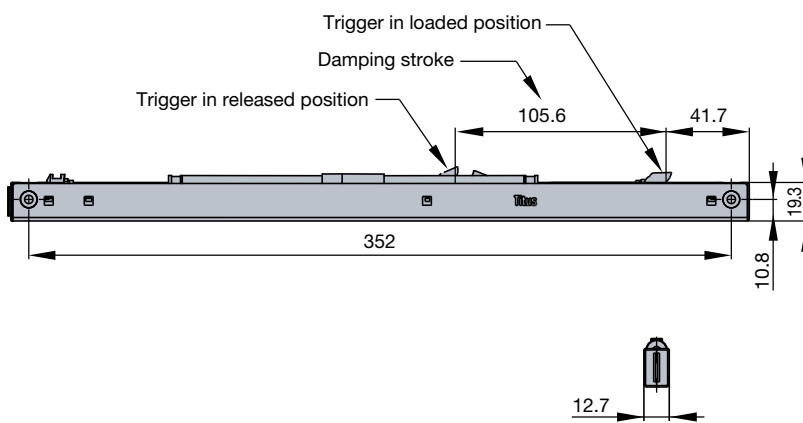

100 Pcs

Made of plastic, steel cover

Activators



Slidix activators
 → see pages 4.21 and 4.22

- Consistent and reliable soft closing of sliding doors with heavier weight
- Reinforced with a metal housing for secure performance on any door material, including glass
- Titus hydraulic dampers ensure smooth and even soft closing action

Capacity

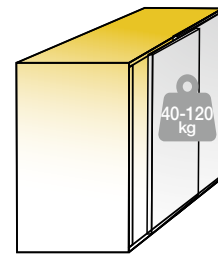

Works in range from 40-120 kg

Application details

Drawing shows the needed distance in mounting between Slidix mechanism and activator SP14. Other activators available, trial mounting is recommended.

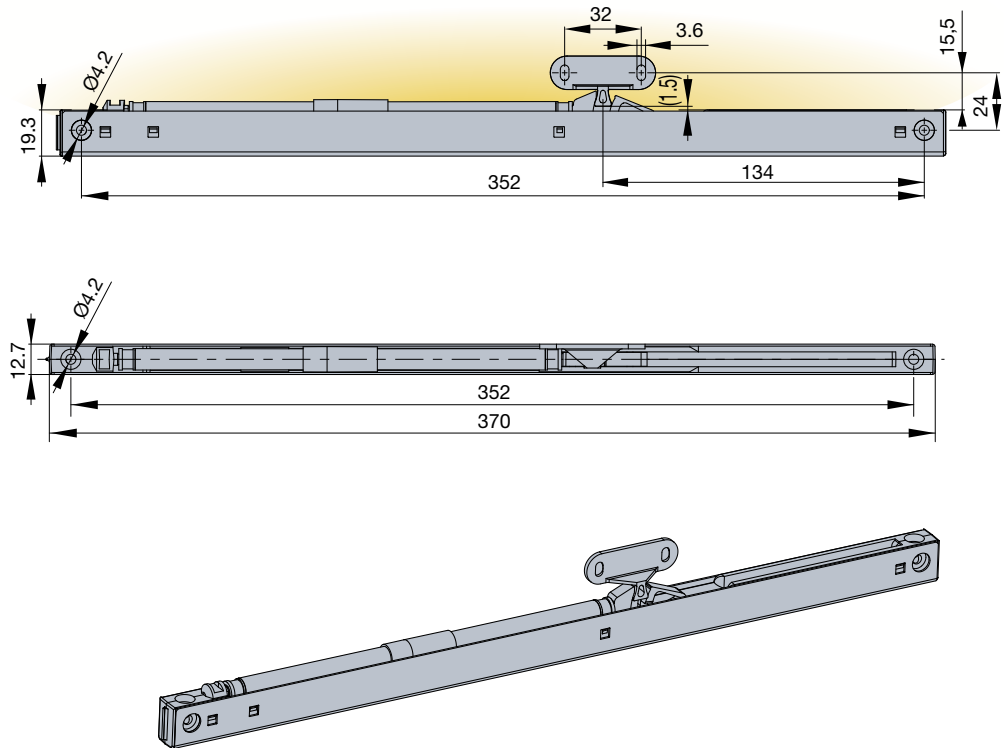

Applications



interior sliding doors

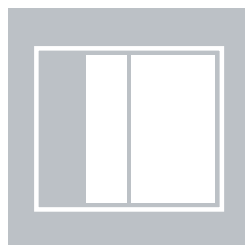

wardrobes



room dividers

Slidix TB

For wardrobes with sliding doors

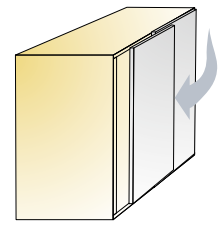

- Movement type: Inside-out
- Stroke length in mm: 100
- Damper type: Hydraulic

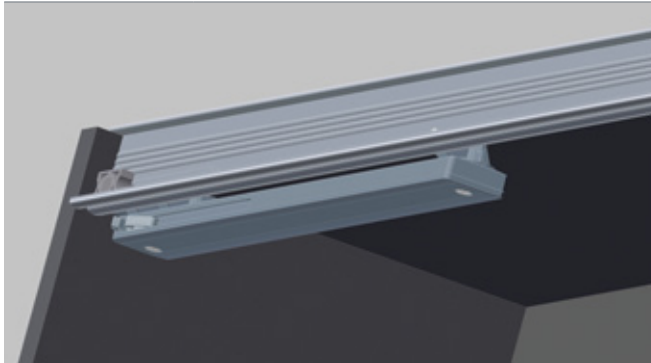

Slidix TB

Technical details

Door weight (kg)

Spring force (N)

Item number

40	15	975-9492-380
60	15	975-9271-380
80	15	975-9272-380

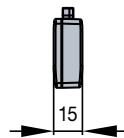
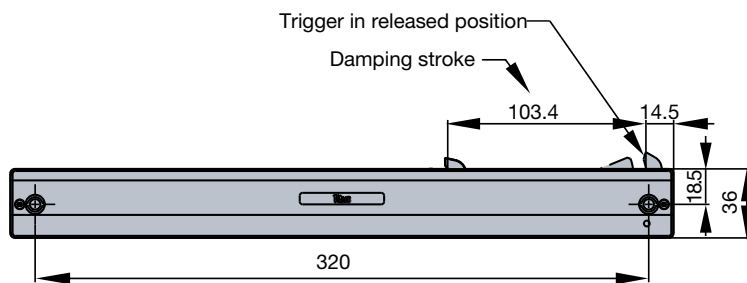

100 Pcs

Made of plastic

Activators



Slidix activators
→ see pages 4.21 and 4.22

- Consistent and reliable damping of heavier doors
- For soft closing of wardrobes with 2 doors, can be added to top running sliding door systems
- Titus hydraulic dampers ensure smooth and even soft closing action

Capacity

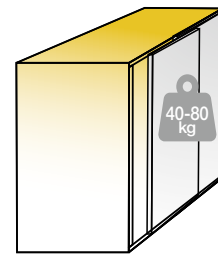

Works in range from 40-80 kg

Application details

Drawing shows the needed distance in mounting between Slidix mechanism and activator SP14. Other activators available, trial mounting is recommended.

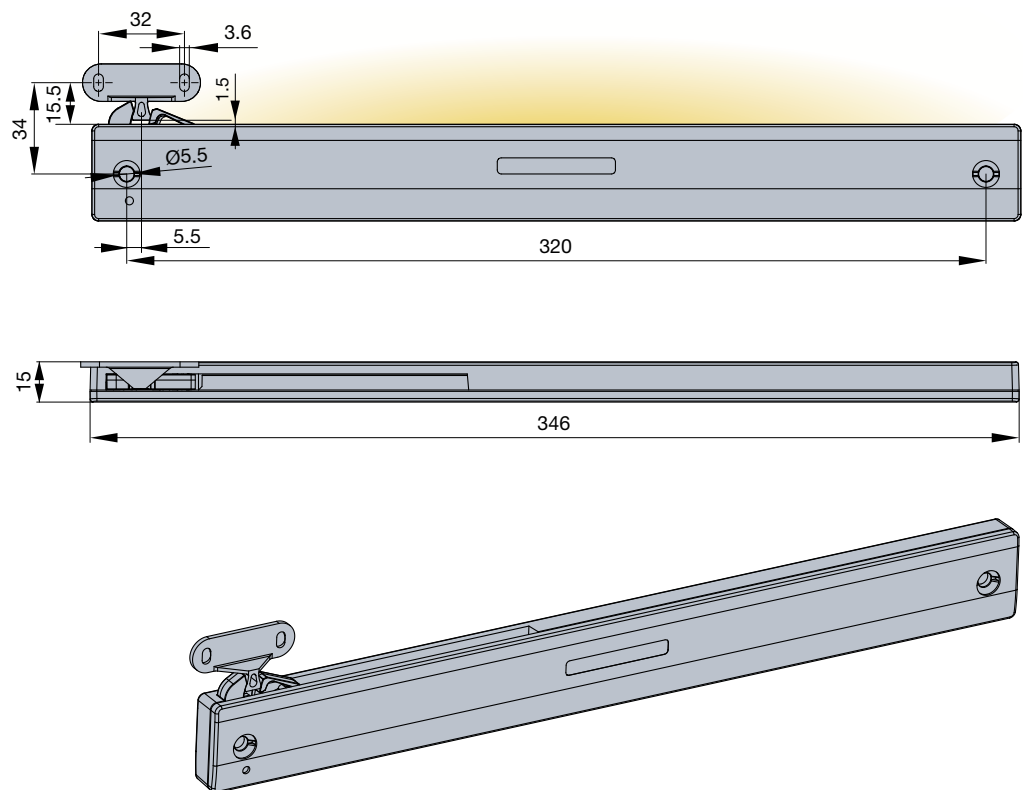

Applications

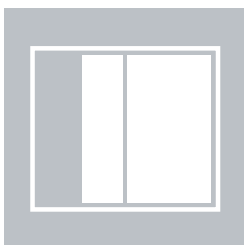

wardrobes

Slidix TC

For wardrobes with sliding doors

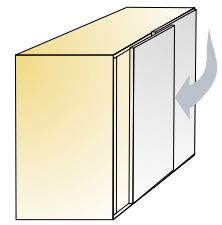

- Movement type Inside-out
- Stroke length in mm 50
- Damper type Hydraulic

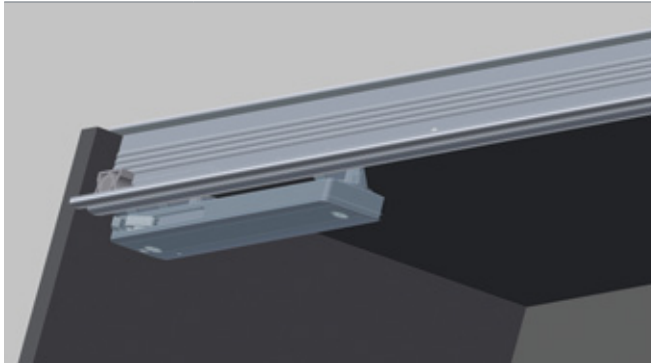

Slidix TC



Technical details

Door weight (kg)

Spring force (N)

Item number

15	4.3	975-9333-380
25	7.5	975-9341-380
40	10	975-9342-380
60	13	975-9347-380

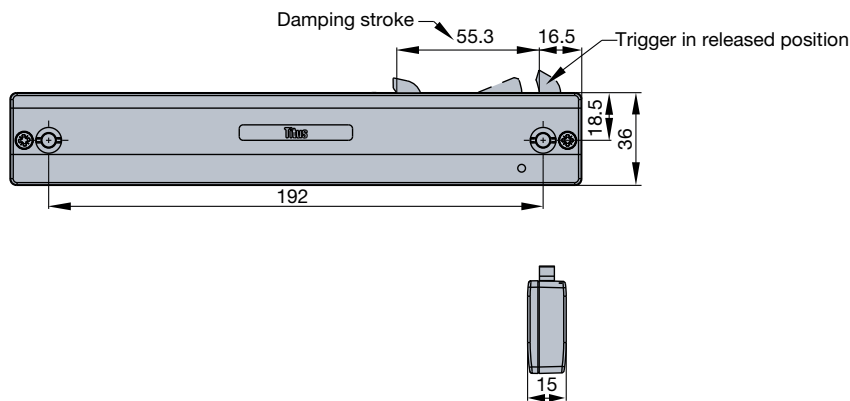

100 Pcs

Made of plastic

Activators



Slidix activators
→ see pages 4.21 and 4.22

- Consistent and reliable soft closing of sliding doors with lighter weight
- For soft closing of smaller and lower wardrobes with lighter doors, can be added to top running sliding door systems
- Titus hydraulic dampers ensure smooth and even soft closing action

Capacity

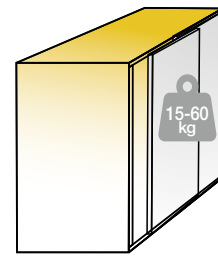

Works in range from 15-60 kg

Application details

Drawing shows the needed distance in mounting between Slidix mechanism and activator SP14. Other activators available, trial mounting is recommended.

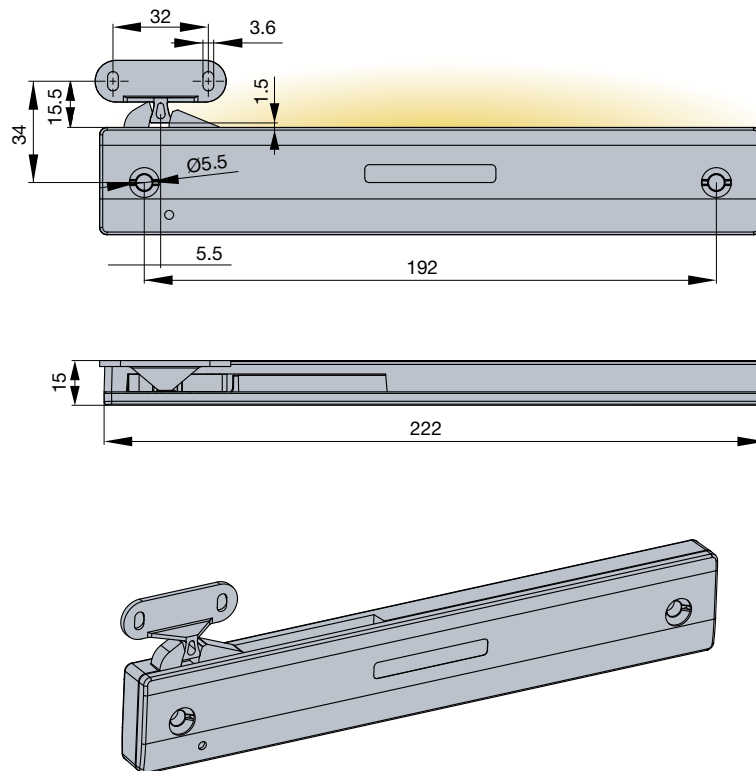

Applications



interior sliding doors

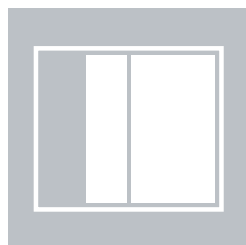

wardrobes

Slidix TE

For sliding and shower doors

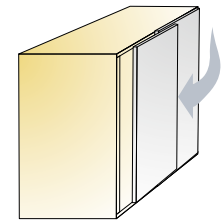

- Movement type Inside-out
- Stroke length in mm 50
- Damper type Hydraulic

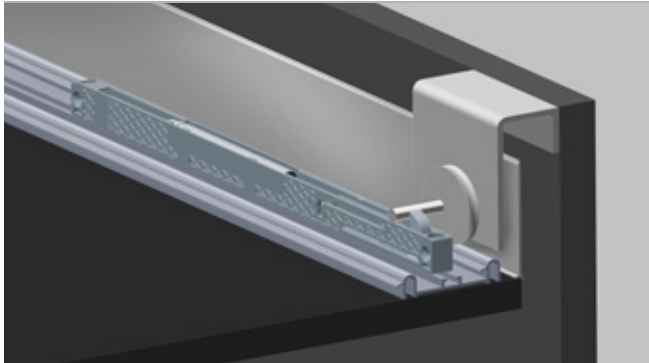

Slidix TE

Technical details

Door weight (kg)

Spring force (N)

Item number

15	4.3	975-9315-380
25	7.5	975-9317-380
40	10	975-9321-380
60	13	975-9483-380

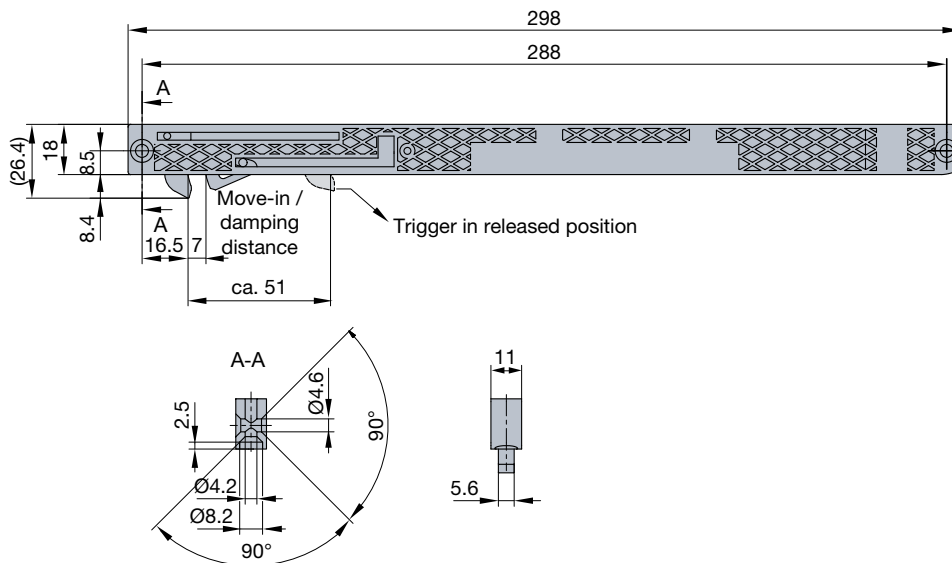

100 Pcs

Made of plastic

Activators



Slidix activators
→ see pages 4.21 and 4.22

- Smooth and reliable soft closing of various sliding doors, including shower cabins and other glass sliding doors
- Titus hydraulic dampers ensure smooth and even soft closing action

Capacity

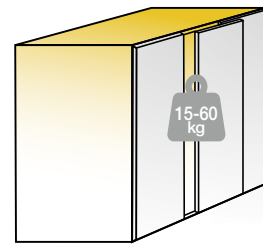

Works in range from 15-60 kg

Application details

Drawing shows the needed distance in mounting between Slidix mechanism and activator SP14. Other activators available, trial mounting is recommended.

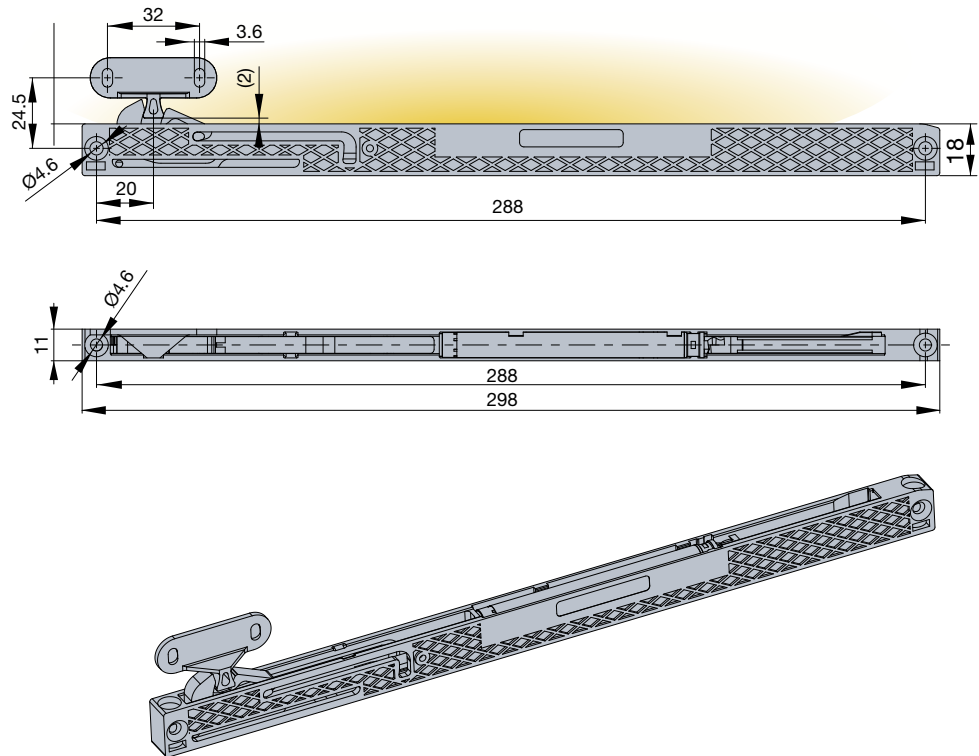

Applications options

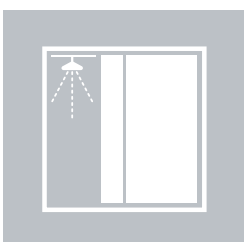

shower doors

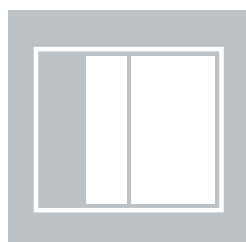

wardrobes sliding doors



interior sliding doors



walk-in closets

Slidix TF

For interior sliding door systems

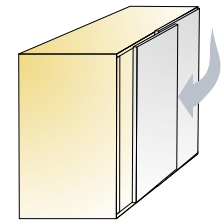

- Movement type: Outside-in
- Stroke length in mm: 100
- Damper type: Hydraulic

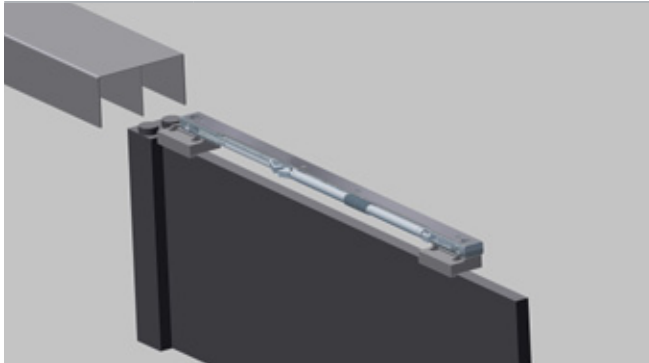

Slidix TF

Technical details

Door weight (kg)	Spring force (N)	Item number
40	10	975-9373-040
60	13	975-9374-040
80	13	975-9375-040
100	17	975-9376-380
120	17	975-9377-380

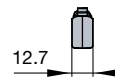
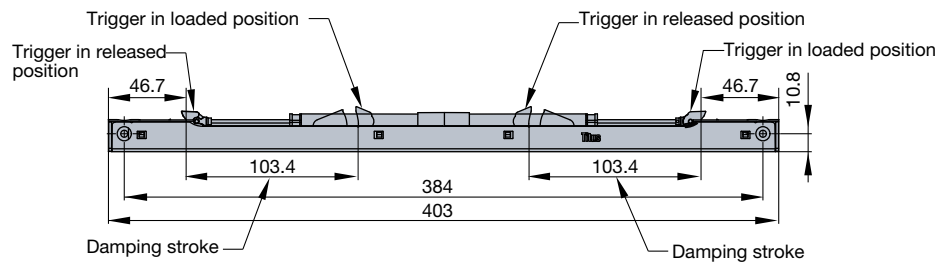

100 Pcs

Made of plastic, steel cover

Activators



Slidix activators
→ see pages 4.21 and 4.22

- Smooth and reliable soft closing of various sliding doors
- Titus hydraulic dampers ensure smooth and even soft closing action

Capacity

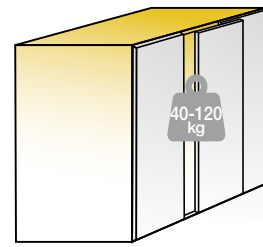

Works in range from 40kg to 120 kg

Application details

Drawing shows the needed distance in mounting between Slidix mechanism and activator SP14. Other activators available, trial mounting is recommended.

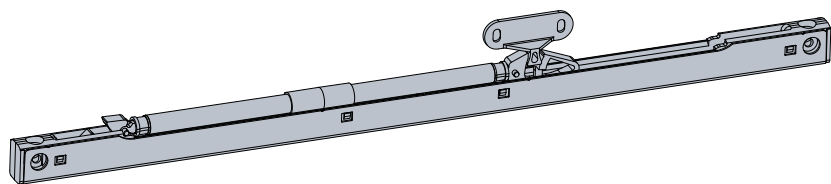
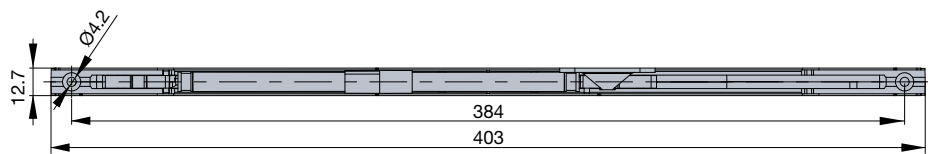
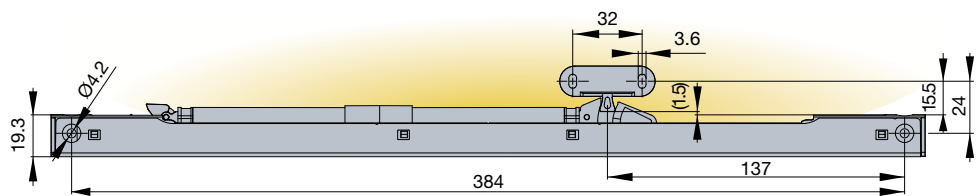

Applications options

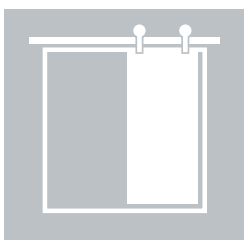



barn doors

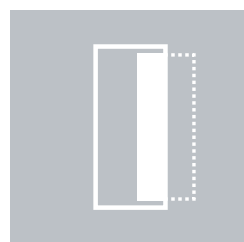

room dividers



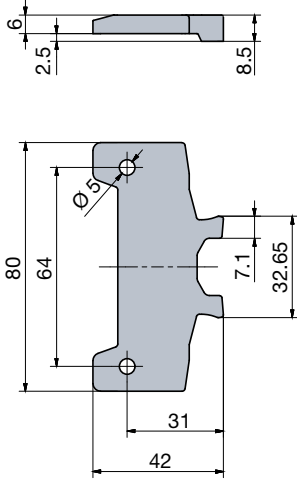

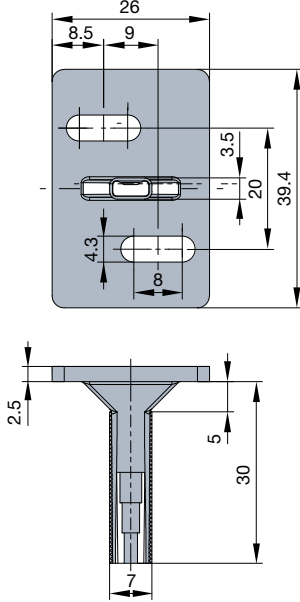







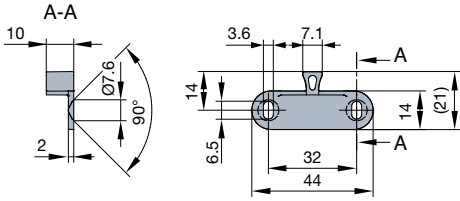

pocket doors

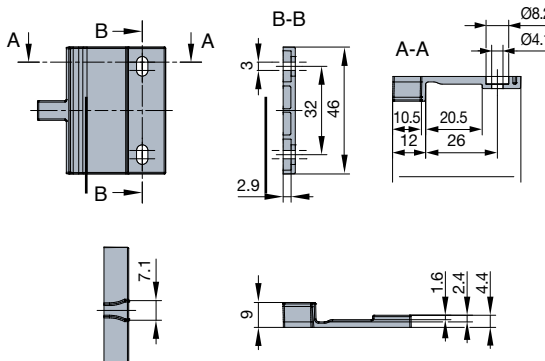
	Technical details	Item number	Grey
<p>Activator TSC Plus</p>  <p>100 Pcs Made of plastic</p>	<p>For Slidix Centro, II, TA, TB, TC, TE, TF</p> 	<p>974-4752 →</p>	<p>380</p>
<p>Activator TX40</p>  <p>100 Pcs Made of zamak</p>	<p>For Slidix II, TA, TB, TC, TE, TF</p> 	<p>974-4757 →</p>	<p>380</p>

Slidix Activators

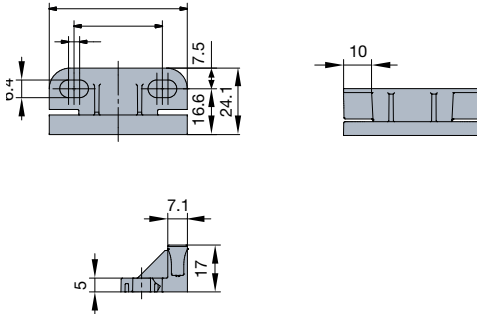
For Slidix mechanisms

					
Technical details		Item number	White	Grey	Black
Activator SP14 	For Slidix II, TA, TB, TC, TE, TF 	974-4748 		380	390
 100 Pcs	Made of plastic				
Activator SMZ 	For Slidix II, TA, TB, TC, TE, TF 	974-4747 	350	380	
 100 Pcs	Made of plastic				
Activator TS17 	For Slidix II, TA, TB, TC, TE, TF 	974-4753 			390
 100 Pcs	Made of plastic				

Titusoft Soft Closing Systems

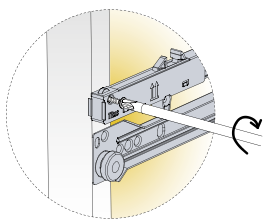

Simple and intuitive mounting

- No pre-drilling required
- Non-handed
- User friendly

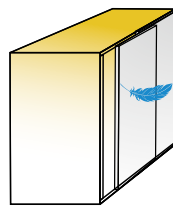

Smooth and reliable

- Silent in use
- Effortless opening with low pull-out force



Titus damper inside

- Efficient damping on various door sizes and weights
- ConfidentClose assured

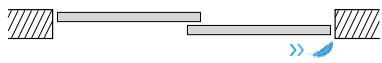

Fully controllable damping path

- Smooth and even soft closing on various dimensions and weights
- Reliable damping at any closing speed
- Silent closing without a rebound

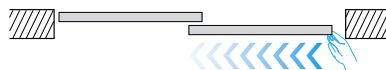

Comfortable door opening

- Low pull-open force
- Effortless opening

Titusoft WD

Soft Closing System for Wooden Drawer

For wooden drawer
with roller runners

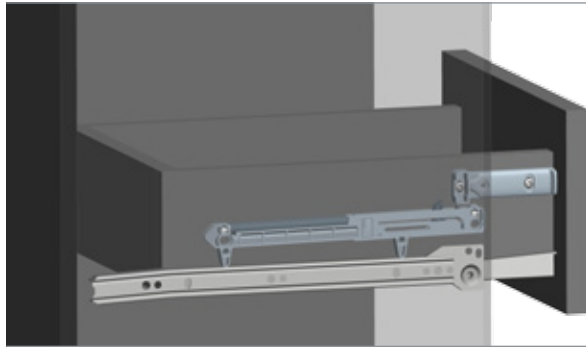
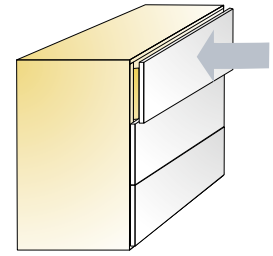

Technical details

Titusoft WD

Titusoft
mechanism

Item number

Grey

White

Zinc plated
blue

973-0X35 →

380

Activator

973-4451 →

380

350



Titusoft mechanism

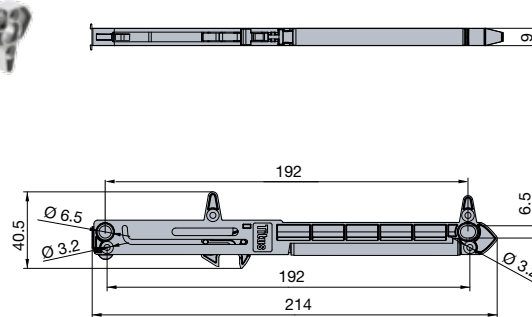

Bag of 1

973-0X35-380-K2  120 Bags

- 1 Titusoft mechanism
- 1 activator
- 2 screws Ø3.5mm x 20mm
- 2 screws Ø3.5mm x 12mm
- 1 mounting instruction sheet

Bag of 2

973-0X35-380-K1  80 Bags

- 2 Titusoft mechanisms
- 2 activators
- 4 screws Ø3.5mm x 20mm
- 4 screws Ø3.5mm x 12mm
- 1 mounting instruction sheet



Activator

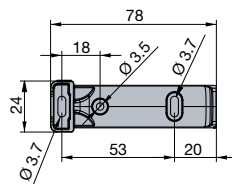

250 Pcs

200 Pcs (973-0X35 + activator)

Made of plastic

- Works with most roller runner drawer slides
- Easy, intuitive mounting
- Smooth, soft closing action independent of drawer hardware
- Optimal closing speed
- Non-handed design

Capacity chart

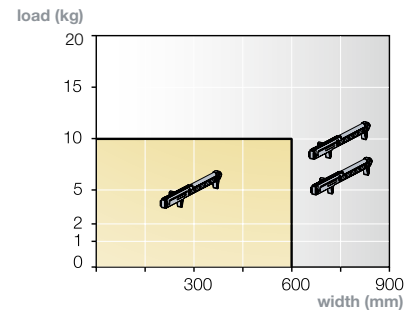

Mount 1 or 2 Titusoft mechanisms depending on drawer weight and width

Mounting details

1.

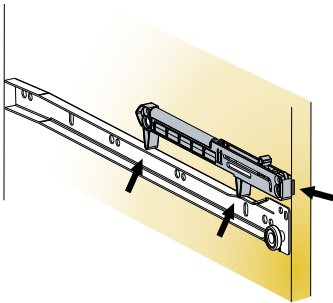

Position the Titusoft mechanism on the top of the drawer slide

2.

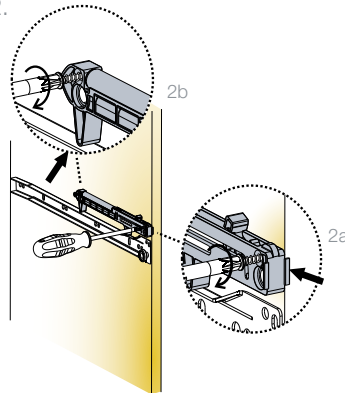

Fix with 2 screws L=20mm

3.

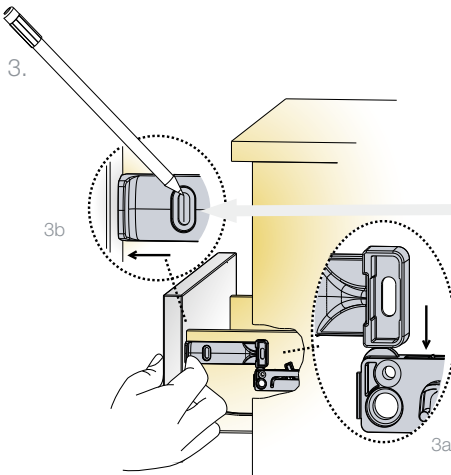

1. Rest the activator against the drawer front
2. Align the vertical position of the activator with the top of the Titusoft mechanism and mark the screw locations

4.

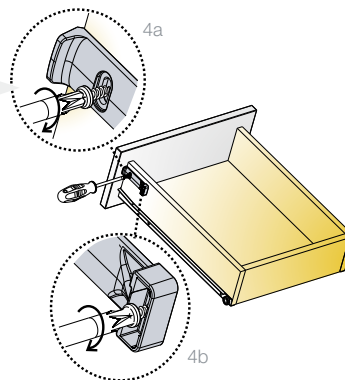

Fix with 2 screws L=12mm

A trial mounting is always recommended. Please contact Titus Group or your local distributor for further technical assistance.

Titusoft MD

Soft Closing System for Metal Box

For metal boxes

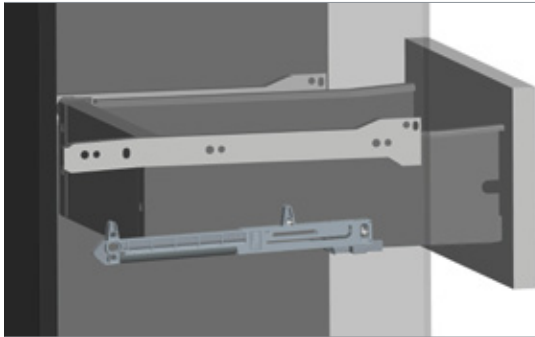
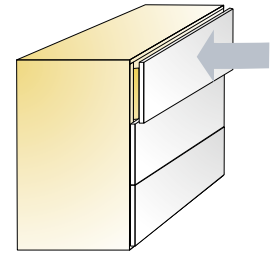

Titusoft MD



Item number	Grey	White	Light blue
Titusoft mechanism for factory mounting	380		
Titusoft mechanism for retrofit mounting	380		309
Activator		350	
Mounting jig			

Bag of 1
973-0X39-380-K2 90 Bags
 · 1 Titusoft mechanism
 · 1 activator
 · 1 mounting jig
 · 4 screws
 · 1 mounting instruction sheet

Bag of 2
973-0X39-380-K1 60 Bags
 · 2 Titusoft mechanisms
 · 2 activators
 · 1 mounting jig
 · 8 screws
 · 1 mounting instruction sheet

250 Pcs
 150 Pcs (973-0X39 + activator) Made of plastic

Technical details

Retrofit mounting

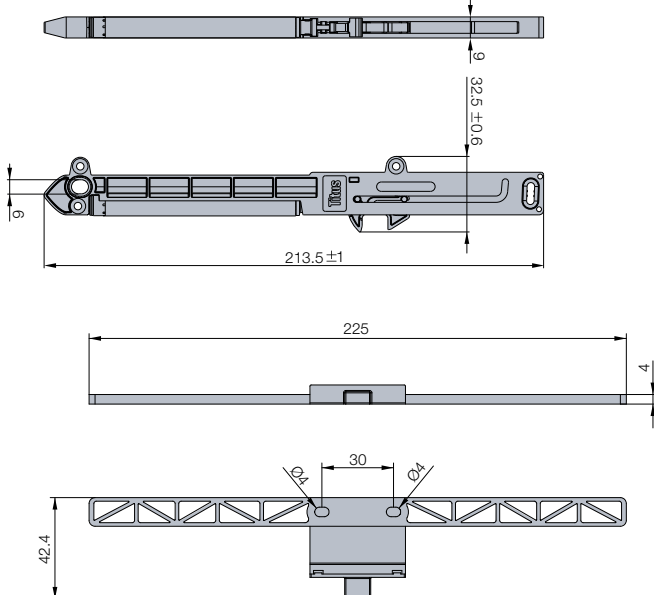

Factory mounting (system holes)

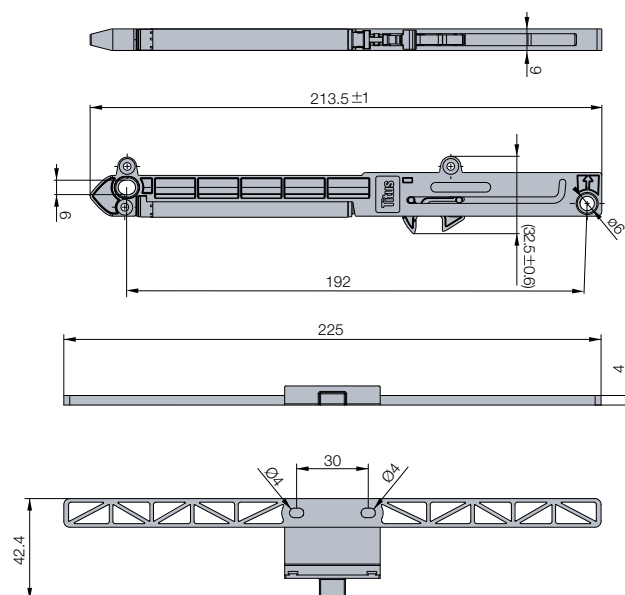

- One-for-all soft closing for single skin metal boxes
- Allows for easy factory mounting or retrofit application
- Intuitive positioning
- Preserve the life-time of the drawer

Capacity chart

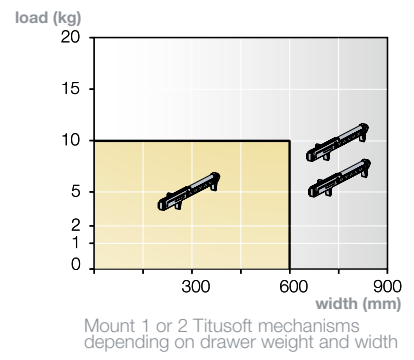

Mounting details

Retrofit mounting

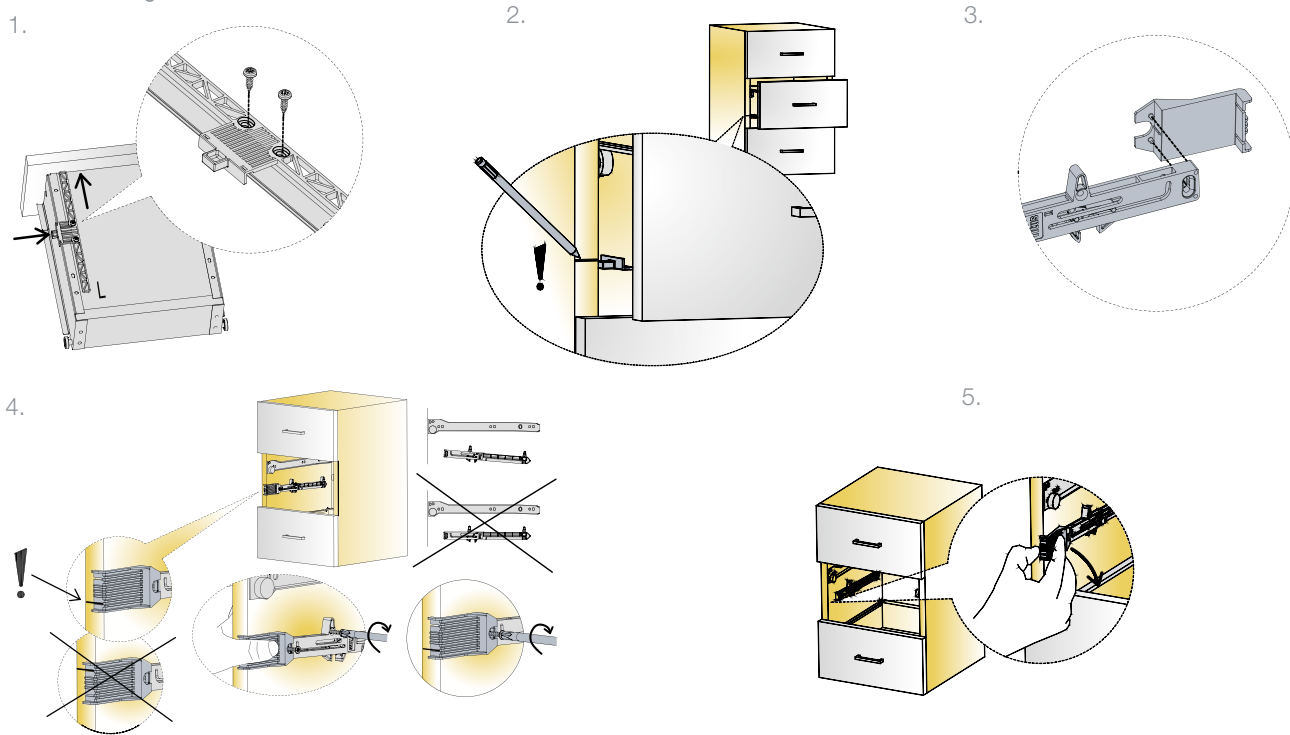

Factory mounting

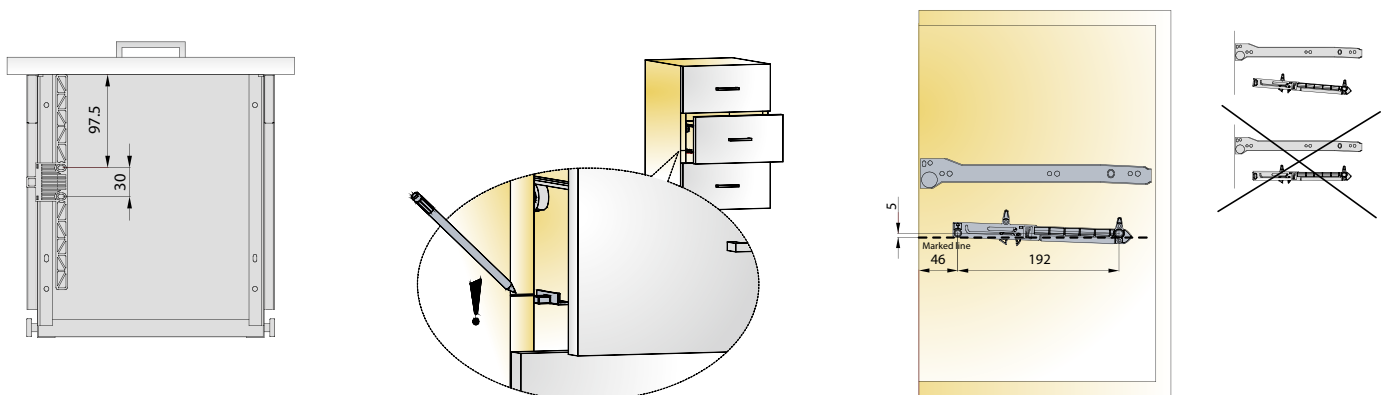

A trial mounting is always recommended. Please contact Titus Group or your local distributor for further technical assistance.

Titusoft FF

Soft Closing System
for Face Frame Cabinets
with Wooden Drawer

For wooden drawer
with roller runners

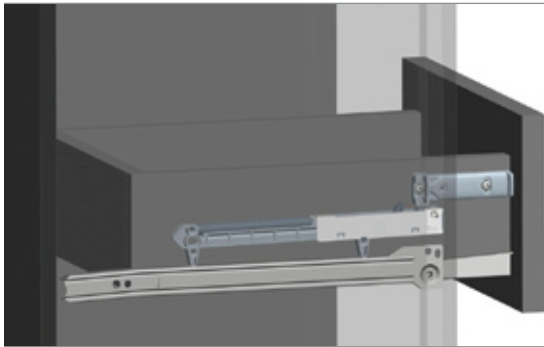
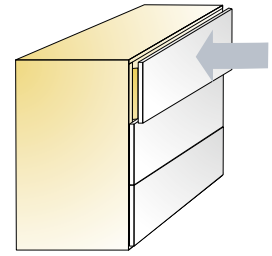

Technical details

Titusoft FF



Titusoft mechanism

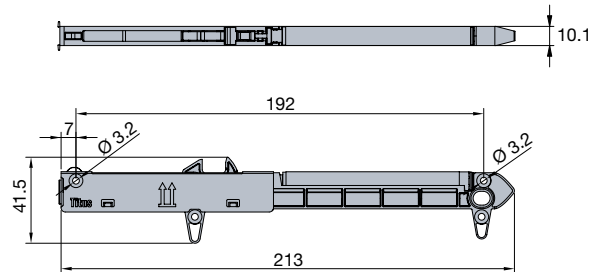

Activator

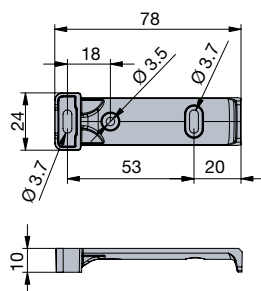

Item number	Grey	White
Titusoft mechanism 973-0M99 →	380	
Activator 973-4451 →	380	350

Bag of 1

973-0M99-380-K1  300 Bags

- 1 Titusoft mechanism
- 1 activator grey
- 2 screws Ø3.5mm x 25mm
- 2 screws Ø3.5mm x 12mm
- 1 mounting instruction sheet

 250 Pcs

Made of plastic

- Easy, intuitive mounting
- Universal application will fit most standard drawers
- Smooth, soft closing action independent of drawer hardware
- Non-handed design

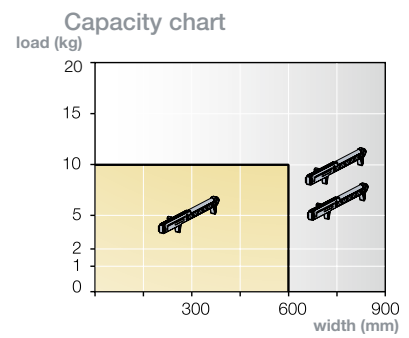

Mount 1 or 2 Titusoft mechanisms depending on drawer weight and width

Mounting details

1.

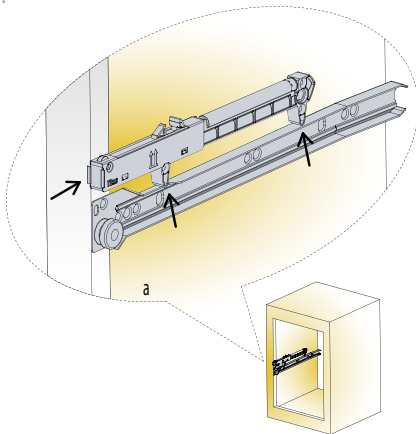

Position the Titusoft on the top of a drawer slide

2.

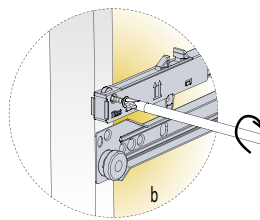

Screw the Titusoft mechanism to the face frame

3.

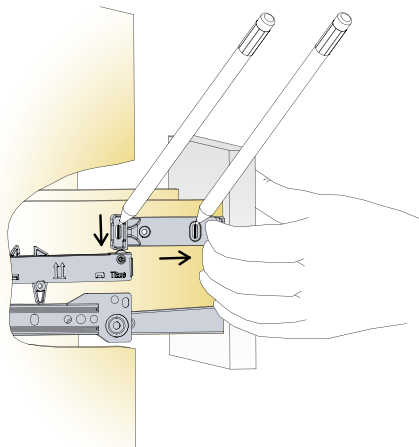

Align the activator with the top of the Titusoft mechanism and fix with two screws

4.

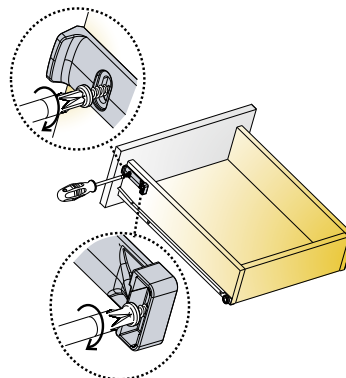

Fix with 2 (3) screws L=12mm

A trial mounting is always recommended. Please contact Titus Group or your local distributor for further technical assistance.

Titusoft SD100s

Add-on Damper for Set 200

For bottom running sliding door systems

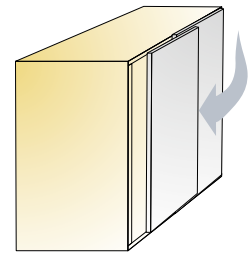

Titusoft SD100s



Technical details

Released position

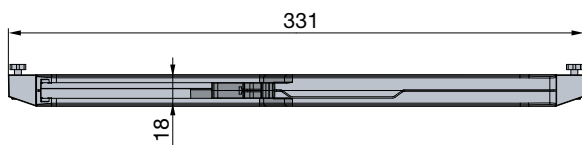
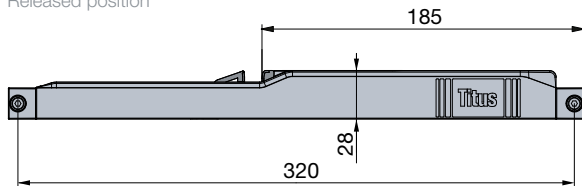

Drawings show example with components presented above

Item number

973-9060 →

Grey

380

The system consists of the following components

Quantity for 2-door cabinet

Standard component

Titusoft SD100s mechanism



2 pcs

Customized components to suit the customer's sliding door system

Attachment base



4 pcs

Nut



4 pcs

Screw M4 x 16



4 pcs



Activator and attachments on this page suit Set200.
We offer a customer dedicated design as per its requirements
→ contact Titus Group representative for more information



25 sets

- Non-handed design
- Effortless door opening with low pull-out force
- Efficient damping on different door sizes
- Slim design for concealed application

Titusoft SD100s capacity

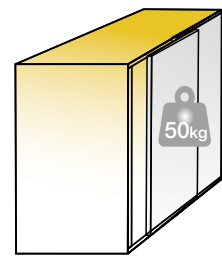

Up to 50kg per door



Set 200
→ see page 4.37

Mounting details

Non-handed design

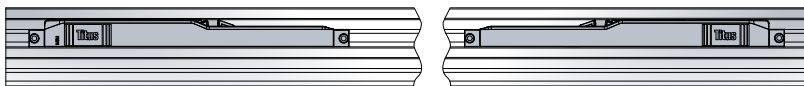

Mount Titusoft SD100s on top rail on both sides of the cabinet.
(1 pc Titusoft SD100s per 1 door)

Mounting position

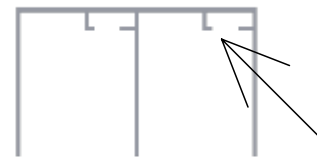

Titusoft SD100s is mounted into the top profile

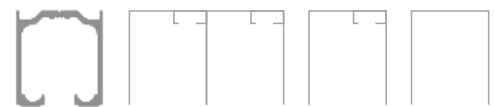

Fit various U and double U shaped profiles

Space requirements



Slim design with 30mm height allows for concealed application

Titusoft SD100

Add-on Damper for Sliding Door

For top running sliding door systems

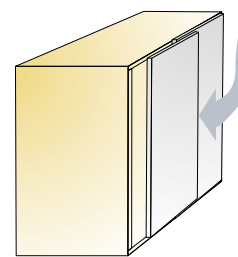

Titusoft SD100

Item number

973-9018 →

Grey

380



The system consists of the following components

Quantity for 2 door cabinet

Standard component

Titusoft SD100 mechanism

2 pcs



Customized components to suit the customer's sliding door system

Base

4 pcs



Stopper

2 pcs



Activator for internal door

1 pc



Activator for external door

1 pc



Accessories

Screws

Countersunk screw D4x40mm

4 pcs

Countersunk screw D4x25mm

4 pcs

Chipboard screw Ø4x16mm

3 pcs

Eurocrew Ø6.3x15mm

2 pcs

Mounting instructions

1 pc



Technical details

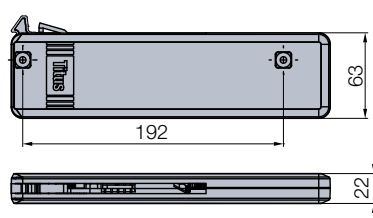

Drilling details

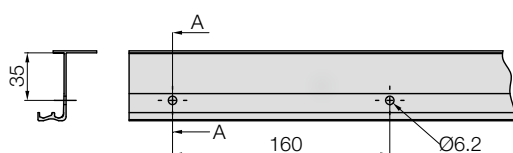

 32 Sets

- ConfidentClose
- Intuitive mounting
- Non-handed design
- Efficient damping on different door sizes
- Smooth and controlled closing motion

Titusoft SD100 capacity

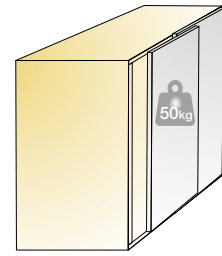

Up to 50kg per door

Mounting details

Non-handed design

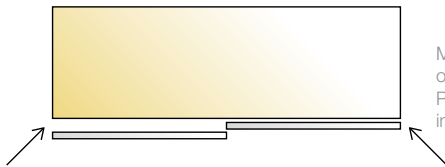

Mount Titusoft SD100 on top rail on both sides of the cabinet. Please follow mounting instructions included in a set.

Mounting positions

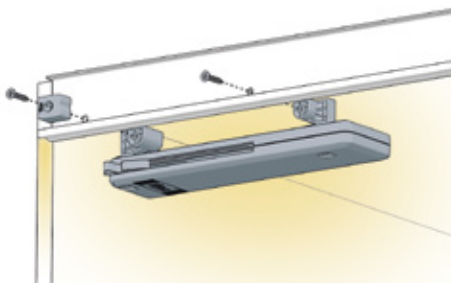

Titusoft SD100 mechanism position

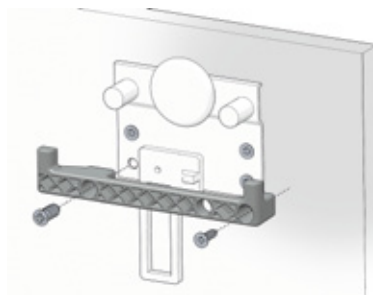

* Activator for internal door position

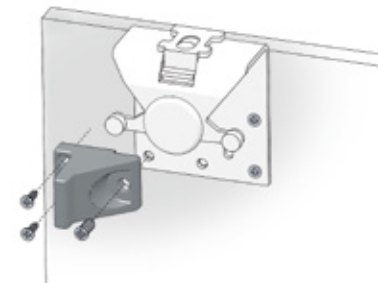

* Activator for external door position



Click to engage

distrib

For further information please contact your Titus Group representative.

Sliding Door Solutions for Bottom Running Door Information

Introduction

Application

For built-in cabinets
Walk-in closets
Room-dividers
Wardrobes

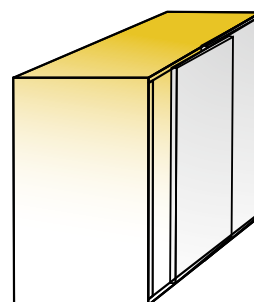

For 2 and 3 door
applications



Load capacity

Maximum door weight is 50 kg

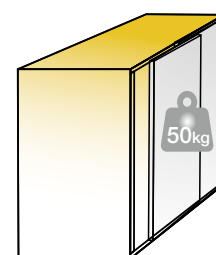

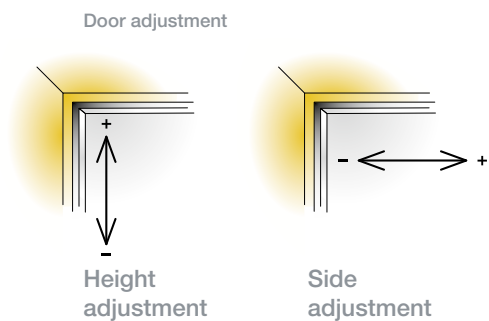

Adjustments

Height adjustment

Height adjustment is done through the adjustment screw on the bottom carriage

Adjustment range depends on the preset position. Carriage is factory preset to the lowest value.

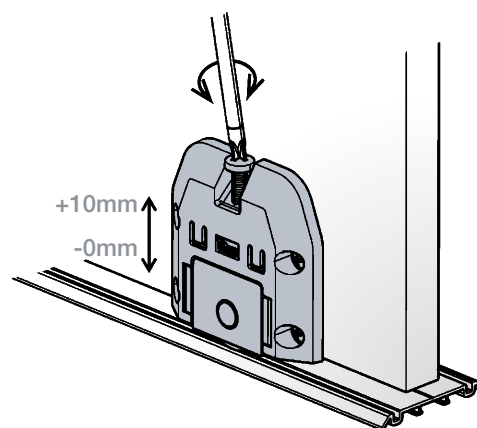
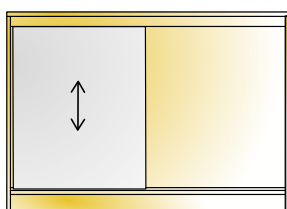

Side adjustment

Side adjustment is done through stopper position.

The adjustment defines the gap between doors and cabinet side/wall

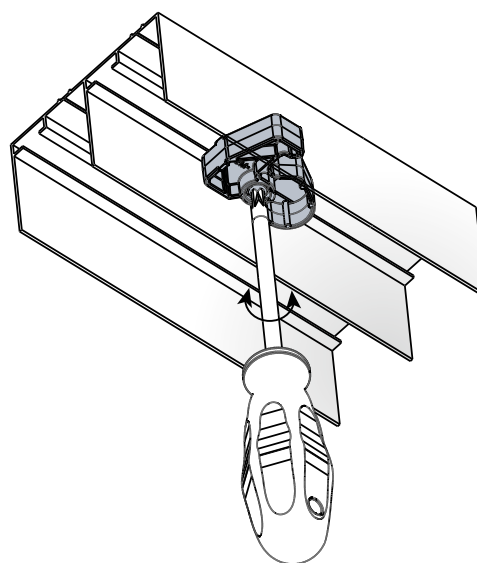
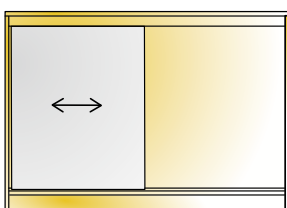







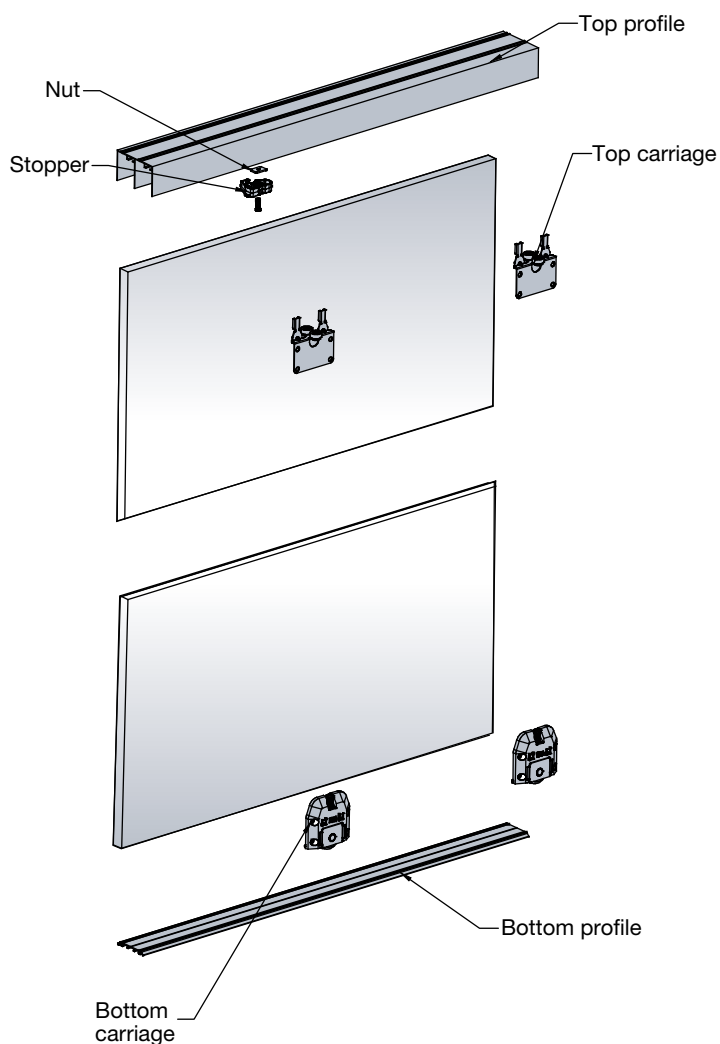
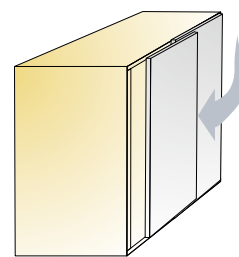

Stopper limits and stops the motion of the cabinet door

Set 200

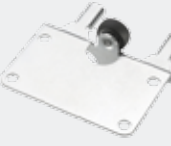
Sliding Door Mechanism

For bottom running sliding door systems



Item number for set	Set for 2-doors	Set for 3-doors
610-9691-380 →	K1	K2
Set consists of the following components		
Bottom carriages 	4 pcs	6 pcs
Top carriages 	4 pcs	6 pcs
Pan head screws 	32 pcs	48 pcs
Stopper 	4 pcs	6 pcs
Nut for stopper 	4 pcs	6 pcs
Screw M4 x 16 for stopper 	4 pcs	6 pcs
Self adhesive tape	5 pcs	5 pcs
Mounting instructions 	1 pc	1 pc

 20 sets

 Rails and accessories are not included in the set and can be ordered separately

Rails

 Top rail
→ see page 4.39

 Bottom rail
→ see page 4.39

Accessories

 Titusoft SD100s
→ see page 4.31

- Door weight max. 50kg
- Door thickness 18-22mm
- Door material wood (chipboard, MDF, solid wood)

Mounting details

Door drilling pattern

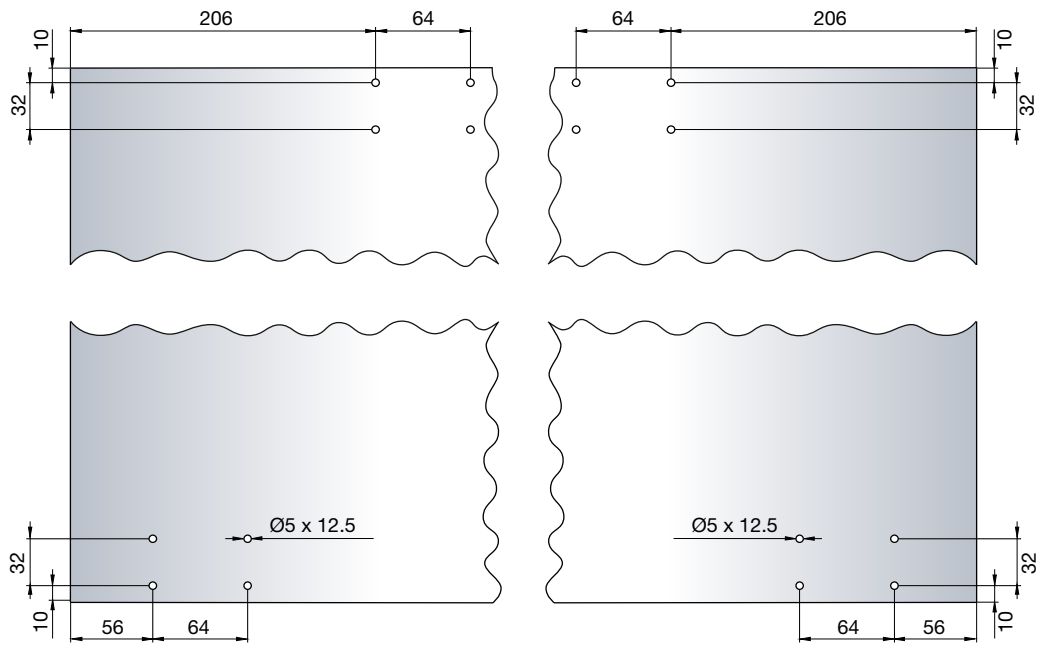
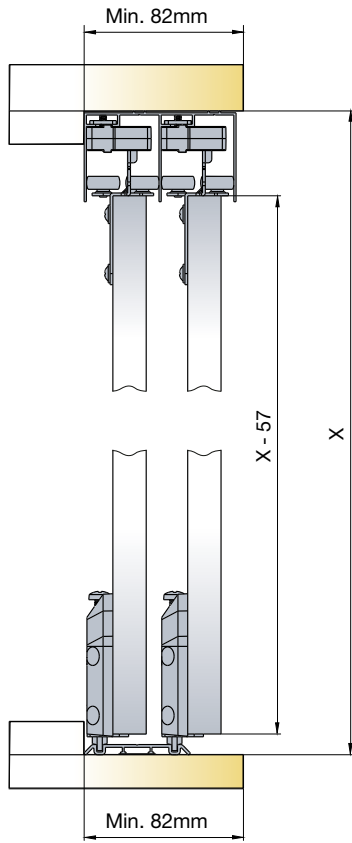

X = space available between top and bottom panel
 X - 57 = door height







Top and bottom carriage drilling positions

Rails

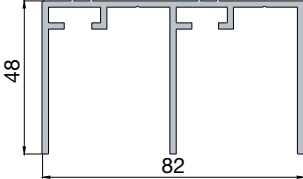
For Set 200

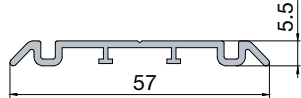

Screws for top rail are not supplied and depend on the application (cabinet, built-in cabinet).
Bottom rail is fixed with self-adhesive tape.
Rail is pre-drilled and ready to install.

		Rail length	Item number
<p>Top rail</p>  <p>Technical details</p> 	2000	610-9692-070-K1	
	2400	610-9693-070-K1	
	3000	610-9694-070-K1	
			<i>*other lengths upon special request</i>
Set consists of:			
<p>Bottom rail</p>  <p>Technical details</p> 	<p>Top rail</p> 	1 pc	
	<p>Bottom rail</p> 	1 pc	
 5 sets			

The Titus Group Profile

Titus Group

Titus focuses on the design, manufacture and distribution of connectors, concealed hinges drawers and soft closing mechanisms in furniture and household appliances.

Titus Group is owned and managed from its headquarters in United Kingdom. We are able to provide products and services to every customer around the world based on manufacturing and distribution facilities in Europe, North America, China, SE Asia, Australia and New Zealand.

Quickfit technology makes Titus the World leader in connectors for RTA furniture

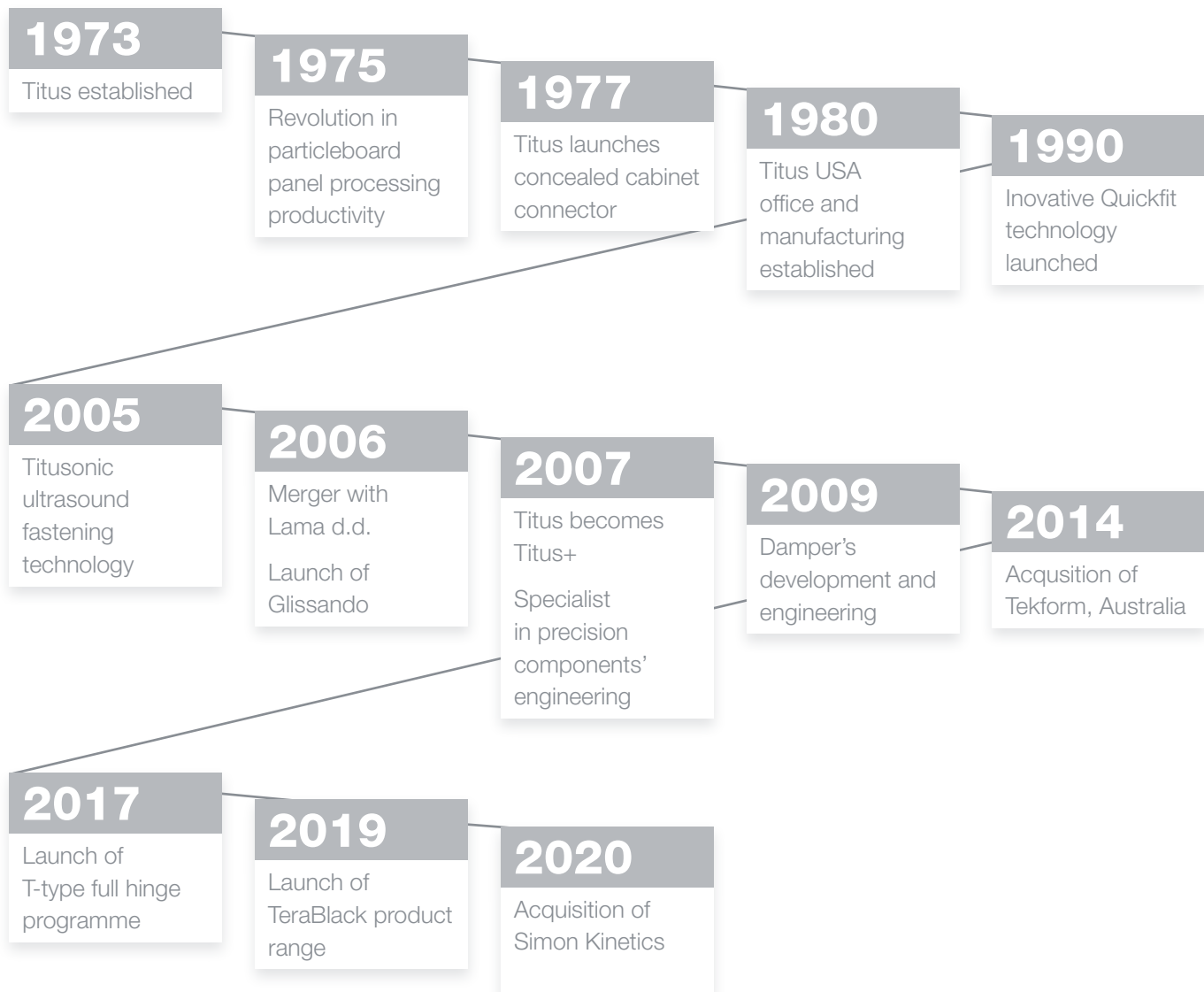

Vision

The world's best engineering for precision components

Mission

To provide manufacturers with components' solutions that improve competitiveness

Titus Business Philosophies and Principles

- Gain total knowledge of our customers and their markets
- Focus on identifying and creating high volume component niches
- Meet our customers' expectations with global consistency
- Build long term associations with customers, suppliers, colleagues and shareholders
- Invest in the abilities of individuals at every level
- Continuously enhance input efficiency and sustainability

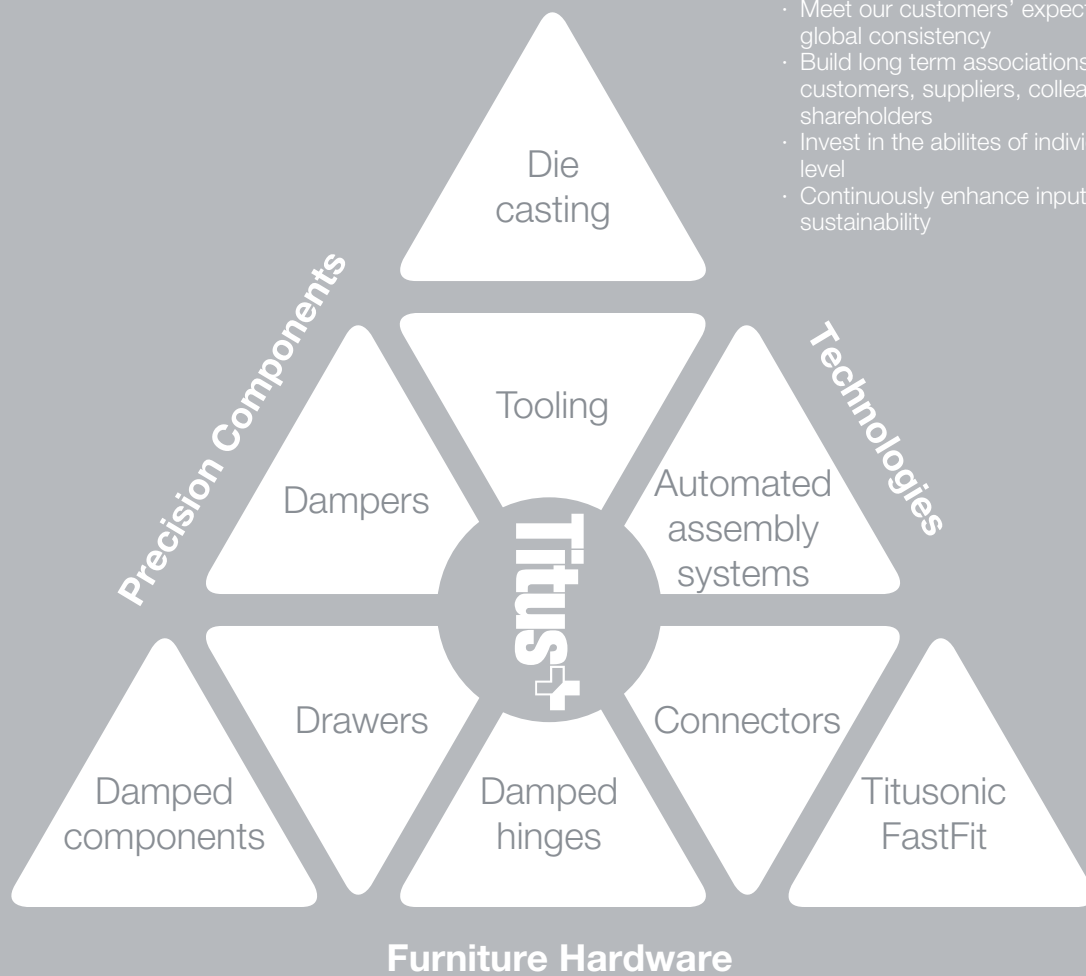

Furniture Hardware

- Cabinet connectors
- Concealed hinges
- Soft closing systems
- Drawers and drawer systems
- Kitchen accessories
- RV hardware

Components

- Hydraulic dampers
- Precision components
- Precision die castings
- Damped mechanisms

Technologies

- Automated assembly systems
- Die casting technologies
- Tooling
- Titusonic - Ultrasound fastening
- FastFit technology

'Totally Integrated Engineering'

Product Design

Design and engineering of unique components
Consistent and repeatable product quality

Manufacturing Technologies

To improve productivity and product quality

Manufacturing Operations

A wide array of technologies and services required for high volume production of precision components available in-house

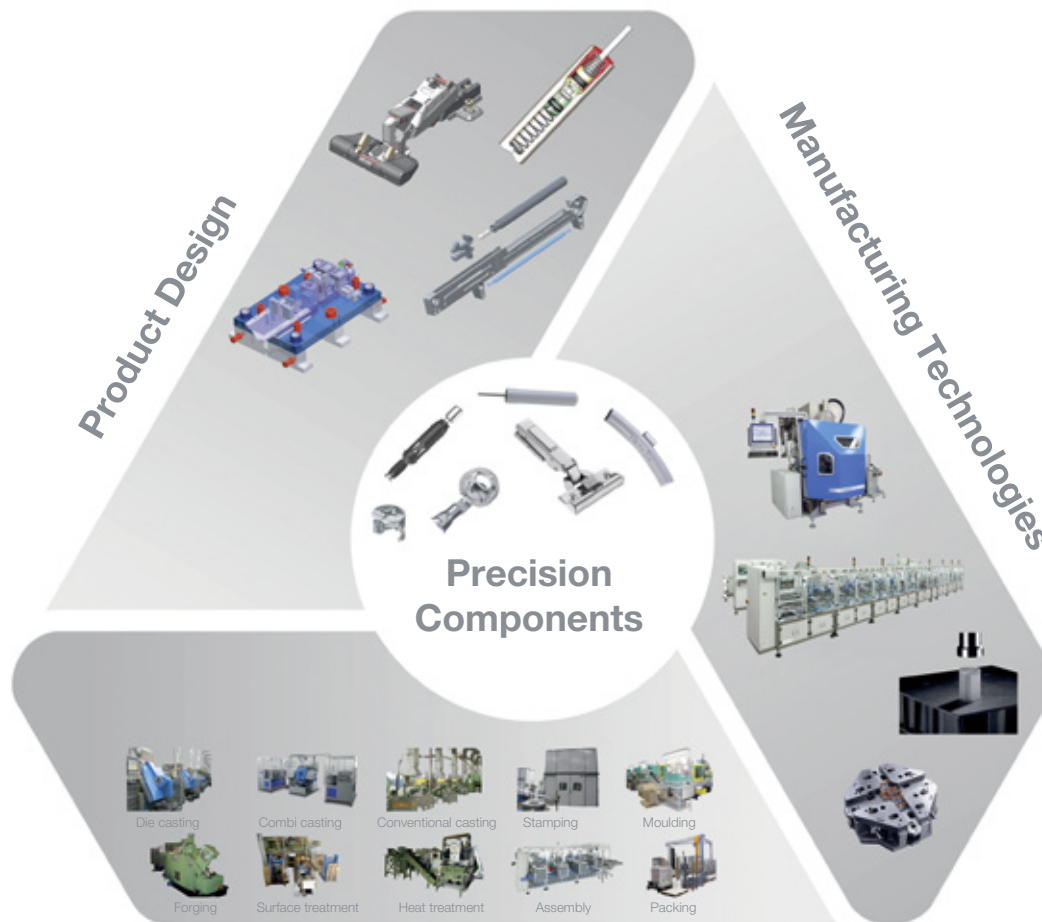

Manufacturing Operations

Fittings for purpose

Unique product advantages for better value for money and lower 'total installed cost'

Innovations that improve

With less parts, less different parts, less preparation actions, faster assembly

Fast time-to-market

Quality

Continuous Improvement

The Titus Group Mission, to improve the competitiveness of our customers, encourages us to continuously improve our products, services, processes and competencies of our employees.

Quality

We believe that the Titus Mission is achieved most effectively through the management of our design, manufacturing and service activities in conformance with the ISO 9001 standard for quality management. Quality has a broad meaning for us: it is our guide to the selection of materials, work, processes, internal relations and cooperation with partners.

Products

Our integrated quality system produces technically optimized products of high quality. They are assessed regularly in our own test labs as well as by internationally renowned institutions, such as LGA from Germany, CTBA from France, FIRA from United Kingdom, CATAS from Italy, AIDIMA from Spain, and others.

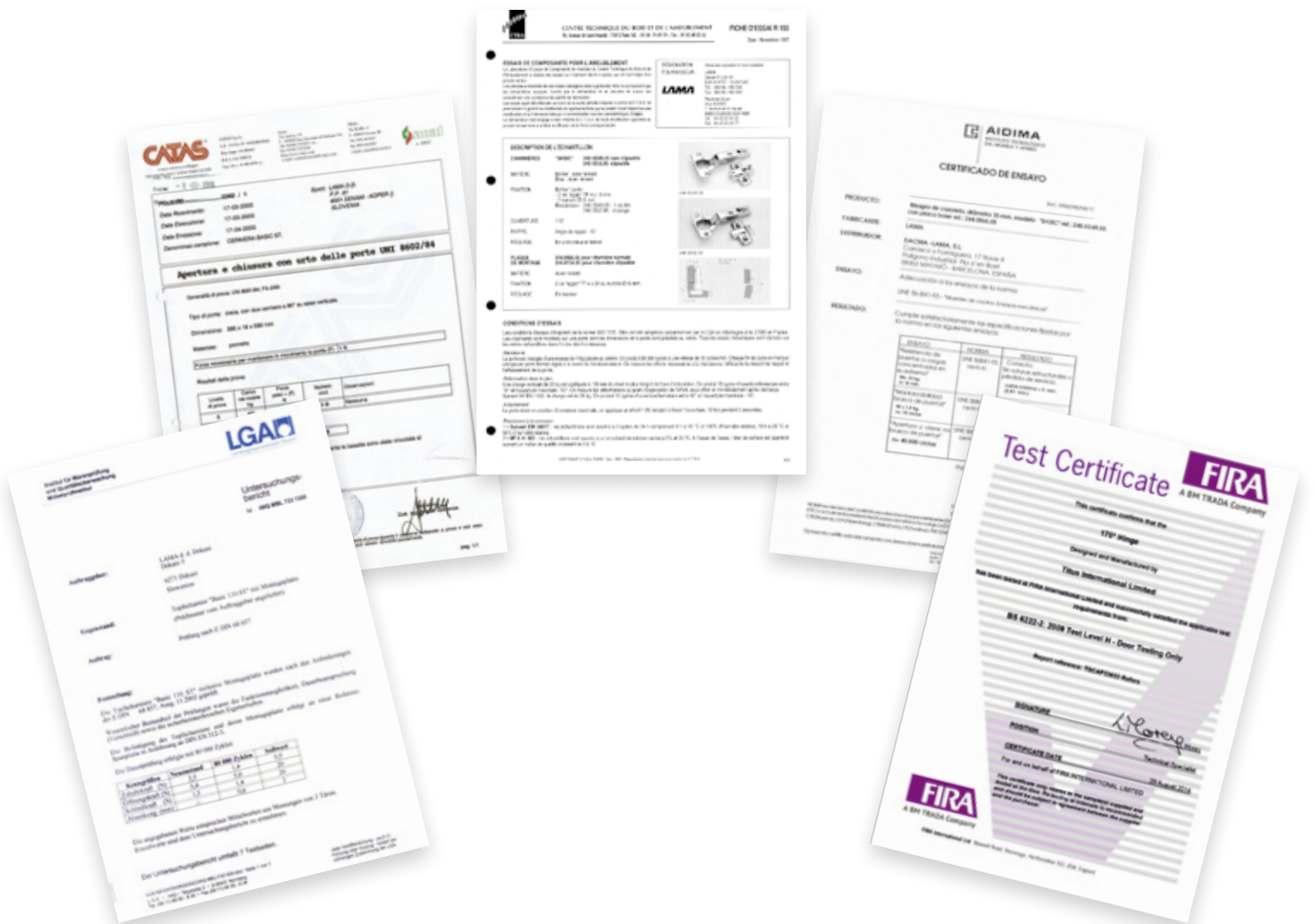

Worldwide Design, Manufacturing and Distribution Capabilities

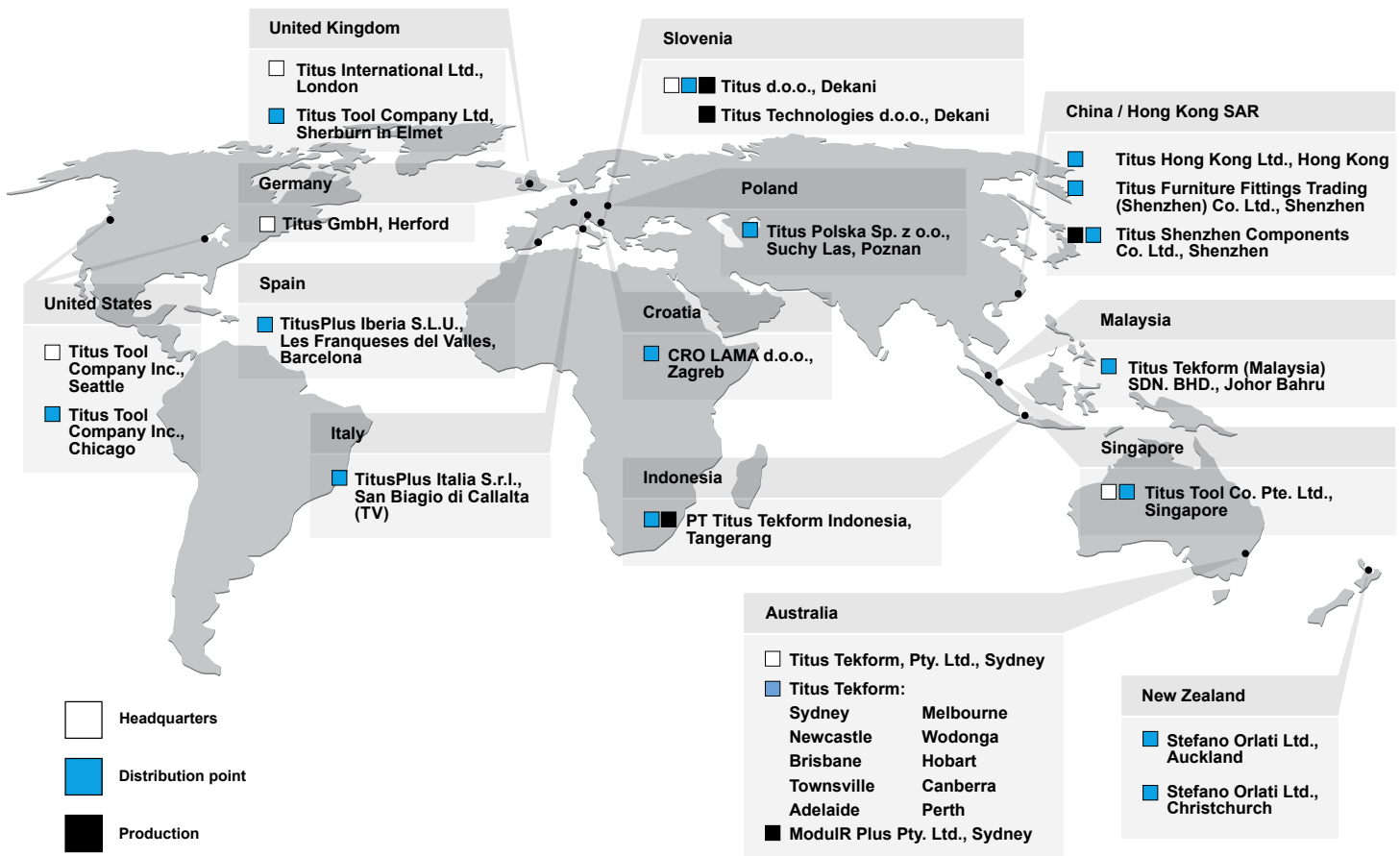

Europe

Titus d.o.o. Dekani
 Dekani 5
 SI-6271 Dekani
 Slovenia
 +386 5 6690 101
 +386 5 6690 205 Fax
 info@titusplus.com

Titus Technologies d.o.o.
 Dekani 5
 SI-6271 Dekani
 Slovenia
 +386 5 6690 000
 technologies@titusplus.com

Titus Tool Company Ltd.
 10 Blackburn Industrial Estate
 Enterprise Way
 Sherburn in Elmet
 LS256NA
 United Kingdom
 +44 1977 682582
 +44 1977 680481 Fax
 uk@titusplus.com

CRO LAMA d.o.o.
 Kreše Golika 3
 HR-10000 Zagreb
 Croatia
 +385 1 3323 033
 +385 1 3323 233 Fax
 croatia@titusplus.com

ul. Stefańskiego 17 A
 PL-62-002 Suchy Las/Poznań
 Poland
 +48 61 811 5402 Phone/Fax
 +48 61 811 5684 Phone/Fax
 +48 61 821 9362
 poland@titusplus.com

TitusPlus Italia S.r.l.
 Via Aquileia 9
 Frazione Olmi
 IT-31048 San Biagio di Callalta (TV)
 Italy
 +39 04 221 650 120
 +39 04 221 650 136 Fax
 italia@titusplus.com

TitusPlus Iberia S.L.U.
 C/ Luxemburg 16
 ES-08520 Les Franqueses del Valles
 (Barcelona)
 Spain
 +34 938 715 404
 +34 938 605 498 Fax
 iberia@titusplus.com

Titus GmbH, Herford
 Lübberlindenweg 12
 DE-32049 Herford
 Germany
 + 49 5221 102488-0
 germany@titusplus.com

Titus Tool Company Inc.
 2800 156th Avenue SE
 Suite 135
 Bellevue, WA 98007
 USA
 +1 800 762 1616 Toll free
 +1 425 746 2080
 +1 425 746 2344 Fax

Titus Tool Company Inc.
 11056 W. Addison Street
 Franklin Park, IL 60131
 USA
 +1 800 762 1616 Toll free
 +1 425 746 2080
 +1 425 746 2344 Fax
 usa@titusplus.com

Australia and New Zealand

Titus Tekform Pty Ltd
 83 Jemma Road
 Prestons NSW 2170
 Australia
 +61 2 9286 0007
 +61 2 9826 0074 Fax
 www.titustekform.com.au
 info@titustekform.com.au

Stefano Orlati Ltd
 34 Waipareira Avenue
 Henderson
 Auckland
 New Zealand
 +64 9 837 0886
 +64 9 837 8003 Fax
 www.stefano-orlati.co.nz
 stefano-orlati@titusplus.com

Titus Tool Co. Pte. Ltd.
 5004 Ang Mo Kio Ave 5
 Techplace II #04-01
 Singapore 569872
 Singapore
 +65 6383 3922
 +65 6383 3178 Fax
 singapore@titusplus.com

Titus (Shenzhen) Components Co. Ltd.
 1st Floor Building No. 2
 Heng Changrong High-tech Industrial Park
 ShangNan South Road
 Shangjin Street
 Baoan District Shenzhen Province
 China
 +86 755 8348 0916
 +86 8359 2676 Fax
 china@titusplus.com

Titus Tekform Indonesia, PT
 Taman Teknoblok L2 No. 7
 Bumi Serpong Damai Sektor XI
 15314 Tangerang
 Indonesia
 +62 21 75873578
 +62 21 75873574 Fax
 indonesia@titusplus.com

Headquarters

Titus International Ltd
 28 Fitzroy Square
 London
 W1T 6DD
 United Kingdom
 info@titusplus.com

www.titusplus.com
 info@titusplus.com

Titus Polska Sp. z o.o.

America

Asia

Index

Item number	Page
0435	1.57
0436	1.57
00021	1.19
00022	1.19
00033	1.73
00180	1.10
01029	1.43
01373	1.72
01709	1.12
01732	1.12
01822	1.63
01823	1.63
01825	1.63
01828	1.63
01829	1.63
01837	1.63
01838	1.63
01843	1.63
01852	1.63
01910	1.65
01911	1.65
01912	1.64
01916	1.65
02075	1.13
02077	1.13
02107	1.20
02110	1.68
02111	1.68
02120	1.20
02130	1.20
02133	1.68
02139	1.20
02141	1.20
02144	1.20
02154	1.67
02161	1.19
02190	1.19
02193	1.19
02523	1.72
02549	1.71
02558	1.69
02559	1.69
02560	1.69
02569	1.71
02570	1.71
02571	1.71
02574	1.71
02575	1.70
02578	1.72
02579	1.70
02582	1.70
02630	1.69
02634	1.72

Item number	Page
02642	1.70
02648	1.71
02653	1.71
02663	1.70
02666	1.71
02669	1.70
02671	1.70
02672	1.70
02699	1.71
02706	1.71
02710	1.72
02985	1.12
03090	1.16
03118	1.16
03121	1.16
03150	1.16
03168	1.16
03180	1.16
03181	1.16
05050	1.34
05052	1.34
05147	1.34
05270	1.34
05282	1.39
05314	1.33
05366	1.33
05380	1.38
05388	1.33
05409	1.57
05410	1.57
05414	1.35
05453	1.33
05474	1.33
05503	1.33
05552	1.34
05554	1.34
05556	1.34
05563	1.34
05592	1.38
05608	1.40
05609	1.40
05610	1.40
05611	1.40
05753	1.38
05751	1.38
05752	1.38
05757	1.38
05772	1.38
05774	1.38
05775	1.38
05778	1.38
05857	1.38
05858	1.38

Item number	Page
05859	1.38
05860	1.39
05917	1.58
05929	1.38
05960	1.58
05971	1.58
06073	1.13
06308	1.73
06309	1.73
06310	1.73
06343	1.55
06348	1.55
06381	1.54
06383	1.54
06385	1.54
06387	1.54
06395	1.52
06397	1.52
06401	1.48
06402	1.48
06403	1.48
06405	1.48
06406	1.48
06408	1.47
06410	1.47
06411	1.50
06412	1.50
06413	1.49
06414	1.49
06415	1.50
06416	1.49
06431	1.51
06433	1.51
06435	1.51
06437	1.51
06439	1.52
06441	1.52
06443	1.52
06445	1.52
06447	1.51
06449	1.51
06451	1.51
06453	1.51
06455	1.52
06457	1.52
06459	1.52
06461	1.52
06464	1.53
06465	1.53
06470	1.53
06471	1.53
06472	1.53
06473	1.53

Item number	Page
06479	1.47
06495	1.48
06802	1.18
06803	1.18
06806	1.18
06839	1.18
09406	1.42
09423	1.36
09424	1.36
09430	1.37
09435	1.36
09443	1.36
09456	1.36
09491	1.42
09583	1.36
09588	1.36
09592	1.36
09594	1.36
09597	1.37
09631	1.42
09651	1.32
09652	1.32
09690	1.41
09692	1.41
09695	1.41
09699	1.41
974-4757	1.21
275-4035	1.59
275-4058	1.59
277-4225	1.43
277-4355	1.43
279-9187	1.21
241-0043-650	2.171
241-0050-650	2.171
248-0V62-050	2.89
242-0824-650	2.95
242-0885-650	2.93
242-0886-650	2.93
242-0924-650	2.137
242-0967-054	2.135
242-0968-054	2.135
242-0970-054	2.87
242-0971-054	2.87
242-0973-054	2.135
242-0974-054	2.135
242-0976-054	2.87
242-0977-054	2.87
242-0979-054	2.135
242-0980-054	2.135
242-0997-054	2.87
242-0998-054	2.87
242-0C27-650	2.139
242-0D14-650	2.139

Index

Item number	Page	Item number	Page	Item number	Page	Item number	Page
242-0H17-650	2.97	244-0810-650	2.143, 2.153	244-0930-050	2.168	248-0G52-050	2.147
242-0H34-650	2.137	244-0813-650	2.153	244-0965-050	2.168	248-0G53-050	2.153
242-0H48-650	2.141	244-0846-050	2.173	244-1228-050	2.130	248-0G54-050	2.145
242-0H49-650	2.141	244-0848-650	2.171	244-1229-050	2.130	248-0G55-050	2.145
242-0P81-650	2.95	244-0907-650	2.171	244-1233-050	2.130	248-0G56-050	2.145
242-0W48-650	2.91	244-0B12-650	2.168	244-1234-050	2.130	248-0G57-050	2.147
242-0W71-650	2.89	244-0C32-650	2.143, 2.153	244-1136-050	2.130	248-0G58-050	2.153
242-0W72-650	2.89	244-0D46-650	2.171	244-1137-050	2.130	248-0G79-050	2.145
242-0G76-650	2.97	244-0D47-650	2.171	244-1138-050	2.130	248-0G80-050	2.145
242-0Y45-650	2.99	244-0D99-650	2.171	244-1139-050	2.130	248-0G81-050	2.145
242-0Y46-650	2.99	244-0E02-650	2.171	244-1645-050	2.130	248-0G82-050	2.147
242-0Y48-650	2.143	244-0G19-050	2.168	244-3016-650	2.130	248-0G83-050	2.153
242-0Y49-650	2.143	244-0H64-050	2.168	244-3600-650	2.132	248-0K10-050	2.173
244-0036-650	2.170	244-0H65-050	2.168	244-3603-650	2.132	248-0K40-050	2.145
244-0062-650	2.168	244-0K95-050	2.168	244-3651-650	2.130	248-0K76-050	2.145
244-0063-650	2.168	244-0K96-050	2.168	244-3653-650	2.132	248-0L04-050	2.145
244-0067-650	2.168	244-0K97-650	2.168	244-3654-650	2.132	248-0L27-650	2.149
244-0068-650	2.168	244-0K98-650	2.168	244-3655-650	2.132	248-0L28-050	2.151
244-0085-650	2.130	244-0L26-050	2.168	248-0080-050	2.105	248-0L32-650	2.149
244-0095-650	2.130	244-0L29-050	2.168	248-0160-050	2.161	248-0L33-050	2.151
244-0118-050	2.130	244-0L37-650	2.168	248-0161-050	2.161	248-0L46-050	2.151
244-0119-050	2.130	244-0L38-650	2.168	248-0162-050	2.123	248-0L51-050	2.159
244-0120-050	2.130	244-0L39-050	2.168	248-0163-050	2.123	248-0L61-050	2.115
244-0134-050	2.130	244-0L40-050	2.168	248-0171-050	2.101	248-0L70-050	2.151
244-0135-050	2.130	244-0L50-050	2.168	248-0172-050	2.101	248-0L71-050	2.149
244-0136-050	2.130	244-0L98-050	2.168	248-0186-050	2.101	248-0L72-050	2.147
244-0137-050	2.130	244-0M28-650	2.168	248-0188-050	2.101	248-0L73-050	2.153
244-0166-050	2.130	244-0M29-650	2.168	248-0255-050	2.153	248-0M41-050	2.171
244-0167-050	2.130	244-0M33-650	2.130	248-0279-050	2.101	248-0M73-050	2.121
244-0175-650	2.168	244-0P24-050	2.168	248-0280-050	2.101	248-0N12-050	2.109
244-0232-650	2.168	244-0P25-050	2.168	248-0283-050	2.113	248-0N13-050	2.109
244-0258-050	2.128	244-0P26-050	2.130	248-0285-050	2.113	248-0N16-050	2.111
244-0259-050	2.128	244-0P27-050	2.130	248-0327-050	2.101	248-0N17-050	2.111
244-0260-050	2.128	244-0P28-650	2.143, 1.153	248-0328-050	2.101	248-0N20-050	2.113
244-0261-050	2.128	244-0P29-650	2.130	248-0431-050	2.111	248-0N21-050	2.113
244-0262-050	2.128	244-0P41-650	2.168	248-0433-050	2.111	248-0N24-050	2.115
244-0263-050	2.128	244-0S65-050	2.168	248-0482-050	2.101	248-0N25-050	2.115
244-0264-050	2.128	244-0S66-050	2.168	248-0487-050	2.101	248-0N38-050	2.149
244-0265-050	2.128	244-0S67-050	2.168	248-0532-050	2.101	248-0N62-050	2.115
244-0266-050	2.128	244-0S68-050	2.168	248-0533-050	2.101	248-0P43-050	2.159
244-0270-050	2.128	244-0T14-650	2.168	248-0534-050	2.101	248-0R09-050	2.173
244-0271-050	2.128	244-0T28-050	2.168	248-0535-050	2.101	248-0R10-050	2.159
244-0272-050	2.128	244-0T40-050	2.168	248-0536-050	2.101	248-0R12-050	2.159
244-0342-050	2.128	244-0V19-050	2.130	248-0537-050	2.101	248-0R13-050	2.121
244-0343-050	2.128	244-0V50-050	2.170	248-0545-050	2.101	248-0R14-050	2.121
244-0344-050	2.128	244-0V64-050	2.168	248-0547-050	2.101	248-0R17-050	2.121
244-0561-050	2.130	244-0Z26-050	2.130	248-0665-050	2.109	248-0T80-050	2.163
244-0562-050	2.130	244-0Z51-050	2.130	248-0675-050	2.109	248-0T81-050	2.163
244-0565-050	2.130	244-0Z63-050	2.130	248-0742-050	2.115	248-0U13-050	2.163
244-0566-050	2.130	244-0866-050	2.168	248-0745-050	2.115	248-0U14-050	2.163
244-0567-050	2.130	244-0867-050	2.168	248-0G49-050	2.145	248-0U16-050	2.125
244-0568-050	2.130	244-0914-650	2.168	248-0G50-050	2.145	248-0U21-050	2.125
244-0655-050	2.173	244-0929-050	2.168	248-0G51-050	2.145	248-0U22-050	2.125

Index

Item number	Page
248-0V14-050	2.103
248-0V15-050	2.125
248-0V18-050	2.107
248-0V39-050	2.103
248-0V41-050	2.103
248-0V42-050	2.103
248-0V45-050	2.107
248-0V47-050	2.107
248-0V48-050	2.107
248-0V62-050	2.105
248-0V66-050	2.153
248-1646	2.177
248-1712	2.177
248-4668	2.175
248-4672	2.175
338-3686	1.64
338-3687	1.64
338-9721	1.64
353-3649	1.67
353-3650	1.67
360-1222	1.66
360-1230	1.66
408-3166	1.59
408-3391	1.59
408-3423	1.59
408-3424	1.59
610-9691-380	4.35
610-9692-070-K1	4.37
610-9693-070-K1	4.37
610-9694-070-K1	4.37
655-7H60	3.50
655-7H80	3.50
655-7L60	3.50
655-7L80	3.50
655-7M60	3.50
655-7M80	3.50
655-7P40	3.17
655-7P45	3.17
655-7P50	3.17
655-7S40	3.27
655-7S45	3.27
655-7S50	3.27
655-7T40	3.33
655-7T45	3.33
655-7T50	3.33
655-7U40	3.17
655-7U45	3.17
655-7U50	3.17
655-7W40	3.27
655-7W45	3.27
655-7W50	3.27
655-7X40	3.33
655-7X45	3.33

Item number	Page
655-7X50	3.33
655-8E27	3.13
655-8E30	3.13
655-8E35	3.13
655-8E40	3.13
655-8E45	3.13
655-8E50	3.13
655-8E55	3.13
655-8E61	3.15
655-8E62	3.15
655-8E63	3.15
655-8E64	3.15
655-8F27	3.19
655-8F30	3.19
655-8F35	3.19
655-8F40	3.19
655-8F45	3.19
655-8F50	3.19
655-8F55	3.19
655-8F61	3.21
655-8F62	3.21
655-8F63	3.21
655-8F64	3.21
655-8G27	3.23
655-8G30	3.23
655-8G35	3.23
655-8G40	3.23
655-8G45	3.23
655-8G50	3.23
655-8G55	3.23
655-8G61	3.25
655-8G62	3.25
655-8G63	3.25
655-8G64	3.25
655-8H27	3.29
655-8H30	3.29
655-8H35	3.29
655-8H40	3.29
655-8H45	3.29
655-8H50	3.29
655-8H55	3.29
655-8H61	3.31
655-8H62	3.31
655-8H63	3.31
655-8H64	3.31
655-8T27	3.13
655-8T30	3.13
655-8T35	3.13
655-8T40	3.13
655-8T45	3.13
655-8T50	3.13
655-8T55	3.13
655-8T61	3.15

Item number	Page
655-8T62	3.15
655-8T63	3.15
655-8T64	3.15
655-8U27	3.19
655-8U30	3.19
655-8U35	3.19
655-8U40	3.19
655-8U45	3.19
655-8U50	3.19
655-8U55	3.19
655-8U61	3.21
655-8U62	3.21
655-8U63	3.21
655-8U64	3.21
655-8V27	3.23
655-8V30	3.23
655-8V35	3.23
655-8V40	3.23
655-8V45	3.23
655-8V50	3.23
655-8V55	3.23
655-8V61	3.25
655-8V62	3.25
655-8V63	3.25
655-8V64	3.25
655-8Z27	3.29
655-8Z30	3.29
655-8Z35	3.29
655-8Z40	3.29
655-8Z45	3.29
655-8Z50	3.29
655-8Z55	3.29
655-8Z61	3.31
655-8Z62	3.31
655-8Z63	3.31
655-8Z64	3.31
655-8064	3.35, 3.39 3.43
655-8065	3.35
655-8085	3.37, 3.41, 3.45
655-8090	3.39, 3.43
655-8096	3.41
655-8097	3.41
655-8098	3.41
655-8101	3.39
655-8103	3.41
655-8016	3.49
655-8017	3.49
655-8018	3.49
655-8165	3.45
655-8166	3.45
655-8167	3.45
655-8170	3.43

Item number	Page
655-8172	3.45
655-8220	3.41
655-8221	3.41
655-8222	3.41
655-8295	3.37
655-8296	3.37
655-8297	3.37
655-8300	3.37
655-8301	3.37
655-8302	3.37
655-8305	3.37
655-8280	3.45
655-8281	3.45
655-8282	3.45
655-9152	3.47
700-0KA0-054	2.82
700-0KA1-054	2.82
700-0KA2-054	2.82
700-0KA3-054	2.82
700-0KA4-054	2.82
700-0KB0-054	2.82
700-0KB1-054	2.82
700-0KB2-054	2.82
700-0KB3-054	2.82
700-0KB4-054	2.82
700-0KC0-054	2.82
700-0KC1-054	2.82
700-0KC2-054	2.82
700-0KC3-054	2.82
700-0KC4-054	2.82
700-0KE0-054	2.82
700-0KE1-054	2.82
700-0KE2-054	2.82
700-0KE3-054	2.82
700-0KE4-054	2.82
700-0KF0-054	2.82
700-0KF1-054	2.82
700-0KF2-054	2.82
700-0KF3-054	2.82
700-0KF4-054	2.82
700-0KW0-054	2.84
700-0KW3-054	2.84
700-0LB0-650	2.82
700-0LB2-650	2.82
700-0LB3-650	2.82
700-0LC0-650	2.82
700-0LC2-650	2.82
700-0LC3-650	2.82
700-0LF0-650	2.82
700-0LF2-650	2.82
700-0LF3-650	2.82
700-0NA0-054	2.84
700-0NA1-054	2.84

Index

Item number	Page	Item number	Page	Item number	Page	Item number	Page
700-0NA2-054	2.84	701-0D64-650	2.33	702-0BK1-054	2.51	702-0GL1-054	2.77
700-0NA3-054	2.84	701-0D66-650	2.33	702-0BK4-054	2.51	702-0GL4-054	2.77
700-0NA4-054	2.84	701-0D70-650	2.33	702-0C53-650	2.61	702-0UK0-054	2.65
700-0NB0-054	2.84	701-0D72-650	2.33	702-0C55-650	2.61	702-0UK1-054	2.65
700-0NB1-054	2.84	701-0D76-650	2.33	702-0C77-650	2.61	702-0UK4-054	2.65
700-0NB2-054	2.84	701-0D78-650	2.33	702-0C79-650	2.61	702-0ULO-054	2.65
700-0NB3-054	2.84	701-0D82-650	2.37	702-0CK0-054	2.53	702-0UL1-054	2.65
700-0NB4-054	2.84	701-0D84-650	2.37	702-0CK1-054	2.53	702-0UL4-054	2.65
700-0NC0-054	2.84	701-0D88-650	2.37	702-0CK4-054	2.53	704-0553-054	2.71
700-0NC1-054	2.84	701-0D90-650	2.37	702-0CL0-054	2.53	704-0593-054	2.71
700-0NC2-054	2.84	701-0D98-650	2.37	702-0CL1-054	2.53	704-0595-054	2.73
700-0NC3-054	2.84	702-0DK0-054	2.53	702-0CL4-054	2.53	704-0604-054	2.71
700-0NC4-054	2.84	702-0DK1-054	2.53	702-0D29-650	2.63	704-0661-054	2.71
700-0NE0-054	2.84	702-0DK4-054	2.53	702-0D31-650	2.63	704-0672-054	2.71
700-0NE1-054	2.84	701-0DS0-054	2.31	702-0D35-650	2.63	704-0673-054	2.71
700-0NE2-054	2.84	701-0DS1-054	2.31	702-0D37-650	2.63	704-0674-054	2.73
700-0NE3-054	2.84	701-0DS4-054	2.31	702-0D63-650	2.55	704-0697-054	2.73
700-0NE4-054	2.84	701-0DT0-054	2.31	702-0D65-650	2.55	707-0WK0-054	2.69
700-0NF0-054	2.84	701-0DT1-054	2.31	702-0D69-650	2.55	707-0WK1-054	2.69
700-0NF1-054	2.84	701-0DT4-054	2.31	702-0D71-650	2.55	707-0WK4-054	2.69
700-0NF2-054	2.84	701-0E32-650	2.37	702-0D75-650	2.55	707-0WL0-054	2.69
700-0NF3-054	2.84	701-0E52-650	2.35	702-0D77-650	2.55	707-0WL1-054	2.69
700-0NF4-054	2.84	701-0E54-650	2.35	702-0D81-650	2.59	707-0WL4-054	2.69
701-0A96-650	2.43	701-0E58-650	2.35	702-0D83-650	2.59	707-0XK0-054	2.67
701-0A98-650	2.43	701-0E60-650	2.35	702-0D87-650	2.59	707-0XK1-054	2.67
701-0AS0-054	2.29	701-0E64-650	2.35	702-0D89-650	2.59	707-0XK4-054	2.67
701-0AS1-054	2.29	701-0E66-650	2.35	702-0D97-650	2.59	707-0XLO-054	2.67
701-0AS4-054	2.29	701-0UT0-054	2.45	702-0DL0-054	2.53	707-0XL1-054	2.67
701-0AT0-054	2.29	701-0UT1-054	2.45	702-0DL1-054	2.53	707-0XL4-054	2.67
701-0AT1-054	2.29	701-0UT4-054	2.45	702-0DL4-054	2.53	707-0YK0-054	2.67
701-0AT4-054	2.29	701-0US0-054	2.45	702-0E18-650	2.59	707-0YK1-054	2.67
701-0B08-650	2.39	701-0US1-054	2.45	702-0E51-650	2.57	707-0YK4-054	2.67
701-0B10-650	2.39	701-0US4-054	2.45	702-0E53-650	2.57	707-0YLO-054	2.67
701-0BS0-054	2.29	701-0W59-650	2.41	702-0E57-650	2.57	707-0YL1-054	2.67
701-0BS1-054	2.29	701-0W60-650	2.41	702-0E59-650	2.57	707-0YL4-054	2.67
701-0BS4-054	2.29	701-0W62-650	2.41	702-0E63-650	2.57	707-0ZK0-054	2.69
701-0BT0-054	2.29	701-0W63-650	2.41	702-0E65-650	2.57	707-0ZK1-054	2.69
701-0BT1-054	2.29	701-0W65-650	2.41	702-0EK0-054	2.75	707-0ZK4-054	2.69
701-0BT4-054	2.29	701-0W66-650	2.41	702-0EK1-054	2.75	707-0ZLO-054	2.69
701-0C54-650	2.39	702-0A95-650	2.63	702-0EK4-054	2.75	707-0ZL1-054	2.69
701-0C56-650	2.39	702-0A97-650	2.63	702-0ELO-054	2.75	707-0ZL4-054	2.69
701-0C78-650	2.39	702-0AK0-054	2.51	702-0EL1-054	2.75	708-0WS0-054	2.49
701-0C80-650	2.39	702-0AK1-054	2.51	702-0EL4-054	2.75	708-0WS1-054	2.49
701-0CS0-054	2.31	702-0AK4-054	2.51	702-0FK0-054	2.77	708-0WS4-054	2.49
701-0CS1-054	2.31	702-0AL0-054	2.51	702-0FK1-054	2.77	708-0WT0-054	2.49
701-0CS4-054	2.31	702-0AL1-054	2.51	702-0FK4-054	2.77	708-0WT1-054	2.49
701-0CT0-054	2.31	702-0AL4-054	2.51	702-0FLO-054	2.77	708-0WT4-054	2.49
701-0CT1-054	2.31	702-0B07-650	2.61	702-0FL1-054	2.77	708-0XS0-054	2.47
701-0CT4-054	2.31	702-0B09-650	2.61	702-0FL4-054	2.77	708-0XS1-054	2.47
701-0D30-650	2.43	702-0BLO-054	2.51	702-0GK0-054	2.77	708-0XS4-054	2.47
701-0D32-650	2.43	702-0BL1-054	2.51	702-0GK1-054	2.77	708-0XT0-054	2.47
701-0D36-650	2.43	702-0BL4-054	2.51	702-0GK4-054	2.77	708-0XT1-054	2.47
701-0D38-650	2.43	702-0BK0-054	2.51	702-0GL0-054	2.77	708-0XT4-054	2.47

Index

Item number	Page
708-0YT0-054	2.47
708-0YT1-054	2.47
708-0YT4-054	2.47
708-0YS0-054	2.47
708-0YS1-0 54	2.47
708-0YS4-054	2.47
708-0ZS0-054	2.49
708-0ZS1-054	2.49
708-0ZS4-054	2.49
708-0ZT0-054	2.49
708-0ZT1-054	2.49
708-0ZT4-054	2.49
721-0PK0-650	2.79
721-0PK4-650	2.79
721-0PLO-650	2.79
721-0PL4-650	2.79
728-1283	2.177
728-1284	2.177
728-1286	2.177
728-1287	2.177
728-4669	2.175
729-0K71-054	2.189
915-0320	2.199
915-0781-050	2.119
915-0896-050	2.119
915-4175	2.199
915-4183	2.199
915-7159-050	2.199
915-7185	2.201
915-7186	2.203
915-7188	2.203
915-7187	2.201
915-7190-050	2.199
915-7192	2.201
915-7193	2.203
915-7196-050	2.199
915-7199-050	2.199
915-0D22	2.199
915-0D22-381-K1	2.199
915-0D22-381-K2	2.199
915-0X59	2.199
915-0X59-381-K1	2.199
915-0X59-381-K2	2.199
915-0Z98-050	2.119
915-0Z99-050	2.119
926-0A26-050	2.165
926-0A27-050	2.165
950-0464-050	2.157
950-0465-050	2.157
950-0466-050	2.157
950-0T26-050	2.155
950-0T27-050	2.117
950-0T49-050	2.155

Item number	Page
950-0T50-050	2.117
950-0T51-050	2.155
950-0T52-050	2.117
951-0D45-054	2.189
951-0F15-650	2.191
972-0420	2.193
972-4564	2.193
972-4565	2.193
972-4566	2.193
972-0X19	2.195
972-0X34	2.195
973-0M99	4.27
973-0X35	4.23
973-0X39	4.25
973-4125	4.25
973-4126	4.25
973-4451	4.23, 4.27
973-9018	4.31
973-9060	4.29
974-4747	4.22
974-4748	4.22
974-4752	4.21
974-4753	4.22
974-4757	4.21
975-9216-040	4.7
975-9217-040	4.7
975-9218-040	4.7
975-9271-380	4.13
975-9272-380	4.13
975-9315-380	4.17
975-9317-380	4.17
975-9321-380	4.17
975-9333-380	4.15
975-9341-380	4.15
975-9342-380	4.15
975-9347-380	4.15
975-9373-040	4.19
975-9374-040	4.19
975-9375-040	4.19
975-9376-380	4.19
975-9377-380	4.19
975-9436-040	4.11
975-9437-040	4.11
975-9440-040	4.11
975-9442-040	4.11
975-9443-040	4.11
975-9456-380	4.9
975-9457-380	4.9
975-9459-380	4.9
975-9461-380	4.9
975-9462-380	4.9
975-9483-380	4.17
975-9492-380	4.13

Your authorized dealer