

System 5

Cams and Dowels

Quickfit TL Dowels

- Available in Ø5mm and Ø8mm for panel-to-panel applications
- Suitable for use with all Ø15mm Cam2000, Cam3000, Cam3000 S and Cam5000 products
- 'Klix' locking feature provides a strong, vibration proof joint
- Highly tolerant in edge-inserted, TL4 also in face-inserted applications

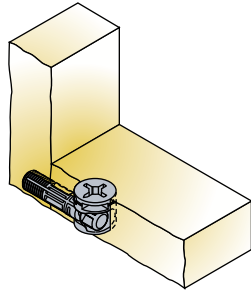

Technical and mounting details

Quickfit TL2

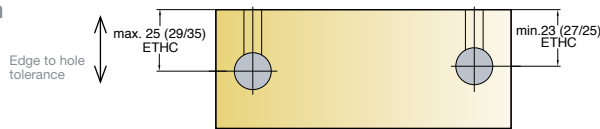
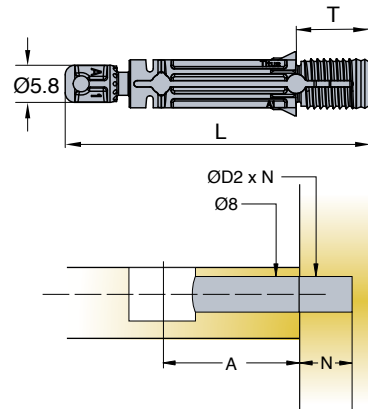

Tolerance range

2000 Pcs
1000 Pcs (05474)

Made of zinc, plastic

Quickfit TL4

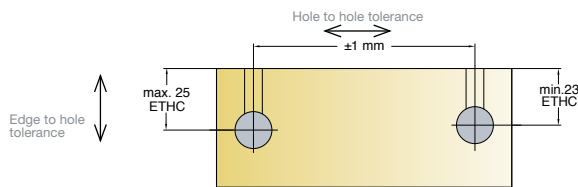
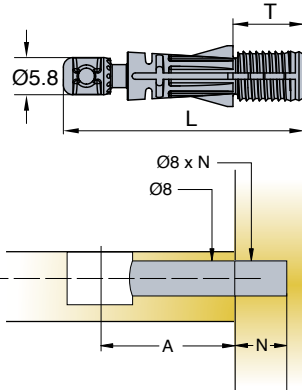

Tolerance range

3000 Pcs

Made of zinc, plastic

A	N	T	D2	Item number	Black	Dark grey
Drilling distance	Drilling depth	Thread length	Drilling diameter for dowel thread			
24	12	11.5	5	05453 →		880
34	12	11.5	5	05503 →		880
24	12	11.2	8	05366 →		880
28	12	11.2	8	05314 →		880
34	12	11.2	8	05474 →		880
24	12	11.2	8	05388 →	835	